



STANDARD OPERATING PROCEDURES

SOP: 2013
PAGE: 1 of 14
REV: 0.0
DATE: 02/15/02

SURFACE WATER SAMPLING

CONTENTS

- 1.0 SCOPE AND APPLICATION
- 2.0 METHOD SUMMARY*
- 3.0 SAMPLE PRESERVATION, CONTAINERS, HANDLING, AND STORAGE
- 4.0 INTERFERENCES AND POTENTIAL PROBLEMS
- 5.0 EQUIPMENT/APPARATUS*
- 6.0 REAGENTS
- 7.0 PROCEDURES
 - 7.1 Preparation
 - 7.2 Representative Sampling Considerations
 - 7.2.1 Sampler Composition
 - 7.3 Sample Collection
 - 7.3.1 Kemmerer Bottle*
 - 7.3.2 Van Doren Sampler*
 - 7.3.3 Bacon Bomb Sampler*
 - 7.3.4 Dip Sampler
 - 7.3.5 Direct Method
- 8.0 CALCULATIONS
- 9.0 QUALITY ASSURANCE/QUALITY CONTROL*
- 10.0 DATA VALIDATION
- 11.0 HEALTH AND SAFETY
- 12.0 REFERENCES*



STANDARD OPERATING PROCEDURES

SOP: 2013
PAGE: 2 of 14
REV: 0.0
DATE: 02/15/02

SURFACE WATER SAMPLING

CONTENTS (cont)

13.0 APPENDICES*

A - Figures*

* These sections affected by Revision 0.0.

SUPERSEDES: SOP #2013; Revision 0.0; 11/17/94; U.S. EPA Contract EP-W-09-031.



STANDARD OPERATING PROCEDURES

SOP: 2013
PAGE: 3 of 14
REV: 0.0
DATE: 02/15/02

SURFACE WATER SAMPLING

1.0 SCOPE AND APPLICATION

This standard operating procedure (SOP) is applicable to the collection of representative surface water samples from streams, rivers, lakes, ponds, lagoons, and surface impoundments. It includes samples collected from depth, as well as samples collected from the surface.

These are standard (i.e., typically applicable) operating procedures which may be varied or changed as required, dependent upon site conditions, equipment limitations or limitations imposed by the procedure. In all instances, the ultimate procedures employed should be documented and associated with the final report.

Mention of trade names or commercial products does not constitute United States Environmental Protection Agency (U.S. EPA) endorsement or recommendation for use.

2.0 METHOD SUMMARY

Sampling situations vary widely; therefore, no universal sampling procedure can be recommended. However, surface water sampling is generally accomplished through the use of one of the following samplers or techniques:

- Kemmerer bottle
- Van Doren sampler
- Bacon bomb sampler
- Dip sampler
- Direct method

These samplers and sampling techniques will result in the collection of representative samples from the majority of surface waters and impoundments encountered.

3.0 SAMPLE PRESERVATION, CONTAINERS, HANDLING, AND STORAGE

Once samples have been collected, the following procedures should be followed:

1. Transfer the sample(s) into suitable, labeled sample containers specific for the analyses to be performed.
2. Preserve the sample, if appropriate, or use pre-preserved sample bottles. Do not overfill bottles if they are pre-preserved.
3. Cap the container securely, place in a resealable plastic bag, and cool to 4°C.
4. Record all pertinent data in the site logbook and/or on field data sheets.
5. Complete the Chain of Custody record.
6. Attach custody seals to cooler prior to shipment.



STANDARD OPERATING PROCEDURES

SOP: 2013
PAGE: 4 of 14
REV: 0.0
DATE: 02/15/02

SURFACE WATER SAMPLING

7. Decontaminate all non-dedicated sampling equipment prior to the collection of additional samples.

4.0 INTERFERENCES AND POTENTIAL PROBLEMS

There are two primary interferences or potential problems associated with surface water sampling. These include cross contamination of samples and improper sample collection.

1. Cross contamination problems can be eliminated or minimized through the use of dedicated or disposable sampling equipment. If this is not possible or practical, then decontamination of sampling equipment is necessary. Refer to ERT/SERAS SOP #2006, *Sampling Equipment Decontamination*.
2. Improper sample collection can involve using contaminated equipment, disturbance of the stream or impoundment substrate, and sampling in an obviously disturbed or non-representative area.

Following proper decontamination procedures, minimizing disturbance of the sample site, and careful selection of sampling locations will eliminate these problems. Proper timing for the collection of samples must be taken into consideration due to tidal influences and low or fast-flowing streams or rivers.

5.0 EQUIPMENT/APPARATUS

Equipment needed for collection of surface water samples may include (depending on technique chosen):

- Kemmerer bottles
- Van Doren sampler
- Bacon bomb sampler
- Dip sampler
- Line and messengers
- Peristaltic pump
- Tygon tubing
- 0.45 micron (μm) filters
- Sample bottles/preservatives
- pH paper
- Resealable plastic bags
- Ice
- Coolers, packing material
- Chain of Custody records, custody seals
- Field data sheets
- Decontamination equipment/supplies
- Maps/plot plan
- Safety equipment
- Compass
- Tape measure
- Survey stakes, flags, or buoys and anchors
- Camera and film



STANDARD OPERATING PROCEDURES

SOP: 2013
PAGE: 5 of 14
REV: 0.0
DATE: 02/15/02

SURFACE WATER SAMPLING

- Logbook/waterproof pen
- Sample bottle labels
- Paper towels
- Disposable pipets
- Hydrolab

6.0 REAGENTS

Reagents will be utilized for preservation of samples and for decontamination of sampling equipment. The preservatives required are specified by the analysis to be performed and are summarized in ERT/SERAS SOP #2003, *Sample Storage, Preservation and Handling*. Decontamination solutions are specified in ERT/SERAS SOP #2006, *Sampling Equipment Decontamination*.

7.0 PROCEDURES

7.1 Preparation

1. Determine the extent of the sampling effort, the sampling methods to be employed, and the types and amounts of equipment and supplies needed.
2. Obtain the necessary sampling and monitoring equipment.
3. Decontaminate or pre-clean equipment, and ensure that it is in working order.
4. Prepare scheduling and coordinate with staff, clients, and regulatory agency, if appropriate.
5. Perform a general site survey prior to site entry, in accordance with the site specific Health and Safety Plan (HASP).
6. Use stakes, flags, or buoys to identify and mark all sampling locations. If required, the proposed locations may be adjusted based on site access, property boundaries, and obstructions.

7.2 Representative Sampling Considerations

In order to collect a representative sample, the hydrology and morphometrics of a stream, river, pond, lake or impoundment should be determined prior to sampling. This will aid in determining the presence of phases or layers in lagoons or impoundments, flow patterns in streams, and appropriate sample locations and depths.

Water quality data should be collected in ponds, lakes and impoundments to determine if stratification is present. Measurements of dissolved oxygen, pH, conductivity, oxidation-potential, temperature and turbidity can indicate if strata exist that would affect analytical results. Measurements should be collected at one-meter intervals from the surface to the bottom using the appropriate instrument (i.e., a Hydrolab or equivalent). These water quality measurements can assist in the interpretation of analytical data, and the selection of sampling sites and depths when



STANDARD OPERATING PROCEDURES

SOP: 2013
PAGE: 6 of 14
REV: 0.0
DATE: 02/15/02

SURFACE WATER SAMPLING

surface water samples are collected.

Factors that contribute to the selection of a sampling device used for sampling surface waters in streams, rivers, lakes, ponds, lagoons, and surface impoundments are:

- Width, depth, flow and accessibility of the location being sampled
- Whether the sample will be collected onshore or offshore

7.2.1 Sampler Composition

The appropriate sampling device must be of a proper composition. Selection of samplers constructed of glass, stainless steel, polyvinyl chloride (PVC) or PFTE (Teflon) should be based upon the suspected contaminants and the analyses to be performed.

7.3 Sample Collection

7.3.1 Kemmerer Bottle

A Kemmerer bottle (Figure 1, Appendix A) may be used in most situations where site access is from a boat or structure, such as a bridge or pier, and where samples at specific depths are required. Sampling procedures are as follows:

1. Use a properly decontaminated Kemmerer bottle. Set the sampling device so that the upper and lower stoppers are pulled away from the body, allowing the surface water to enter tube.
2. Lower the pre-set sampling device to the predetermined depth. Avoid disturbance of the bottom.
3. When the Kemmerer bottle is at the required depth, send the weighted messenger down the suspension line, closing the sampling device.
4. Retrieve the sampler and discharge the first 10-20 milliliters (mL) from the drain to clear potential contamination from the valve. This procedure may be repeated if additional sample volume is needed to fulfill analytical requirements. Subsequent grabs may be composited or transferred directly to appropriate sample containers.

7.3.2 Van Doren Sampler

A Van Doren sampler (Figure 2, Appendix A) is used to collect surface water from a very specific sampling depth or from a shallow water body. Since the sampler is suspended horizontally, the depth interval sampled is the diameter of the sampling tube. The sampling procedure is as follows:

1. Use a properly decontaminated Van Doren sampler. Set the device so that the end stoppers are pulled away from the body allowing surface water to enter the



STANDARD OPERATING PROCEDURES

SOP: 2013
PAGE: 7 of 14
REV: 0.0
DATE: 02/15/02

SURFACE WATER SAMPLING

tube.

2. Lower the pre-set sampling device to the predetermined depth. Avoid disturbance of the bottom.
3. When the Van Doren is at the required depth, send the weighted messenger down the suspension line, closing the sampling device.
4. Retrieve the sampler and discharge the first 10-20 milliliters (mL) from the drain to clear potential contamination from the valve. This procedure may be repeated if additional sample volume is needed to fulfill analytical requirements. Subsequent grabs may be composited or transferred directly to appropriate sample containers.

7.3.3 Bacon Bomb Sampler

A bacon bomb sampler (Figure 3, Appendix A) may be used in situations similar to those outlined for the Kemmerer bottle. Sampling procedures are as follows:

1. Lower the bacon bomb sampler carefully to the desired depth, allowing the line for the trigger to remain slack at all times. When the desired depth is reached, pull the trigger line until taut. This will allow the sampler to fill.
2. Release the trigger line and retrieve the sampler.
3. Discharge the first 10-20 milliliters (mL) from the drain to clear potential contamination from the valve. This procedure may be repeated if additional sample volume is needed to fulfill analytical requirements. Subsequent grabs may be composited or transferred directly to appropriate sample containers.

7.3.4 Dip Sampler

A dip sampler (Figure 4, Appendix A) is useful in situations where a sample is to be recovered from an outfall pipe or along a lagoon bank where direct access is limited. The long handle on such a device allows access from a discrete location. Sampling procedures are as follows:

1. Assemble the device in accordance with the manufacturer's instructions.
2. Extend the device to the sample location and collect the sample by dipping the sampler into the water.
3. Retrieve the sampler and transfer the sample to the appropriate sample container(s).

7.3.5 Direct Method



STANDARD OPERATING PROCEDURES

SOP: 2013
PAGE: 8 of 14
REV: 0.0
DATE: 02/15/02

SURFACE WATER SAMPLING

For streams, rivers, lakes, and other surface waters, the direct method may be utilized to collect water samples directly into the sample container(s). Health and safety considerations must be addressed when sampling lagoons or other impoundments where specific conditions may exist that warrant the use of additional safety equipment. These issues must be addressed in the site-specific HASP.

Using adequate protective clothing, access the sampling station by appropriate means. For shallow stream stations, collect the sample under the water surface while pointing the sample container upstream; the container must be upstream of the collector. Avoid disturbing the substrate. For lakes and other impoundments, collect the sample under the water surface while avoiding surface debris and the boat wake.

When using the direct method, do not use pre-preserved sample bottles as the collection method may dilute the concentration of preservative necessary for proper sample preservation.

8.0 CALCULATIONS

This section is not applicable to this SOP.

9.0 QUALITY ASSURANCE/QUALITY CONTROL

There are no specific quality assurance (QA) activities which apply to the implementation of these procedures. However, the following general QA procedures apply:

1. All data must be documented on field data sheets or within site logbooks.
2. All instrumentation must be operated in accordance with operating instructions as supplied by the manufacturer, unless otherwise specified in the work plan. Equipment checkout and calibration activities must occur prior to sampling/operation and they must be documented.
3. To avoid the incidental inclusion of disturbed sediment in the sample, surface water should be collected from a downstream to upstream direction and upstream of any activity that may disturb the sediment (i.e., wading).
4. While collecting surface water using the direct method, the sample container should be held below the surface to avoid the collection of floating debris.
5. Water quality data should be collected to detect the presence of stratified layers or other site-specific characteristics that would affect the sample.

10.0 DATA VALIDATION

This section is not applicable to this SOP.

11.0 HEALTH AND SAFETY



STANDARD OPERATING PROCEDURES

SOP: 2013
PAGE: 9 of 14
REV: 0.0
DATE: 02/15/02

SURFACE WATER SAMPLING

When working with potentially hazardous materials, follow U.S. EPA, Occupational Health and Safety (OSHA) and corporate health and safety procedures.

More specifically, when sampling lagoons or surface impoundments containing known or suspected hazardous substances, adequate health and safety and boating precautions must be taken to ensure the safety of sampling personnel.

12.0 REFERENCES

Wilde, F.D., D.B. Radtke, J. Gibs and R.T. Iwatsubo. 1998. National Field Manual for the Collection of Water-Quality Data - Selection of Equipment for Water Sampling. U.S. Geological Survey Techniques of Water - Resources Investigations, Book 9, Chap. A2, variously paged.

<http://water.usgs.gov/owq/FieldManual/index.html> and
<http://water.usgs.gov/owq/FieldManual/mastererrat.html>

U.S. Environmental Protection Agency. 1984. Characterization of Hazardous Waste Sites - A Methods Manual: Volume II. Available Sampling Methods, Second Edition. EPA/600/4-84-076.

13.0 APPENDICES

A - Figures



STANDARD OPERATING PROCEDURES

SOP: 2013
PAGE: 10 of 14
REV: 0.0
DATE: 02/15/02

SURFACE WATER SAMPLING

APPENDIX A
Figures
SOP #2013
February 2002



STANDARD OPERATING PROCEDURES

SOP: 2013
PAGE: 11 of 14
REV: 0.0
DATE: 02/15/02

SURFACE WATER SAMPLING

FIGURE 1. Kemmerer Bottle

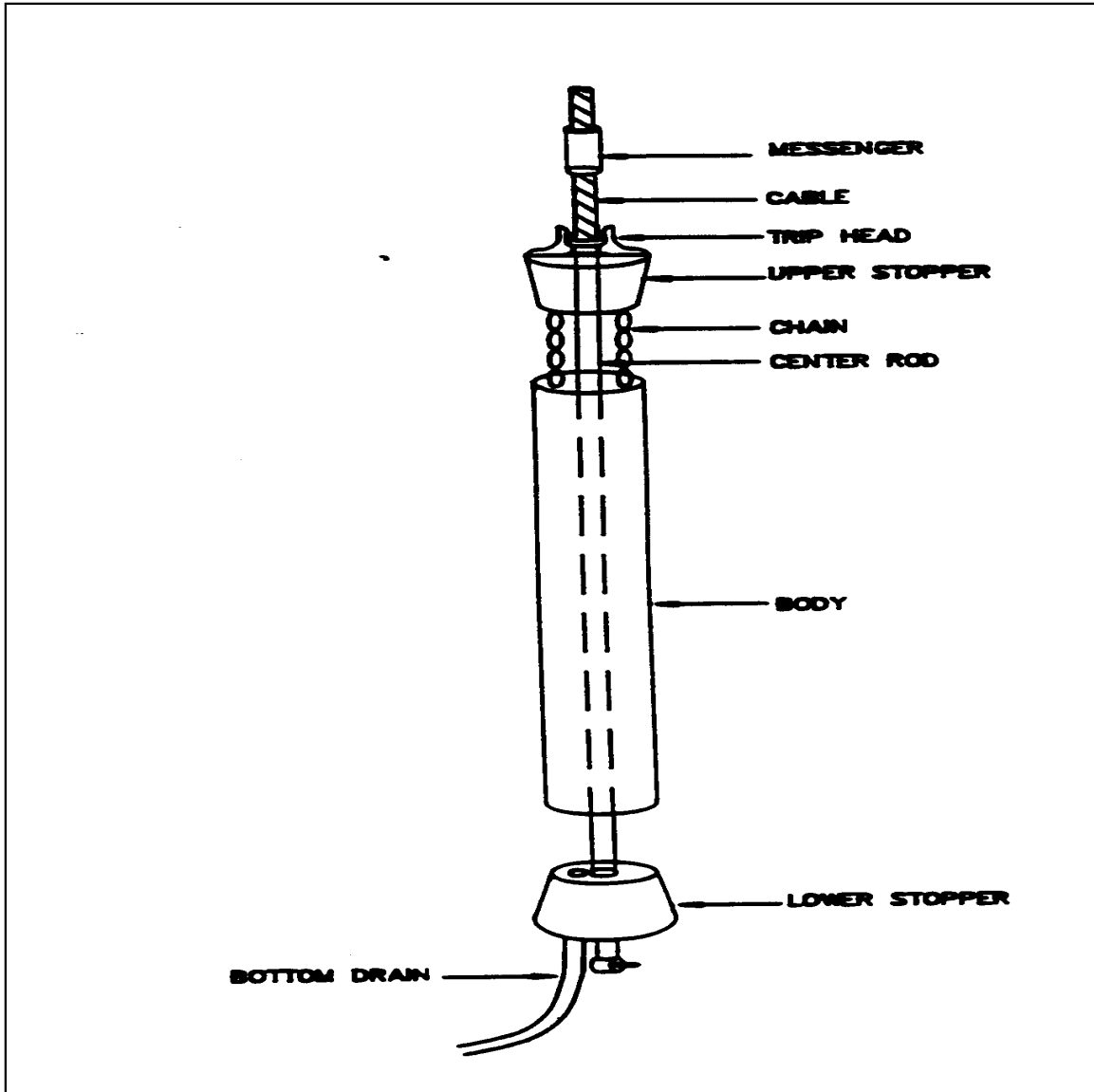



STANDARD OPERATING PROCEDURES

SOP: 2013
PAGE: 12 of 14
REV: 0.0
DATE: 02/15/02

SURFACE WATER SAMPLING

FIGURE 2. Van Doren Sampler

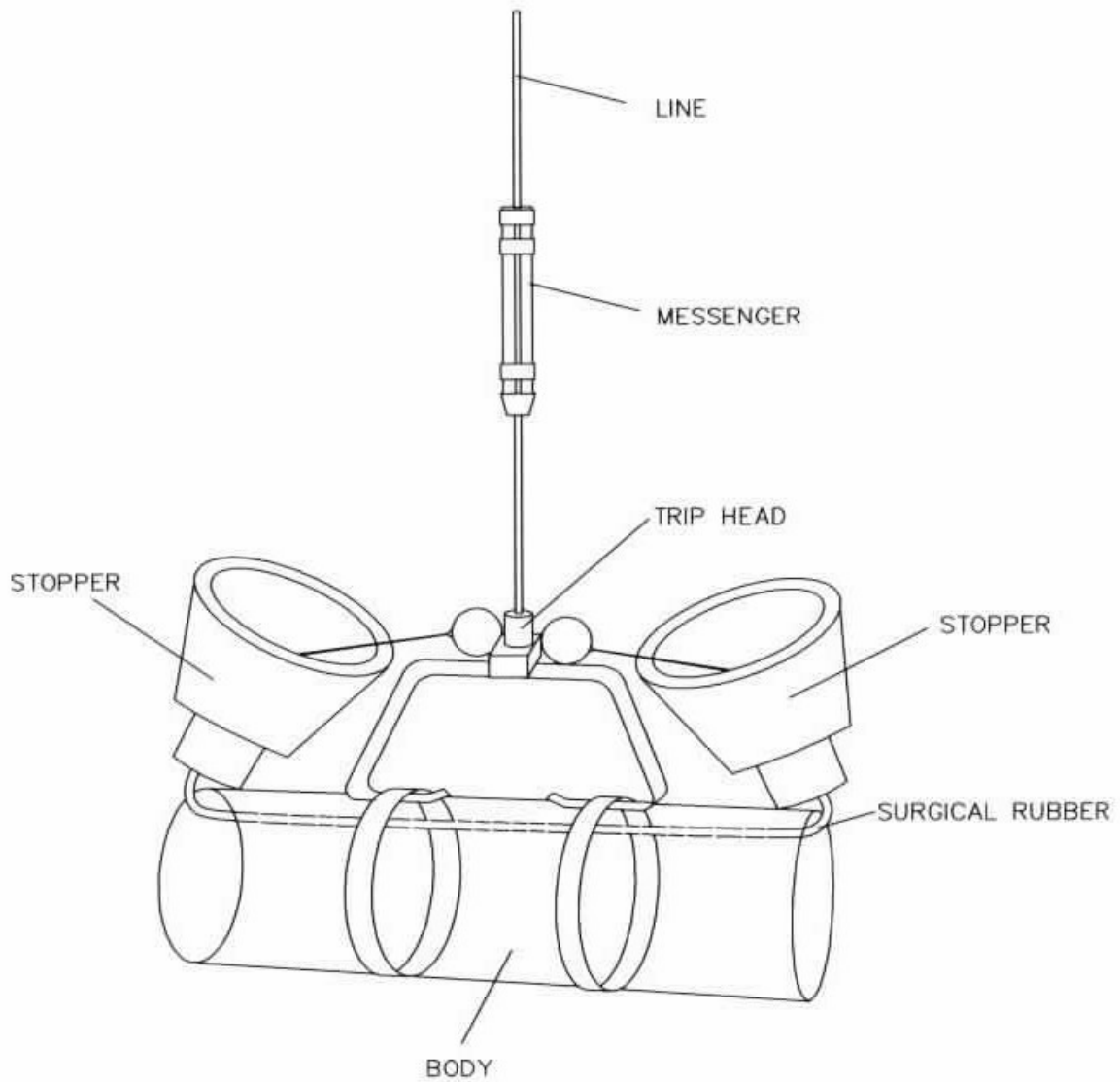



STANDARD OPERATING PROCEDURES

SOP: 2013
PAGE: 13 of 14
REV: 0.0
DATE: 02/15/02

SURFACE WATER SAMPLING

FIGURE 3. Bacon Bomb Sampler

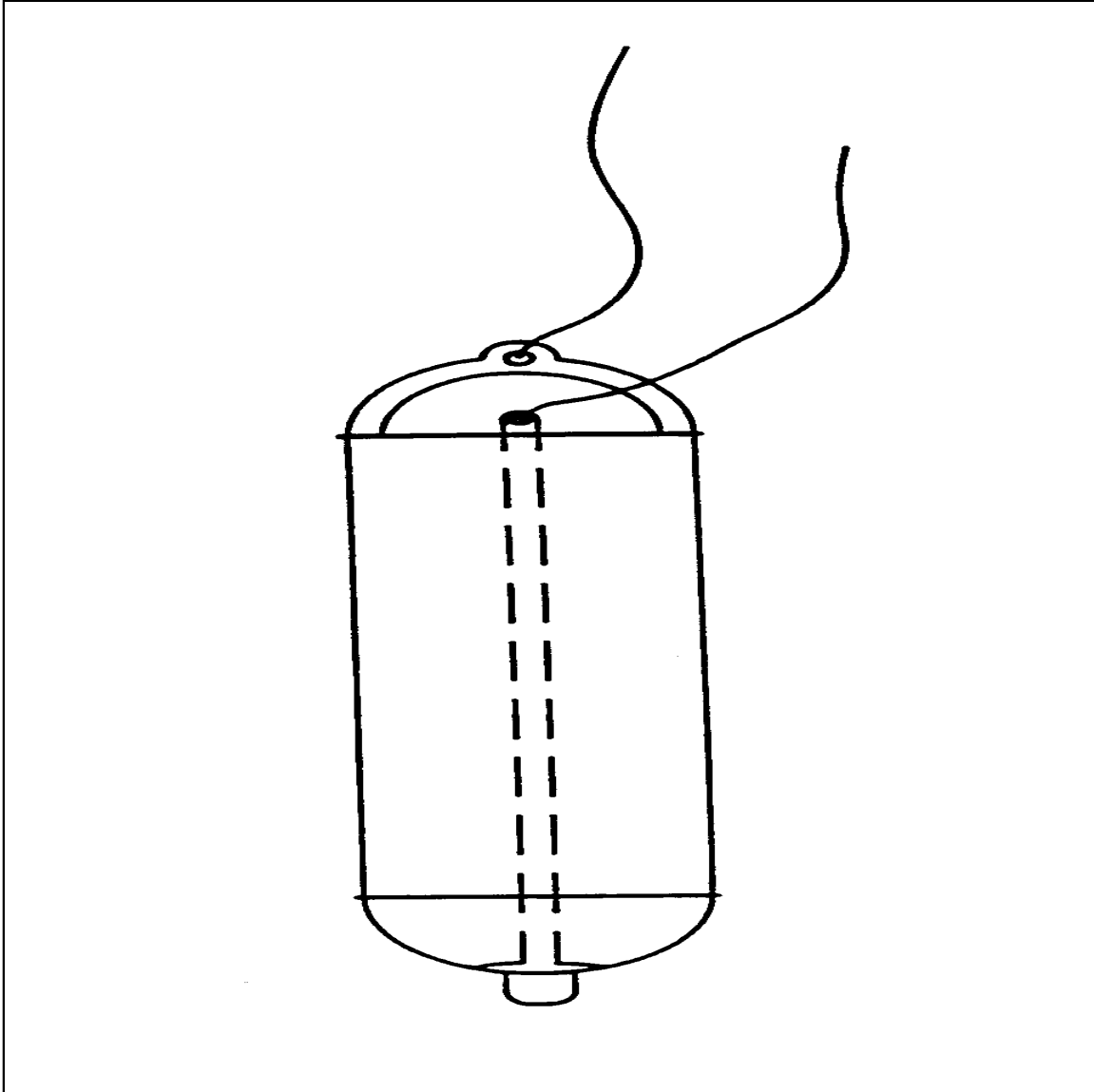



STANDARD OPERATING PROCEDURES

SOP: 2013
PAGE: 14 of 14
REV: 0.0
DATE: 02/15/02

SURFACE WATER SAMPLING

FIGURE 4. Dip Sampler

