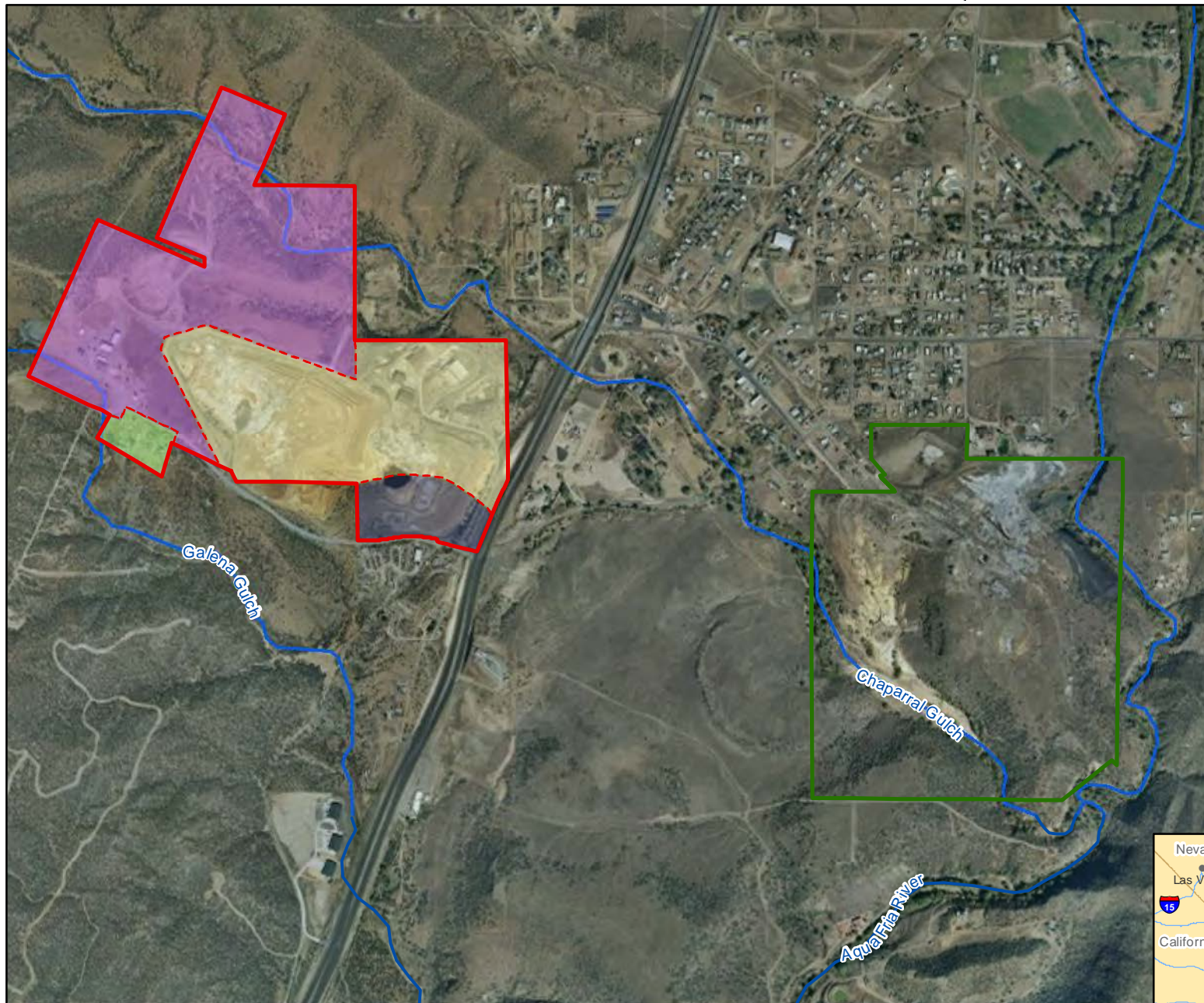



Figure 1
Site Location Map

Iron King Mine - Humboldt Smelter Removal Site
Dewey-Humboldt, Yavapai County, Arizona





Legend

-  **Iron King Mine**
-  Iron King Mine Proper Area
-  Iron King Operations Center
-  Former Fertilizer Plant Area
-  Salvage Yard
-  **Humboldt Smelter**

 **Waterways**
Chaparral Gulch, Galena Gulch, Agua Fria River

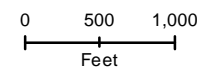

Source:
Aerial Photo: ESRI World Imagery
EA Remedial Investigation Report,
Revision 01, March 2010



**Figure 2
Site Map**

**Iron King Mine - Humboldt Smelter Removal Site
Dewey-Humboldt, Yavapai County, Arizona**

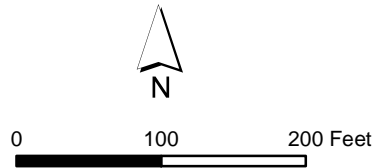
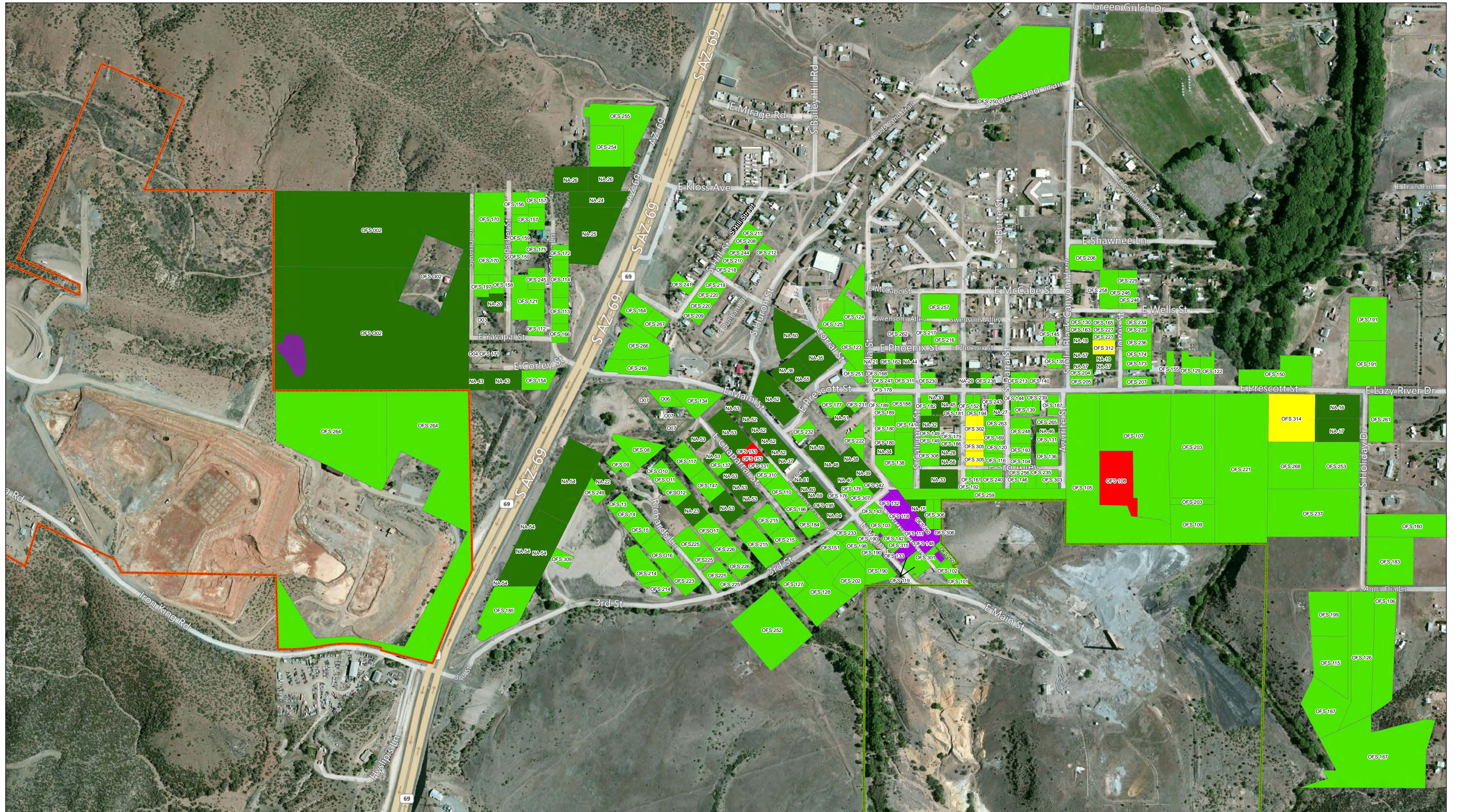

Figure 3
Former Small Tailings Pile
Iron King Mine - Humboldt Smelter Removal
Dewey-Humboldt, Yavapai County, AZ



Visually Assessed; No Current Removal Program Action Recommended	Additional Removal Assessment Sampling Recommended; Unable to Obtain Access	Yellow: Potential Candidate for Removal Assessment; Unable to Obtain Access	Parcels
Previously Assessed and Data Reviewed; No Current Removal Program Action Recommended	Iron King Mine		
No Further Removal Action Recommended; Removal Action Performed in 2006	Humboldt Smelter		
Removal Conducted			

Note: Recommendations based on START's understanding of criteria for time critical removal actions and do not necessarily indicate that soil concentrations for lead and arsenic are less than USEPA Region 9 Regional Screening Levels (RSLs) and/or ADEQ's Soil Screening Levels (SSLs)

0 200 400 800 Feet

Figure 4
In-Town Parcel Assessment and Removal
Iron King Mine - Humboldt Smelter Removal
Yavapai County, Arizona

Ecology and Environment, Inc.
Environmental Stewardship in the Environment



LEGEND

 Footprint



0 200 400 Feet

A horizontal scale bar with markings at 0, 200, and 400 feet.

Figure 5
Footprint of Removed Soil Placed on
Iron King Mine Main Tailings Pile
Iron King Mine - Humboldt Smelter Removal
Yavapai County, Arizona



LEGEND

 Removal Area



0 50 100 Feet



Figure 6
OFS-103 Removal Area
Iron King Mine - Humboldt Smelter Removal
Yavapai County, Arizona



LEGEND

 Removal area

 Humboldt Smelter

1 = Confirmation Sample Identifier
(represents sample OFS-111-001)



0 50 100 Feet





Figure 7
OFS-111 Removal Areas
Iron King Mine - Humboldt Smelter Removal
Yavapai County, Arizona



LEGEND

 Removal area



0 50 100 Feet



1 = Confirmation Sample Identifier
(represents sample OFS-118-001)

Figure 8
OFS-118 Removal Areas
Iron King Mine - Humboldt Smelter Removal
Yavapai County, Arizona



LEGEND



Removal area

1

= Confirmation Sample Identifier
(represents sample OFS-132-001)





0 50 100 Feet



Figure 9
OFS-132 Removal Areas
Iron King Mine - Humboldt Smelter Removal
Yavapai County, Arizona



LEGEND

-  Removal area
-  Humboldt Smelter

1 = Confirmation Sample Identifier
(represents sample OFS-133-001)



0 50 100 Feet

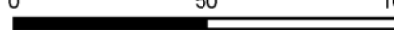



Figure 10
OFS-133 and OFS-119 Removal Areas
Iron King Mine - Humboldt Smelter Removal
Yavapai County, Arizona



LEGEND

-  Removal area
-  Humboldt Smelter

1 = Confirmation Sample Identifier
(represents sample OFS-148-001)



0 50 100 Feet



Figure 11
OFS-148 Removal Areas
Iron King Mine - Humboldt Smelter Removal
Yavapai County, Arizona



LEGEND

 Removal area



0 50 100 Feet

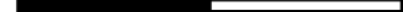
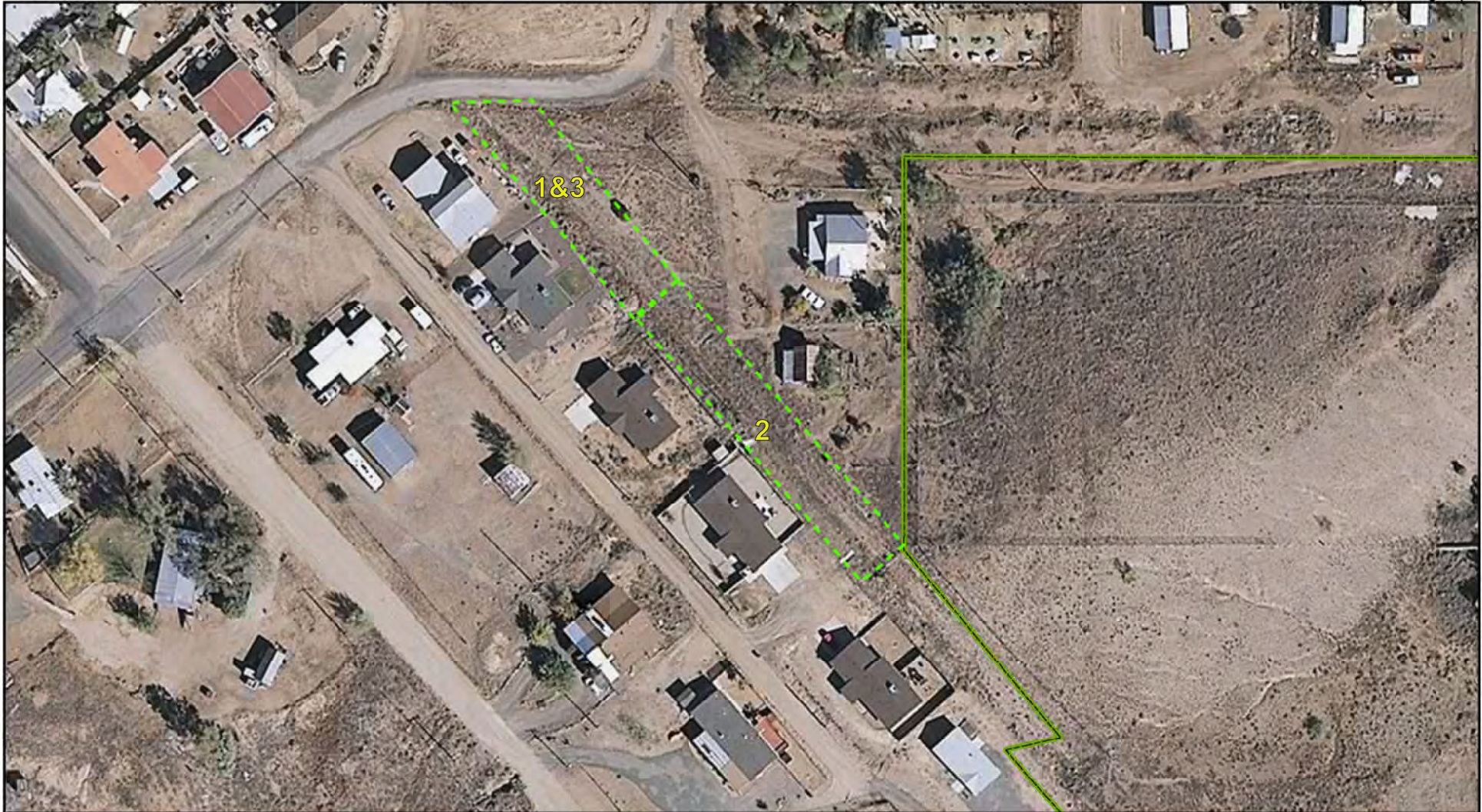

Figure 12
OFS-208 and OFS-244 Removal Area
Iron King Mine - Humboldt Smelter Removal
Yavapai County, Arizona



LEGEND



Removal area



Humboldt Smelter

2 = Confirmation Sample Identifier
(represents sample OFS-260-002)



N



0 100 200 Feet



Figure 13
OFS-260 Removal Areas
Iron King Mine - Humboldt Smelter Removal
Yavapai County, Arizona



LEGEND

-  Removal area
-  Humboldt Smelter
- 2** = Confirmation Sample Identifier
(represents sample OFS-301-002)

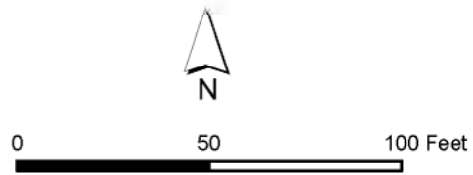

Figure 14
OFS-301 Removal Areas
Iron King Mine - Humboldt Smelter Removal
Yavapai County, Arizona



LEGEND



Removal Area



Humboldt Smelter

1

= Confirmation Sample Identifier
(represents sample OFS-306-001)

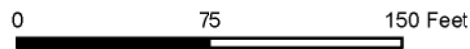

Figure 15
OFS-306 Removal Areas
Iron King Mine - Humboldt Smelter Removal
Yavapai County, Arizona

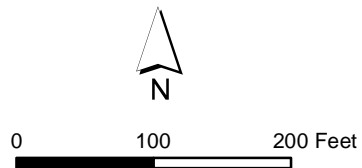

Figure 16
New Diversion Channel and
Location of Temporary Road
Iron King Mine - Humboldt Smelter Removal
Dewey-Humboldt, Yavapai County, AZ



- Applied October 1, 2011
- Applied October 9, 2011
- Applied October 27, 2011

Figure 18
Application of Fixative to Humboldt Smelter Ash
Iron King Mine - Humboldt Smelter Removal
Yavapai County, Arizona

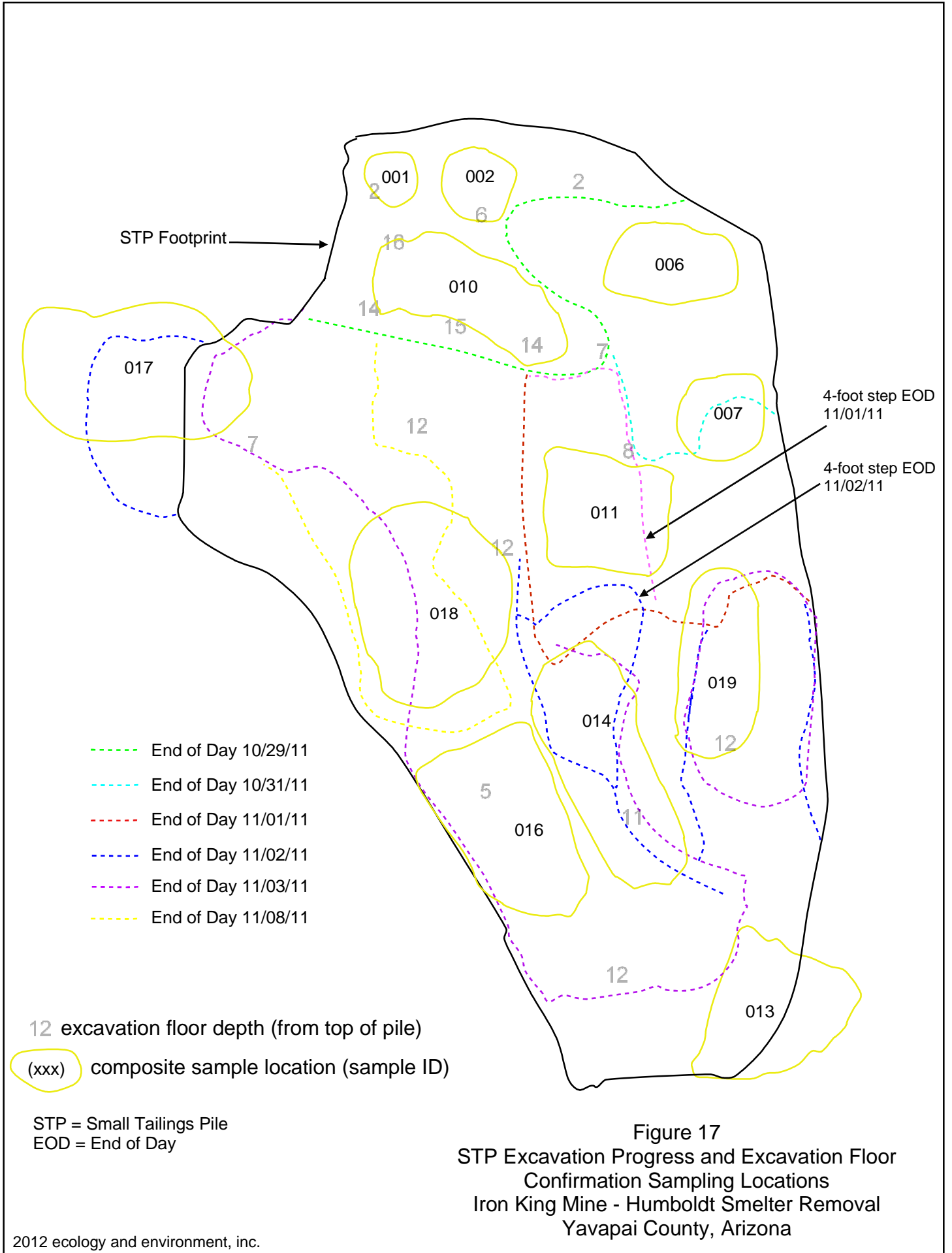

Table 1
Properties Subject to U.S. EPA Time-Critical Removal Action
Dewey-Humboldt, Arizona

TDD No. 02-09-11-08-0005

Project No. 002693.2155.01RF

	Site ID	Parcel No.	Physical Address	Mailing Address	Acres
Complete Removal	OFS 111	402-06-102L	2925 South Sweet Pea Lane	PO Box 485 Humboldt, AZ 86329	0.27
	OFS 118	402-06-102K	2905 South Sweet Pea Lane	PO Box 508 Humboldt, AZ 86329	0.27
	OFS 132	402-06-102P	2875 South Third Street	PO Box 122 Humboldt, AZ 86329	0.25
	OFS 260	800-27-005T	Unsurfaced right-of-way behind Sweet Pea Lane	Municipal property	0.5 (approx.)
	OFS 148	402-06-102M	2945 Sweet Pea Lane	1575 Purple Sage Road Chino Valley, AZ 86323	0.27
	OFS 133 OFS-119 (NE corner of OFS-119 added to removal at OFS-133)	402-07-006	13070 Main Street	PO Box 338 Humboldt, AZ 86329	0.23
Hot-Spot Removal		402-07-007C	13080 East Main Street	PO Box 552 Humboldt, AZ 86329	0.48
	OFS-103	402-07-002B	13030 East Main Street	PO Box 488 Humboldt, AZ 86329	0.46
	OFS 208 OFS-244 (one hot spot between two parcels)	402-09-016D	2565 Hill Street	PO Box 32 Humboldt, AZ 86329	0.21
		402-09-016H	2575 Hill Street	PO Box 548 Humboldt, AZ 86329	0.21
	OFS-002 (hot spot is the STP)	402-08-034A	12470 East Yavapai Road	PO Box 721 Dewey, AZ 86327	0.6
	OFS-301	402-06-102N	2965 Sweet Pea Lane	PO Box 905 Humboldt, AZ 86329	0.28
	OFS-306	402-06-026	13087 E. Main Street	PO Box 699	0.19
402-06-027B		13089 E. Main Street	Humboldt, AZ 86329	0.32	

2012 ecology and environment, inc.

Table 2
Air Monitoring and Sampling Results
Iron King Mine - Humboldt Smelter Removal
(mg/m³)

TDD No. 02-09-11-08-0005

Project No. 002693.2155.01RF

Date	Dust Monitor ID	Location	Maximum Per-Minute Average*	Overall Average*	Maximum STEL*	Comment	Air Sample Result
9/13/2011	D269	Main Street at 3rd	N/A	0.005	N/A		
	D271	Main Street, near gate	N/A	0.005	N/A		
	1	Main Street at 3rd	0.006	0.000	0.002		
9/14/2011	1	North of OFS-148	0.095	0.012	0.022		As: ND; Pb: ND
	2	South of OFS-148	0.012	0.003	0.006		As: ND; Pb: ND
	3	West of OFS-148	0.067	0.005	0.024		As: ND; Pb: ND
9/15/2011	1	North of OFS-148	0.392	0.044	0.071		As: ND; Pb: ND
	2	South of OFS-148	0.106	0.009	0.041		As: ND; Pb: ND
	3	West of OFS-148	0.798	0.013	0.067		As: ND; Pb: ND
9/16/2011	1	North of OFS-111	0.659	0.029	0.095	Maximum coincided with air monitor being dropped during relocation	
	2	South of OFS-148	0.054	0.000	0.019		
	3	West of OFS-148	0.273	0.008	0.043		
9/17/2011	1	North of OFS-111	0.212	0.006	0.023		
	2	South of OFS-111	0.072	0.000	0.007		
	3	West of OFS-111	0.142	0.009	0.027		
9/19/2011	1	North of OFS-111	0.085	0.011	0.037		
	2	South of OFS-111	0.052	0.006	0.020		
	3	West of OFS-111	0.776	0.008	0.088		
9/20/2011	1	North of OFS-148	0.104	0.007	0.026		
	2	West of OFS-148	0.417	0.000	0.011		
	3	South of OFS-148	0.224	0.008	0.030		
9/21/2011	1	North of OFS-148	0.085	0.004	0.014		
	2	East of OFS-148	0.075	0.006	0.013		
	3	South of OFS-148	0.244	0.023	0.072		
9/22/2011	1	OFS-111	0.073	0.000	0.011		As: ND; Pb: ND
	2	OFS-301	0.130	0.020	0.035		As: ND; Pb: ND
	3	OFS-306	0.643	0.030	0.104		As: ND; Pb: ND
9/23/2011	1	OFS-118	0.254	0.023	0.049		
	2	OFS-301	0.464	0.012	0.059		
	3	West of OFS-111	0.756	0.031	0.134		
	4	OFS-306	0.043	0.005	0.009		
9/24/2011	1	OFS-118	0.238	0.017	0.044		
	2	OFS-301	0.317	0.015	0.086		
	3	OFS-111 Fence	0.176	0.027	0.044		
	4	Across 3rd Street/OFS-260	1.569	0.014	0.127		
9/26/2011	1	OFS-118 Swing Set	0.148	0.019	0.034		
	2	OFS-301	0.050	0.002	0.012		
	3	OFS-111 Fence/OFS-103	0.129	0.025	0.038		
	4	OFS-306	0.021	0.000	0.003		
9/27/2011	1	OFS-111 Back Porch	0.234	0.022	0.057		
	2	OFS-301 Table	0.309	0.014	0.082		
	3	OFS-103 Chair	0.136	0.000	0.019		
	4	OFS-132 Truck	0.201	0.010	0.036		
9/28/2011	1	OFS-111 Back Porch	1.567	0.009	0.214		
	2	OFS-301 Table	0.254	0.019	0.55		
	3	OFS-103 Chair	0.057	0.000	0.007		
	4	OFS-132 Truck	Data lost	0.002	0.016		
9/29/2011	1	OFS-306 Fence by Shed	0.143	0.006	0.035		
	2	OFS-111 Back Porch	0.280	0.007	0.032		
	3	Sweet Pea Lane Fence	0.393	0.003	0.053		
	4	OFS-132 Porch/ 2850 3rd Street	0.425	0.012	0.043		

Notes:

As - Arsenic

Pb - Lead

mg/m³ - Milligrams per cubic meter

N/A - Not applicable

ND - Not detected above laboratory detection limit

STEL - Short Term Exposure Limit (reported by the instrument)

STP - Small tailings pile

Table 2
Air Monitoring and Sampling Results
Iron King Mine - Humboldt Smelter Removal
(mg/m³)

TDD No. 02-09-11-08-0005

Project No. 002693.2155.01RF

Date	Dust Monitor ID	Location	Maximum Per-Minute Average*	Overall Average*	Maximum STEL*	Comment	Air Sample Result	
9/30/2011	1	OFS-118 near Swing Set	0.116	0.018	0.041			
	2	Sweet Pea Lane Fence by OFS-132	0.749	0.020	0.075			
	3	2850 3rd Street	0.589	0.030	0.155	Spike likely due to street sweeper		
10/1/2011	1	2850 3rd Street	0.160	0.000	0.019			
	2	Sweet Pea Lane Fence by OFS-132	0.085	0.036	0.046			
	3	Fence between OFS244/208	0.425	0.010	0.078			
10/3/2011	1	OFS-111 Back Porch	0.262	0.000	0.083			
	2	Sweet Pea Lane next to OFS-132	0.766	0.031	0.133	Spike likely caused by trash truck		
	3	2850 3rd St	0.227	0.009	0.034			
	4	OFS-244/208	0.194	0.013	0.056			
10/4/2011	1	OFS-111	0.457	0.045	0.164			
	2	OFS-118	0.448	0.035	0.105			
	3	OFS-132	0.424	0.029	0.081			
	4	EPA Command Post	1.843	0.042	0.042	Spike due to 40 mph wind gust blowing over porta-potty directly adjacent to air monitoring station		
10/5/2011	1	OFS-118	0.109	0.015	0.048			
	2	OFS-306	0.126	0.020	0.051			
	3	2850 3rd Street	0.575	0.151	0.054			
	4	OFS-103	0.083	0.009	0.021			
10/6/2011	1	OFS-118	0.117	0.009	0.036			
	2	OFS-306	0.588	0.007	0.058			
	3	2850 3rd Street	0.147	0.031	0.058			
	4	OFS-103	0.050	0.002	0.010			
10/7/2011	1	OFS-118	0.557	0.023	0.061			
	2	OFS-306	0.035	0.001	0.013			
	3	2850 3rd Street	0.953	0.016	0.094	Wind gusts		
	4	OFS-103	0.028	0.004	0.009			
10/8/2011	1	2850 3rd Street	0.060	0.000	0.005			
	2	OFS-119	0.099	0.004	0.022			
	3	OFS-306	0.067	0.019	0.030			
	4	OFS-118	0.123	0.005	0.022			
10/10/2011	1	2850 3rd Street	0.330	0.033	0.087		As: ND Pb: 0.000447	
	2	OFS-119	0.218	0.023	0.042		As: ND; Pb: ND	
	3	OFS-118	0.265	0.021	0.079		As: ND; Pb: ND	
	4	South of OFS-103 on Main Street	1.407	0.018	0.159	Located next to import material gate	As: ND; Pb: ND	
10/11/2011	1	2850 3rd Street	Monitoring Data Lost - Equipment Malfunction					
	2	OFS-119	0.719	0.064	0.180			
	3	OFS-118/SPL Fence	0.368	0.030	0.122			
	4	South of OFS-103 on Main Street	0.361	0.004	0.032			
10/12/2011	1	2850 3rd Street	1.307	0.011	0.136			
	2	OFS-119	0.310	0.040	0.078			
	3	OFS-119/SPL Fence	0.199	0.021	0.050			
10/13/2011	1	2850 3rd Street	0.330	0.005	0.045			
	2	OFS-119	0.510	0.038	0.156			
	3	OFS-119/Sweet Pea Lane Fence	0.284	0.040	0.080			

Notes:

As - Arsenic

Pb - Lead

mg/m³ - Milligrams per cubic meter

N/A - Not applicable

ND - Not detected above laboratory detection limit

STEL - Short Term Exposure Limit (reported by the instrument)

STP - Small tailings pile

Table 2
Air Monitoring and Sampling Results
Iron King Mine - Humboldt Smelter Removal
(mg/m³)

TDD No. 02-09-11-08-0005

Project No. 002693.2155.01RF

Date	Dust Monitor ID	Location	Maximum Per-Minute Average*	Overall Average*	Maximum STEL*	Comment	Air Sample Result
10/14/2011	1	OFS-119	0.258	0.022	0.095		
	2	2850 3rd Street	0.844	0.045	0.153		
	3	OFS-118/SPL fence	0.783	0.047	0.096		
10/24/2011	1	2850 3rd Street	1.542	0.011	0.141		
	2	OFS-119	0.205	0.039	0.059		
	3	OFS-306	0.248	0.030	0.056		
10/25/2011	1	OFS-119	0.254	0.000	0.020		
	2	2850 3rd Street	2.130	0.034	0.204		
	3	OFS-306	0.326	0.047	0.995		
10/26/2011	1	OFS-119	0.147	0.060	0.103		
	2	2850 3rd Street	0.077	0.024	0.042		
	3	OFS-103 Fence	0.061	0.037	0.041		
10/27/2011	1	STP North	0.195	0.117	0.154		
	2	STP South	0.046	0.018	0.022		
	3	STP East	0.079	0.027	0.037		
10/28/2011	1	STP North	0.384	0.168	0.345		
	2	STP South	0.090	0.021	0.031		
	3	STP East	0.171	0.027	0.044		
10/29/2011	1	STP North	0.178	0.047	0.144		
	2	STP South	0.038	0.019	0.028		
	3	STP East	0.222	0.025	0.040		
10/31/2011	1	STP North	0.470	0.115	0.315		As: ND; Pb: ND
	2	STP South	0.043	0.014	0.020		As: ND; Pb: ND
	3	STP East	0.181	0.029	0.058		As: ND; Pb: ND
11/1/2011	1	STP North	0.809	0.346	0.664		
	2	STP South	0.064	0.028	0.041		
	3	STP East	0.071	0.003	0.041		
11/2/2011	1	STP North	0.365	0.022	0.063		
	2	STP South	0.074	0.008	0.025		
	3	STP East	0.049	0.004	0.013		
11/3/2011	1	STP North	0.148	0.021	0.054		
	2	STP South	0.063	0.023	0.036		
	3	STP East	0.447	0.008	0.035		
11/4/2011	1	STP North	0.391	0.047	0.151		
	2	STP South	0.078	0.013	0.044		
	3	STP East	0.331	0.020	0.055		
11/6/2011	1	STP North	0.083	0.017	0.043		
	2	STP South	0.019	0.003	0.006		
	3	STP East	0.048	0.009	0.016		
11/8/2011	1	STP North	0.019	0.005	0.010		As: ND; Pb: ND
	2	STP South	0.042	0.001	0.009		As: ND; Pb: ND
	3	STP East	0.014	0.001	0.010		As: ND; Pb: ND
11/9/2011	1	STP North	0.025	0.000	0.012		
	2	STP South	0.023	0.004	0.006		
	3	STP East	0.035	0.003	0.01		
11/10/2011	1	STP North	0.076	0.011	0.025		
	2	STP South	0.044	0.004	0.008		
	3	STP East	0.046	0.002	0.010		
11/11/2011	1	STP North	0.104	0.012	0.028		
	2	STP South	0.070	0.008	0.019		
	3	STP East	0.112	0.010	0.029		
11/12/2011	1	STP North	0.119	0.011	0.031		
	2	STP South	0.097	0.002	0.014		
	3	STP East	0.047	0.007	0.023		

* - The site-specific action level is 2.5 mg/m³

2012 ecology and environment, inc.

Notes:

As - Arsenic

Pb - Lead

mg/m³ - Milligrams per cubic meter

N/A - Not applicable

ND - Not detected above laboratory detection limit

STEL - Short Term Exposure Limit (reported by the instrument)

STP - Small tailings pile

Table 3
Borrow Area Sample Results
Iron King Mine - Humboldt Smelter Removal
Results in milligrams per kilogram

TDD No. 02-09-11-08-0005

Project No. 002693.2155.01RF

Borrow Source Identifier	Sample Description	Date Collected	Analyte (Site-Specific Action Level)							
			Arsenic (38)	Lead (23)	Barium (5,300)	Cadmium (38)	Chromium (2,100)	Mercury (6.7)	Selenium (380)	Silver (380)
			MDI Prescott Valley	BA-1-1	8/31/2011	350	8.7	390	<0.50	120
	BA-1-2	210	<5.0	220		<0.50	110	<0.090	<5.0	<2.5
G&S Prescott Valley	BA-2-1	30	<5.0	37		<0.50	33	<0.10	<5.0	<2.5
	BA-2-2		43	<5.0	63	<0.50	120	<0.10	<5.0	<2.5
Dewey Dirt	BA-3-1	9/1/2011	8.1	5.5	62	<0.50	18	<0.10	<5.0	<2.5
Rainbow Valley	BA-4-1	9/12/2011	<5.0	6.1	77	<0.50	7.4	<0.10	<5.0	<2.5
	BA-4-2		<5.0	7.1	93	<0.50	8.7	<0.10	<5.0	<2.5
MDI Phoenix	BA-5-1		7.4	5.9	80	<0.50	15	<0.11	<5.0	<2.5
	BA-5-2		7.3	5.8	90	<0.50	16	<0.091	<5.0	<2.5
Dewey Dirt	BA-3-2	11	5.4	64	<0.50	14	<0.10	<5.0	<2.5	
	BA-3-3	8.2	5.7	73	<0.50	16	<0.10	<5.0	<2.5	
G&S Prescott Valley	BA-2-3	9/14/2011	37	8.3	54	<0.50	57	<0.10	6.5	<2.5
	BA-2-5		17	16	73	<0.50	15	<0.10	<5.0	<2.5
Prescott Dirt	BA-7-1		<5.0	<5.0	77	<0.50	15	<0.11	<5.0	<2.5
Prescott Dirt	BA-7-2	9/16/2011	5.1	<5.0	81	<0.50	18	<0.10	<5.0	<2.5
	BA-7-3		<5.0	<5.0	70	<0.50	18	<0.10	<5.0	<2.5
13030 E. Main Street (sampled from delivered pile)	BA-OFS-103-Top-9/22/11	9/22/2011	6.8 J	<5.0	69	<0.50	17	<0.10	<5.0	<2.5
	BA-OFS-103-Common-9/22/11		9.0 J	8.2 J	110	<0.50	24	<0.10	<5.0	<2.5
MDI Phoenix	MDI-Glendale-Topsoil	9/23/2011	11	6.4	110 J	<0.50	25	<0.10	<5.0	<2.5
	MDI-RG-Common		10	9.1	120 J	<0.50	25	<0.10	<5.0	<2.5
	MDI-MG-Topsoil		<5.0	8.4	87 J	<0.50	12	<0.10	<5.0	<2.5
MDI Glendale	MDI-GD-Common-001	9/28/2011	8.9	<5.0	NA	NA	NA	NA	NA	NA
	MDI-GD-Common-002		8.3	5.7	NA	NA	NA	NA	NA	NA
Arrowhead	Arrowhead-BA-6-1	9/12/2011	11	8.6	73	<0.50	4.0	<0.10	<5.0	<2.5
	Arrowhead-Common-001	9/29/2011	14	8.8	NA	NA	NA	NA	NA	NA
	Arrowhead-Common-002		13	8.8	NA	NA	NA	NA	NA	NA
	Arrowhead-Common-003	10/4/2011	15	9.9	NA	NA	NA	NA	NA	NA
	Arrowhead-Common-004		15	11	NA	NA	NA	NA	NA	NA
	Arrowhead-Common-005		16	12	NA	NA	NA	NA	NA	NA
	Arrowhead-Common-006		14	10	NA	NA	NA	NA	NA	NA
	Arrowhead-Common-007	10/13/2011	12	7.6 J	77	<0.50	5.5 J	<0.10	<5.0	<2.5
	Arrowhead-Common-008		12	8.0 J	99	<0.50	7.3 J	<0.10	<5.0	<2.5
	Arrowhead-Common-009		15	9.6 J	110	<0.50	7.9 J	<0.10	<5.0	<2.5
Arrowhead-Common-010	14		8.9 J	110	<0.50	7.9 J	<0.10	<5.0	<2.5	
North Country	NCLS-Topsoil-001	9/29/2011	<5.0	<5.0	NA	NA	NA	NA	NA	NA

Notes:
J - Estimated concentration
NA - Not analyzed
Results in **bold** exceed site-specific action level

Table 4
Analytical Results for Confirmation Samples
Iron King Mine - Humboldt Smelter Removal

TDD No. 02-09-11-08-0005

Project No. 002693.2155.01RF

OFS Number and Address	Sample Description (depth)	Date Collected	Result (mg/kg)	
			Arsenic	Lead
OFS-002 (STP) 12470 East Yavapai Road	OFS-002-001-002 (excavation floor)	10/29/2011	24	11
	OFS-002-002-002 (excavation floor)	10/29/2011	25	12
	OFS-002-004-072 (gray sludge material)	10/29/2011	5000	5100
	OFS-002-006 (excavation floor)	11/1/2011	42	42
	OFS-002-007 (excavation floor)	11/1/2011	110	71
	OFS-002-008 ("berm soil")	11/1/2011	86	85
	OFS-002-009 (tailings wall)	11/1/2011	1300	2000
	OFS-002-010 (excavation floor)	11/3/2011	21	6.1
	OFS-002-011 (excavation floor)	11/3/2011	18	<5.0
	OFS-002-012 (reddish "tailings")	11/3/2011	190	31
	OFS-002-013 (excavation floor)	11/3/2011	43	25
	OFS-002-014 (excavation floor)	11/9/2011	67 J	65 J
	OFS-002-016 (excavation floor)	11/9/2011	50 J	32 J
	OFS-002-017 (excavation floor)	11/10/2011	200 J	160
OFS-002-018 (excavation floor)	11/10/2011	22 J	9.1	
OFS-002-019 (excavation floor)	11/10/2011	56 J	47	
OFS-103 13030 East Main Street	OFS-103 001 (2 foot)	9/27/2011	62	180
OFS-111 2925 Sweet Pea Lane	OFS-111-001 (2 foot) below shed	9/15/2011	170	460
	OFS-111-002 (1 foot)	9/19/2011	84	460
	OFS-111-003 (1 foot)		160	620
	OFS-111-004 (1 foot)		180	880
	OFS-111-005 (1 foot)		190	820
	OFS-111-006 (2 foot) (same location as -004)	9/26/2011	120	390
	OFS-111-007 (2 foot) (same location as -002)		140	290
	OFS-111-008 (2 foot) (same location as -003)		180	570
OFS-111-009 (2 foot) (same location as -005)	160		610	
OFS-118 2905 Sweet Pea Lane	OFS-118-001 (2 foot)	10/6/2011	95	310
	OFS-118-002 (2 foot)	10/7/2011	85	400
	OFS-118-003 (2 foot)		250	820 J
	OFS-118-004 (2 foot)		98	620 J
OFS-132 2875 South Third Street	OFS-132-001 (1 foot)		9/17/2011	100
	OFS-132-002 (1 foot)	20		52
	OFS-132-003 (1 foot)	130		480
	OFS-132-004 (1 foot)	200		1400
	OFS-132-005 (2 foot) (same location as -004)	10/3/2011	93	320
	OFS-132-006 (2 foot) (same location as -002)		14	23
	OFS-132-007 (2 foot) (same location as -001)		52	400
	OFS-132-008 (2 foot) ((same location as -003)		150	660
OFS-133 and OFS-119 13070 Main Street	OFS-133-001 (2 foot)	10/11/2011	320	1000 J
	OFS-133-002 (2 foot) ¹	10/13/2011	71	220 J
	OFS-133-003 (2 foot)	10/12/2011	240	720 J
	OFS-133-004 (2 foot)	10/24/2011	90	280
OFS-148 2945 Sweet Pea Lane	OFS-148-001 (1 foot)	9/15/2011	180	760
	OFS-148-002 (1 foot)		200	850
	OFS-148-003 (1 foot)		29	67
	OFS-148-004 (1 foot)	9/16/2011	120	470
	OFS-148-006 (2 foot) (same location as -003)	9/21/2011	69 J	450 J
	OFS-148-007 (2 foot) (same location as -002)		120 J	470 J
	OFS-148-008 (2 foot) (same location as -001)		290 J	1500 J
	OFS-148-009 (2 foot) (same location as -004)		93 J	380 J
OFS-208 and OFS-244 2575 Hill Street/2565 Hill Street	OFS-244/208 (2 foot)	10/3/2011	26	18
OFS-260 City Right-of-Way	OFS-260-001 (pothole composite, 1foot)	9/27/2011	220	870
	OFS-260-002 (composite, 2 foot)	10/5/2011	200	700
	OFS-260-003 (partial pothole composite, 2 foot)		75	330
OFS-301 2965 Sweet Pea Lane	OFS-301-001 (2 foot) outside of fence	9/26/2011	110	770
	OFS-301-002 (2 foot)	9/27/2011	69	230
OFS-306 13087 East Main Street 13089 East Main Street	OFS-306-001 (1 foot)	9/17/2011	23	41
	OFS-306-002 (1 foot)		54	81
	OFS-306-003 (2 foot) (same location as -001)	9/26/2011	29	59
	OFS-306-004 (2 foot) (same location as -002)		52	180

Notes:

J - Estimated concentration
mg/kg - milligrams per kilogram

Results in **bold** exceed the site-specific action levels for arsenic or lead of 38 mg/kg or 23 mg/kg, respectively.

¹ - This sample is from the area on the southeast side of OFS-133 and northwest side of OFS-119.

Table 5
 STP Gray Sludge Material CAM-17 Metals and Total Cyanide Results
 STP Sample ID IKMHSR-OFS-002-004-072
 Iron King Mine - Humboldt Smelter Removal
 Sample Collected October 29, 2011
 Results in milligrams per kilogram

TDD No. 02-09-11-08-0005

Project No. 002693.2155.01RF

Analyte	TTLIC	Site-Specific Action Level	Sample Result
Antimony	500	none	40 J
Arsenic	500	38	5,000
Barium	10,000	5,300	26
Beryllium	75	none	<0.50
Cadmium	100	38	120
Chromium	2,500	2,100	13
Cobalt	8,000	none	18
Copper	2,500	none	800
Lead	1,000	23	5,100
Mercury	20	6.7	17
Molybdenum	3,500	none	5.2
Nickel	2,000	none	14
Selenium	100	380	31
Silver	500	380	36
Thallium	700	none	<5.0
Vanadium	2,400	none	29
Zinc	5,000	none	48,000
Total Cyanide	NA	none	1.9

Notes:

CAM-17 - California Assessment Manual 17 metals

J - Estimated concentration

NA - Not applicable

TTLIC - California Title 22 Total Threshold Limit Concentration

Results in **bold** exceed site-specific action levels

2012 ecology and environment, inc.

**Sampling and Analysis Plan
Iron King Mine – Humboldt Smelter
Removal
Yavapai County, Arizona**

**TDD No.: TO-02-09-11-08-0005
Project No.: 002693.2155.01RF**

September 2011

Prepared for:

**U.S. ENVIRONMENTAL PROTECTION AGENCY
Region IX**

Prepared by:

ECOLOGY AND ENVIRONMENT, INC.
3700 Industry Avenue, Suite 102
Lakewood, CA 90712

Superfund Technical Assessment and Response Team

Sampling and Analysis Plan
Iron King Mine – Humboldt Smelter Removal
Yavapai County, Arizona

TDD No.: TO2-09-11-08-0005
Project No.: 002693.2155.01RF

September 2011

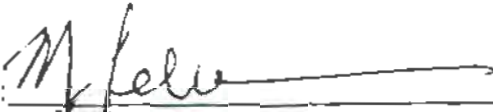
Approved by: 
Michael Schwennesen, START Project Manager
Ecology and Environment, Inc.

Approved by:  9/1/2011
Howard Edwards, START Quality Assurance Coordinator
Ecology and Environment, Inc.

Approved by: 
Craig Ballson,
Federal On Scene Coordinator
U.S. Environmental Protection Agency, Region IX

Approved by: _____
Eugenia McNaughton, Ph.D., Quality Assurance Officer
U.S. Environmental Protection Agency, Region IX

Table of Contents

Section	Page
1	Introduction 1-1
1.1	Project Organization..... 1-2
1.2	Distribution List 1-2
1.3	Statement of the Specific Problem 1-2
2	Site Background.....2-1
2.1	Site Location and Description 2-1
2.2	Previous Investigation and Activities..... 2-2
2.2.1	ADEQ 2-2
2.2.2	U.S. EPA / START 2005 2-2
2.2.3	U.S. EPA / EA Engineering, Science and Technology, Inc..... 2-2
2.2.4	U.S. EPA / START 2010-2011 2-3
3	Project Objectives3-1
3.1	Data Use Objectives 3-1
3.2	Project Sampling Objectives 3-1
3.3	Action Levels 3-2
3.4	Data Quality Objectives 3-5
3.5	Data Quality Indicators (DQIs) 3-5
3.6	Schedule of Sampling Activities 3-5
3.7	Special Training Requirements/Certifications 3-5
4	Sampling Rationale and Design.....4-1
4.1	Analytes of Concern..... 4-1
4.2	Borrow Material Sampling..... 4-1
4.3	Residential Properties Sampling 4-1
4.4	Small Tailings Pile Sampling 4-2
4.5	Ambient Air Sampling 4-2
5	Request for Analyses.....5-1
5.1	Laboratory Analysis 5-1
6	Field Methods and Procedures6-1
6.1	Field Procedures 6-1
6.1.1	Standard Operating Procedures and Equipment..... 6-1
6.1.2	Equipment Maintenance..... 6-1

Table of Contents (cont.)

Section	Page
6.1.3	Inspection/Acceptance Requirements for Supplies and Consumables 6-1
6.1.4	Logbooks 6-1
6.1.5	Photographs 6-2
6.1.6	Electronic Sample Logging 6-3
6.1.7	Mapping Equipment 6-3
6.2	Soil Sampling Procedures 6-3
6.2.1	Discrete Sampling 6-3
6.2.2	Composite Sampling 6-3
6.2.2.1	Borrow Material Sampling 6-3
6.2.2.2	Pre-Excavation Soil Sampling 6-4
6.2.2.3	Post-Excavation Soil Sampling 6-4
6.3	Air Sampling Procedures 6-4
7	Disposal of Investigation-Derived Waste 7-1
8	Sample Identification, Documentation and Shipment 8-1
8.1	Sample Nomenclature 8-1
8.2	Container, Preservation, and Holding Time Requirements 8-1
8.3	Sample Labeling, Packaging, and Shipping 8-2
8.4	Chain-of-Custody Forms and QA/QC Summary Forms 8-3
9	Quality Assurance and Control (QA/QC) 9-1
9.1	Field Quality Control Samples 9-1
9.1.1	Assessment of Field Contamination (Blanks) 9-1
9.1.1.1	Equipment Blank Samples 9-1
9.1.1.2	Field Blanks 9-1
9.1.2	Assessment of Sample Variability (Field Duplicate or Co-located Samples) 9-1
9.1.3	Laboratory Quality Control (QC) Samples for Soil 9-1
9.2	Analytical and Data Package Requirements 9-2
9.3	Data Management 9-2
9.4	Data Validation 9-3
9.5	Field Variances 9-4
9.6	Assessment of Project Activities 9-4
9.6.1	Assessment Activities 9-4
9.6.2	Project Status Reports to Management 9-5
9.6.3	Reconciliation of Data with DQOs 9-5
10	References 10-1
A	Data Quality Objective Process Document A-1
B	Site Specific Health and Safety Plan B-1

Table of Contents (cont.)

Section	Page
C Standard Operating Procedures	C-1



List of Tables

Figure 2-2 Site Location Map..... 2-1

Table 2-1 Properties Subject to U.S. EPA Time-Critical Removal Action 2-2

Table 3-1 3-3

Benchmarks and Data Quality Indicator Goals – 3-3

Definitive Data for EPA Method 6010B/7471A in Borrow Soil Samples and Post-
Removal Confirmation Samples..... 3-3

Table 3-2 3-4

Benchmarks and Data Quality Indicator Goals - Definitive Data for..... 3-4

NIOSH Method 7300 Air Sample Analysis..... 3-4

Table 5-1 Assessment Sampling and Analysis Summary 5-2

List of Figures

Figure 2-1 Site Map..... 2-4

Figure 2-2 Site Location Map..... 2-1

Figure 6-1 Example Air Sampling Form..... 6-1



List of Abbreviations and Acronyms

ADEQ	Arizona Department of Environmental Quality
bgs	below ground surface
COPC	contaminant of potential concern
DQI	Data Quality Indicator
DQO	Data Quality Objective
EA	EA Engineering, Science and Technology, Inc.
E&E	Ecology and Environment, Inc.
ERS	Emergency Response Section
FOSC	Federal On-Scene Coordinator
ft ²	square foot
GPS	Global Positioning System
IDW	investigation-derived waste
LCS	laboratory control sample
MS/MSD	matrix spike/matrix spike duplicate
mg/kg	milligrams per kilogram
NIOSH	National Institute for Occupational Safety and Health
OSHA	U.S. Occupational Safety and Health Administration
PM	Project Manager
PPE	personal protective equipment
QA	quality assurance
QC	quality control

List of Abbreviations and Acronyms (cont.)

RI Report	Remedial Investigation Report
RPD	relative percent difference
RSL	Regional Screening Level
SAP	Sampling and Analysis Plan
SOP	standard operating procedure
SRL	Arizona Soil Remediation Level
STP	Small Tailings Pile
START	Superfund Technical Assessment and Response Team
TDD	Technical Direction Document
TCRA	time-critical removal action
TM	Task Monitor
UCL	upper confidence limit
U.S. EPA	United States Environmental Protection Agency

1 Introduction

The United States Environmental Protection Agency (U.S. EPA) tasked Ecology and Environment, Inc.'s (E & E's) Superfund Technical Assessment and Response Team (START) to support a U.S. EPA-funded removal at the Iron King Mine – Humboldt Smelter Superfund Site (the site), located in Dewey-Humboldt, Arizona. In order to support the U.S. EPA's environmental data collection activities, the START has identified project data quality objectives and developed this Sampling and Analysis Plan (SAP).

Beginning September 12, 2011, the U.S. EPA Region IX Emergency Response Section (ERS) will conduct a time-critical removal action (TCRA) to remove arsenic- and lead-contaminated soil from 13 properties within a residential neighborhood at the site. The 13 properties were identified through START assessment activities described in the document, *Iron King Mine – Humboldt Smelter Assessment Report, Dewey-Humboldt, Yavapai County, Arizona* (August 2011)(technical direction document [TDD] No. T02-09-10-09-0004).

Sampling activities described in this SAP will include:

- Surface and sub-surface sampling of borrow material to ensure that clean soil is used to replace the removed soil;
- Surface soil sampling during excavation activities to determine whether contamination is still present.
- Post-excavation surface soil sampling to document concentrations of arsenic and lead in an excavated area; and
- Air sampling to document concentrations of arsenic and lead in ambient air during removal activities.

With the exception of the borrow samples which will be analyzed for eight metals (including arsenic and lead), the only analyses conducted under this SAP will be for arsenic and lead.

The scope of work and objectives outlined in this SAP are derived from the direction of the U.S. EPA. This SAP describes the project and data use objectives, data collection rationale, data quality assurance goals, and requirements for sampling and analysis activities. It also defines the sampling and data collection methods that will be used for this project. This SAP is intended to accurately reflect the planned data-gathering activities for this support activity. However, site conditions, budget, and additional U.S. EPA direction may warrant modifications. All significant changes are to be documented in site records.

The specific field sampling and chemical analysis information in this SAP was prepared in accordance with the following U.S. EPA documents: EPA Requirements for Quality Assurance Project Plans (EPA QA/R 5, March 2001, EPA/240/B 01/003); Guidance on Systematic Planning Using the Data Quality Objectives Process (EPA QA/G 4, February 2006, EPA/240/B-06/001); Guidance on Choosing a Sampling Design for Environmental Data Collection (EPA QA/G 5S, December 2002, EPA/240/R 02/005); Superfund Lead-Contaminated Residential Sites

Handbook (OSWER 9285.7-90, August 2003); and Uniform Federal Policy for Implementing Environmental Quality System (EPA/505/F-03/001, March 2005).

1.1 Project Organization

U.S. EPA Federal On-Scene Coordinator (FOSC) – The U.S. EPA FOSC is Mr. Craig Benson. Mr. Benson is the primary decision-maker and will direct the project, specify tasks, and ensure that the project is proceeding on schedule and is within budget. Additional duties include coordination of communication with the START Project Manager, U.S. EPA Quality Assurance (QA) Office, and community residents.

START Project Manager (PM) – Mr. Michael Schwennesen is the START PM. The PM manages the project's data collection efforts and is responsible for implementing the SAP, coordinating project tasks and field sampling, managing field data, and completing all preliminary and final reporting.

Principal Data Users – Data generated during the implementation of this SAP will be utilized by the FOSC to make decisions regarding the removal activities.

START Quality Assurance Coordinator – Mr. Howard Edwards is responsible for the development of this SAP. Specifically, Mr. Edwards is responsible for the documentation of project objectives and for preparation and review of the draft and final SAP document. Mr. Edwards will coordinate with the U.S. EPA's Quality Assurance Office as needed.

Sample Analysis and Laboratory Support – Mr. Erik Faasen of TestAmerica laboratory in Phoenix, Arizona will be responsible for all sample analyses. TestAmerica contact information is provided below:

TestAmerica
4625 E Cotton Center Blvd. Suite 189
Phoenix, AZ 85040
Tel 602-437-3340

1.2 Distribution List

Copies of the final SAP will be distributed to the following persons and organizations:

- Craig Benson, U.S. EPA Region IX
- U.S. EPA Region IX, Quality Assurance Office
- E & E START Field Team
- E & E START project files

1.3 Statement of the Specific Problem

The U.S. EPA will perform a TCRA at 13 properties at the site that have been documented to be contaminated with arsenic and lead at concentrations that exceed the US EPA's site-specific action levels. Analytical data is need to confirm that the soil in the borrow areas which will be



1. Introduction

used as backfill is not also contaminated with arsenic, lead, or any other of the eight Resource Conservation and Recovery Act metals (RCRA 8 metals).

After the excavation, analytical data is needed to document a successful removal or document post-removal remaining subsurface concentrations of arsenic and lead. Ambient air samples will also be collected to document concentrations of arsenic and lead in ambient air during removal operations. The site-specific action levels for arsenic and lead are currently established at 38 and 23 milligrams per kilogram (mg/kg), respectively. The action levels for barium, cadmium, chromium, mercury, selenium and silver in soil are listed in Table 3-1.

2 Site Background

2.1 Site Location and Description

The Iron King Mine – Humboldt Smelter site is located in Dewey-Humboldt, Yavapai County, Arizona (Figure 2-1). The approximate geographical coordinates of the Dewey-Humboldt town hall are latitude 34.503043° north; longitude 112.243559° west. The town of Dewey-Humboldt was incorporated on December 20, 2004 from the existing unincorporated towns of Dewey and Humboldt, located adjacent to one another in the Agua Fria River Valley, 11 miles east of Prescott. Dewey-Humboldt is located between the mine and the smelter (Figure 2-2). The population of the town was 3,613 in 2005 according to a census estimate. Three waterways (Chaparral Gulch, Galena Gulch, and Agua Fria River) transect the site.

The Iron King Mine property is approximately 153 acres in size. It is located west of Highway 69, bordered by the Chaparral Gulch and residences to the north; Highway 69 to the east; Galena Gulch to the south; and undeveloped land to the west. The Iron King Mine was a periodically-active gold, silver, copper, lead, and zinc mine from 1906 until 1969. The present owner of the 85-acre portion of the Iron King Mine area of interest referred to as the Iron King Mine Proper Area is North American Industries (NAI), which produces Hydromax fertilizers and soil supplements. Previous ownership included Ironite Products Company, which marketed Ironite fertilizer produced from mine tailings from 1989 to 2006. The principal feature of the Iron King Mine Proper Area is a large (more than 50 acres) tailings pile, which contains high concentrations of arsenic and lead. The tailings are subject to off-site migration mainly via air particulate migration and surface water transport.

The Humboldt Smelter property is located less than one mile east of the Iron King Mine property, on the east side of Highway 69. The approximately 189-acre smelter property is bounded by residences to the north and west; the Agua Fria River to the east; and Chaparral Gulch to the south. The majority of the Humboldt Smelter is owned by Greenfields Enterprises, LLC, which purchased the property in 2003. No businesses are currently operating on the property. The Humboldt Smelter area of interest includes tailings and slag deposit areas and an approximately 23-acre ash pile. The ash pile material is subject to off-site migration mainly via air particulate migration and surface water transport.

One of the 13 properties subject to the TCRA contains a small tailings pile (STP) of approximately 12,000 to 20,000 cubic yards. The STP will be moved onto the Iron King Mine

tailings pile as part of the TCRA. The STP contains relatively high concentrations of arsenic and lead and detectable concentrations of cyanide, and is located immediately to the north of the Iron King Mine Proper Area on a 40-acre private parcel designated as OFS-0021. Although located on private residential property, the STP has been associated with historical mining activities at the Iron King Mine.

2.2 Previous Investigation and Activities

2.2.1 ADEQ

In April 2002, the Arizona Department of Environmental Quality (ADEQ) sampled sediment near residential parcels throughout the Chaparral Gulch as part of a Preliminary Assessment/Site Inspection. The investigation revealed arsenic concentrations of up to 509 milligrams per kilogram (mg/kg) and lead concentrations of up to 513 mg/kg.

2.2.2 U.S. EPA / START 2005

In 2005, ADEQ requested that the U.S. EPA assess surface soils at residential properties in the vicinity of the Chaparral Gulch and Iron King Mine. In response to the request, the U.S. EPA and START conducted a site assessment of 17 properties along the Chaparral Gulch (E & E, 2005). Soil samples were collected to determine arsenic and lead concentrations on these properties. Ten samples were collected from each property, which included nine surface samples (0-6 inches bgs) and one subsurface sample (18 inches bgs). Analytical results from the sampling event identified lead and arsenic concentrations in surface soil samples at four of the properties that were sufficiently high to warrant a removal action. The removal action was conducted by Brown and Caldwell in late 2006 (EA, 2010).

2.2.3 U.S. EPA / EA Engineering, Science and Technology, Inc.

In 2008, the Iron King Mine – Humboldt Smelter site was listed on the National Priorities List and a Remedial Investigation (RI) was conducted by EA for the U.S. EPA’s Remedial Program. From 2008 to 2010, as part of the RI, EA collected soil samples at 168 parcels within the town. The parcels sampled were selected from areas suspected of being impacted by historical mining and smelting operations (based on wind patterns) and where homeowner sampling access agreements could be obtained. The objective of the RI sampling was to identify levels of metals contamination in soil resulting from the site, and specifically to evaluate impacts on the community of Dewey-Humboldt. Nine discrete samples from the 0 to 2-inch depth interval and

ii

ii

¹ Previous site studies at the Iron King Mine – Humboldt Smelter used the term “OFS”, which stands for “off-site soil”, to describe in-town soil sample properties. To avoid confusion when comparing new data to old data for particular properties, the convention of using “OFS” is continued in this assessment although the properties are no longer considered “off site.”

one discrete sample from the 10 to 12-inch depth interval were collected at each parcel. The deeper-depth interval was selected at random from beneath one of the nine surface sample locations. The nine surface sample locations were selected on a parcel-by-parcel basis (judgmentally) with an attempt to be spatially representative while taking into account site features (e.g., driveways and landscaping) and roof drainage patterns. The RI samples were analyzed for 23 “target analyte list” metals, including arsenic and lead.

Also as part of the RI, EA collected background soil samples from several different soil types and areas about the site. Background Soil Type 1 was identified as the predominant soil type for the study area, and a background concentration of 48 mg/kg for arsenic and 44 mg/kg for lead was established (EA, 2010). A subsequent addendum to the EA RI report revised the average background concentrations of arsenic and lead in Soil Type 1 to 38 and 23 mg/kg, respectively (EA 2011).

EA tabulated analytical data for the 185 in-town parcels sampled (including the 17 parcels sampled by the START in 2005). EA also calculated the 95% upper confidence limit (UCL) on the arithmetic mean from the sample data for each parcel, following U.S. EPA guidance and using U.S. EPA’s ProUCL 4.0 software. This summary data was used by the U.S. EPA in 2010 to determine what properties would be subject to the TCRA.

2.2.4 U.S. EPA / START 2010-2011

In the fall of 2010, the U.S. EPA Remedial Program requested that the U.S. EPA Emergency Response Section provide support to conduct an RA at the site. To determine which in-town properties to investigate for the RA, the START prepared an interim “hot list” of residential and city-owned properties that had already been sampled and that could potentially be candidates for a removal action. To compile the list, the START used the EA table presenting data for 185 in-town properties, which included average concentrations and 95% UCLs for arsenic and lead in soil for each property. Each property was then placed on a list of descending order (highest to lowest) based on its calculated 95% UCL concentration of arsenic and/or lead. In order to limit the initial scope of the RA and the potential removal actions to those properties that could be considered time critical, the U. S. EPA determined that only the upper 10 percent of the in-town properties (as ranked by relative arsenic and/or lead contamination) would be placed on the hot list. Properties with 95% UCLs for arsenic that were greater than or equal to 165.2 mg/kg and properties with 95% UCLs for lead that were greater than or equal to 512.7 mg/kg were designated for the interim hot list. Some properties were identified for the interim hot list based on the 95% UCLs for both arsenic and lead.

During several site visits which included sampling activities, the U.S. EPA and the START eventually reduced the number of properties to be subjected to the TCRA to 13 properties. Table 2-1 lists the 13 properties. Figures showing these properties are available in the Work Plan.

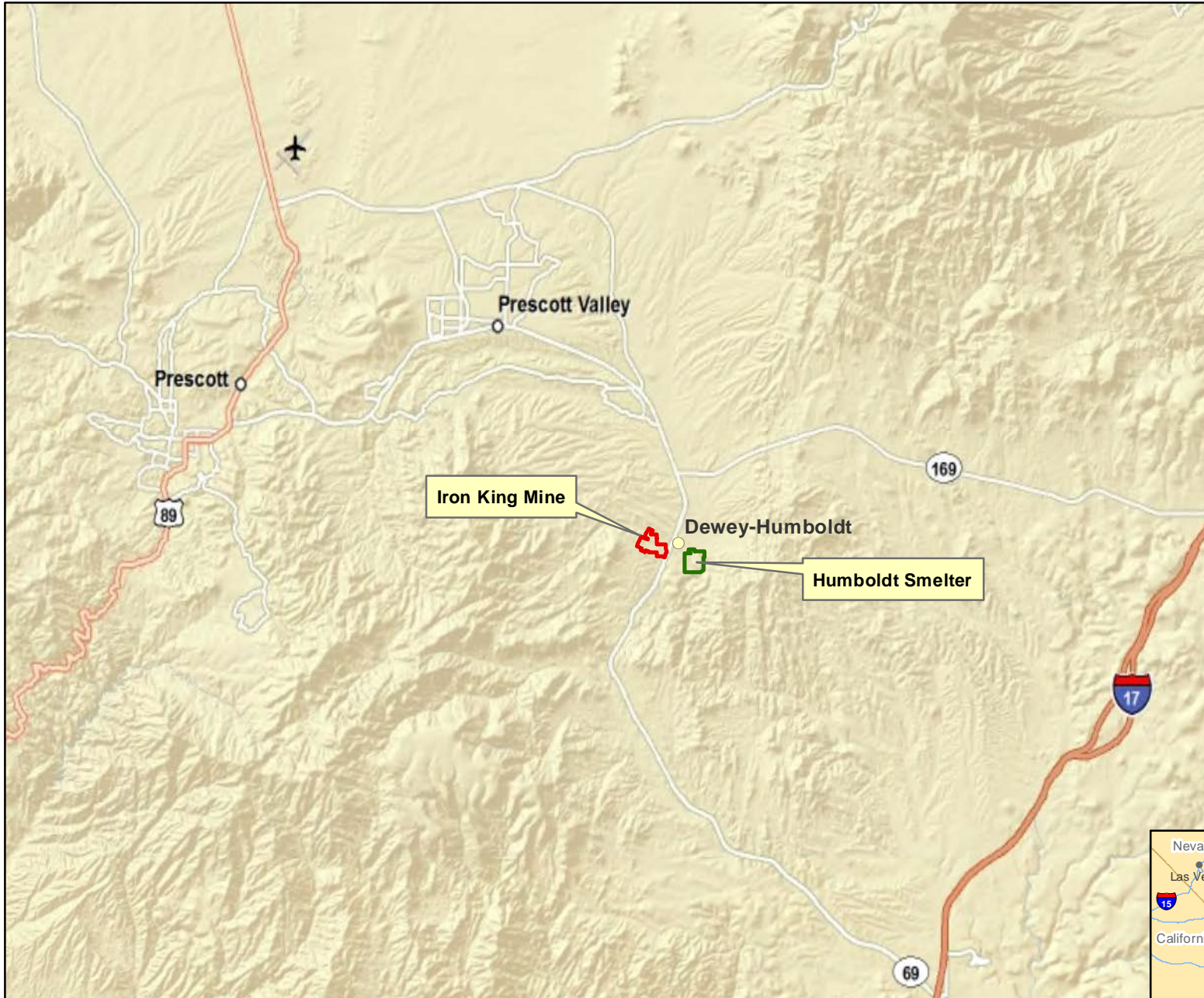

Legend

- Iron King Mine
- Humboldt Smelter

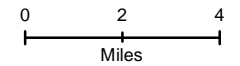

Source:
Background: ESRI World Street Map



Figure 2-1
Site Location Map

Iron King Mine - Humboldt Smelter Assessment Site
Dewey-Humboldt, Yavapai County, Arizona

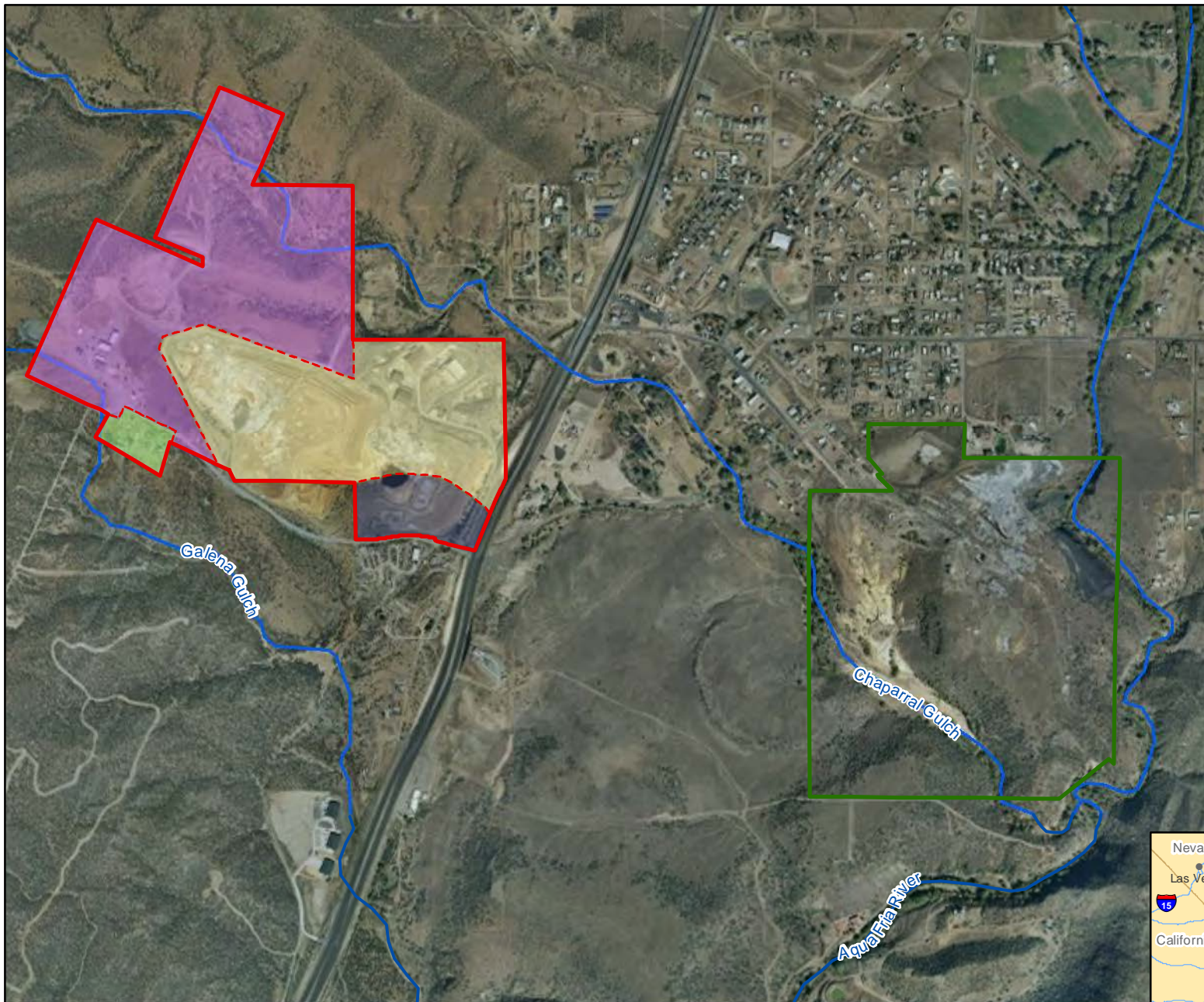

Legend

- Iron King Mine**
- Iron King Mine Proper Area
- Iron King Operations Center
- Former Fertilizer Plant Area
- Salvage Yard
- Humboldt Smelter**

- ~ **Waterways**
Chaparral Gulch, Galena Gulch, Agua Fria River



0 500 1,000
Feet

Source:
Aerial Photo: ESRI World Imagery
EA Remedial Investigation Report,
Revision 01, March 2010



**Figure 2-2
Site Map**

**Iron King Mine - Humboldt Smelter Assessment Site
Dewey-Humboldt, Yavapai County, Arizona**

Table 2-1
Properties Subject to U.S. EPA Time-Critical Removal Action
Dewey-Humboldt, Arizona

E & E Project No. 002693.2155.01.RF

TDD No. TO2-09-11-08-0005

	Site ID	Parcel No.	Physical Address	Mailing Address	Acres	Arsenic		Lead	
						Average Concentration (mg/kg)	95% UCL ¹	Average Concentration (mg/kg)	95% UCL ¹
Complete Removal	OFS 111	402-06-102L	2925 South Sweet Pea Lane	PO Box 485 Humboldt, AZ 86329	0.27	115.6	165.2	638.8	923.9
	OFS 118	402-06-102K	2905 South Sweet Pea Lane	PO Box 508 Humboldt, AZ 86329	0.27	147.2	198.4	1148	1610
	OFS 132	402-06-102P	2875 South Third Street	PO Box 122 Humboldt, AZ 86329	0.25	102.5	130.7	949.7	1792
	OFS 260	800-27-005T	Unsurfaced right-of-way behind Sweet Pea Lane	Municipal property	0.5 (approx.)	157.6	205.9	746.8	1025
	OFS 148	402-06-102M	2945 Sweet Pea Lane	1575 Purple Sage Road Chino Valley, AZ 86323	0.27	106.1	133.1	577.5	692.9
	OFS 133 ² OFS-119 (NE corner of OFS-119 added to removal at OFS-133)	402-07-006	13070 Main Street	PO Box 338 Humboldt, AZ 86329	0.23	284.6	383.3	1132	1584
Hot-Spot Removal		402-07-007C	13080 East Main Street	PO Box 552 Humboldt, AZ 86329	0.48 ⁴				
	OFS-103	402-07-002B	13030 East Main Street	PO Box 488 Humboldt, AZ 86329	0.46 ⁴	45.77 ⁵	92.86 ^{5,6}	134.5 ⁵	605.3 ^{5,6}
	OFS 208 ² OFS-244 (one hot spot between two parcels)	402-09-016D	2565 Hill Street	PO Box 32 Humboldt, AZ 86329	0.21 ⁴	134.9	481 ⁷	108.7	355.8 ⁷
		402-09-016H	2575 Hill Street	PO Box 548 Humboldt, AZ 86329	0.21 ⁴				
	OFS-002 ² (hot spot is the STP)	402-08-034A	12470 East Yavapai Road	PO Box 721 Dewey, AZ 86327	0.6 ³	556.4	727.2	706.2	986.8
	OFS-301	402-06-102N	2965 Sweet Pea Lane	PO Box 905 Humboldt, AZ 86329	0.28 ⁴	52.02	128.5 ⁷	241	552 ⁶
OFS-306	402-06-026 402-06-027B	13087 E. Main Street 13089 E. Main Street	PO Box 699 Humboldt, AZ 86329	0.19 ⁴ 0.32 ⁴	70.8	111.3 ⁶	187	259.7	

¹ - Calculated as student's t-test for normal distribution unless otherwise noted.

² - For properties that were sampled by both EA and START, the START data was combined with EA data to generate new means and 95% UCLs.

³ - The Small Tailings Pile has an area of approximately 0.6 acres and is situated on a parcel of approximately 40 acres.

⁴ - These properties will be subjected to hot spot removals only.

⁵ - Calculated based on samples listed in Table 15.

⁶ - Gamma UCL

⁷ - Non-parametric Chebyshev UCL

3 Project Objectives

3.1 Data Use Objectives

Based on available information documented by the previous investigations and at the request of the Remedial Program of the U.S. EPA, the U.S. EPA ERS is conducting a TCRA to:

- Remove surface and near-surface soils from 13 site properties in order to reduce arsenic and lead exposure risk to human health and the environment.

The lead, arsenic, and RCRA 8 metals concentration data generated by this assessment will be used to:

- Ensure that borrow soil concentrations of RCRA 8 metals are at or below the concentrations presented in Table 3-1.
- Direct additional excavation activities for depths below one foot bgs.
- Confirm a successful arsenic- and lead-contaminated soil removal or document post-removal remaining subsurface concentrations of arsenic and lead.
- Document the concentrations of arsenic and lead in ambient air collected during removal activities.

Analytical data collected as part of the TCRA will be used to answer the following site-specific study questions:

What are the RCRA 8 metals concentrations in borrow soil?

What are the arsenic and lead concentrations in post-removal “confirmation” soil samples?

What are the concentrations of arsenic and lead in air samples collected downwind of the site during soil removal operations?

3.2 Project Sampling Objectives

The data obtained through the implementation of this SAP will be used to ensure that clean backfill soil is used at 12 of the residential properties (the STP property will not receive backfill), and to either document a need for additional soil removal or document post-removal concentrations of arsenic and lead in soil. No borrow material will be used for backfill unless it achieves the action levels listed in Table 3-1. If arsenic and/or lead exceed the action levels of Table 3-1 in confirmation samples collected after a one-foot lift of soil is removed from a particular property, an additional one-foot lift of soil will be removed. At the two-foot depth, “confirmation” samples will again be collected but only to document arsenic and lead concentrations at that depth. No further removal will occur below a depth of two feet below ground surface (bgs).



Soil and air sampling, followed by definitive laboratory sample analysis, will be performed to accomplish the project objectives. Sampling objectives include:

- Obtain data for RCRA 8 metals concentrations in soil that can be used to determine whether the borrow soil can be used as backfill material.
- Determine whether arsenic and lead concentrations in confirmation samples are below the site-specific action levels.
- Document arsenic and lead concentrations in surface soil samples collected during removal operations.
- Document arsenic and lead concentrations in air samples collected during removal operations.

3.3 Action Levels

The site-specific action levels for the TCRA were determined by FOSC Benson and are presented in Tables 3-1 and 3-2. These tables also present information regarding data quality indicator goals for this project.

**Table 3-1
Benchmarks and Data Quality Indicator Goals –
Definitive Data for EPA Method 6010B/7471A in Borrow Soil Samples and Post-Removal Confirmation Samples
Iron King Mine – Humboldt Smelter Removal
Yavapai County, Arizona**

E & E Project No. 002693.2155.01.RF

TDD No. TO2-09-11-08-0005

Constituent	Site-Specific Action Level for Confirmation Samples ¹ (mg/kg)	Site-Specific Action Level for Borrow Soil (mg/kg)	Arizona Residential SRL (mg/kg)	U.S. EPA Residential RSL (mg/kg)	TestAmerica (Phoenix) Reporting Limits	Accuracy	Precision	Percent Completeness
						(% Recovery for MS/ MSD)	(RPD from MS/MSD and Duplicates)	
Lead	23	23	400	400	5.0	75 – 125	20%	> 90%
Arsenic	38	38	10	0.39	5.0	75 – 125	20%	> 90%
Barium	NA	5,300	5,300	15,000	5.0	75 – 125	20%	> 90%
Cadmium	NA	38	38	70 ²	0.50	75 – 125	20%	> 90%
Chromium	NA	2,100	2,100	None	2.0	75 – 125	20%	> 90%
Mercury	NA	6.7	6.7	10	0.10	75 – 125	20%	> 90%
Selenium	NA	380	380	390	5.0	75 – 125	20%	> 90%
Silver	NA	380	380	390	2.5	75 – 125	20%	> 90%

Notes:

¹ - Action levels do not apply to the small tailings pile

² - Dietary

mg/kg = milligrams per kilogram

MS/MSD = Matrix Spike/Matrix Spike Duplicate

NA = Not applicable

RSL = U.S. EPA Regional Screening Level (June 2011)

RPD = Relative Percent Difference

SRL = Soil Remediation Level

**Table 3-2
Benchmarks and Data Quality Indicator Goals - Definitive Data for
NIOSH Method 7300 Air Sample Analysis**

**Iron King Mine – Humboldt Smelter Removal
Yavapai County, Arizona**

E & E Project No. 002693.2155.01.RF

TDD No. TO2-09-11-08-0005

Constituent	OSHA PEL (mg/m ³)	TestAmerica (Phoenix) Reporting Limits ¹ (mg/m ³)	Accuracy	Precision	Percent Completeness
			(% Recovery for BS/BSD)	(RPD from BS/BSD and Duplicates)	
Lead	0.050	0.0032	80 – 120	25%	> 90%
Arsenic	0.010	0.0026	80 – 120	25%	> 90%

¹ Assumes sample collected at 2 liters per minute over an 8-hour period

mg/m³ = milligrams per cubic meter

BS/BSD = Blank Spike/Blank Spike Duplicate

NIOSH = National Institute for Occupational Safety and Health

OSHA = U.S. Occupational Safety and Health Administration

PEL = Permissible Exposure Level (8-hour time-weighted average)

RPD = Relative Percent Difference

2011 ecology & environment, inc.

3.4 Data Quality Objectives

The data quality objective (DQO) process, as set forth in the U.S. EPA *Guidance on Systematic Planning Using the Data Quality Objectives Process (EPA/240/B-06/001)* (U.S. EPA, 2006), was followed to establish the DQOs for this project. An outline of the process and the outputs for this project are included in Appendix A.

3.5 Data Quality Indicators (DQIs)

Data quality indicators (DQIs) are defined as: precision, accuracy, representativeness, completeness, comparability, and method detection limits. The DQIs for this project were developed following the guidelines in the U.S. EPA *Requirements for Quality Assurance Project Plans* (U.S. EPA, 2001). All sampling procedures are documented in Sections 6.2 and 6.3. Standard operating procedures will be followed to ensure representativeness of sample results by obtaining characteristic samples. Approved U.S. EPA methods and standard reporting limits will be used. All data not rejected will be considered complete. Tables 3-1 and 3-2 document the site-specific DQI goals for lead and arsenic.

3.6 Schedule of Sampling Activities

The field sampling and analysis activities are scheduled to commence on September 12, 2011. The field activities are expected to last approximately 7 weeks.

3.7 Special Training Requirements/Certifications

Data validation requires specialized training and experience. The START PM will ensure that a qualified START chemist will perform a Tier 2 validation of 100 percent of the data (as defined in the U.S. EPA document, *Requirements for Quality Assurance Project Plans* (March 2001). Specific data validation requirements are discussed in Section 9.4.

Field sampling personnel should be trained and have experience with soil sampling at hazardous waste sites while wearing appropriate protective equipment. One field sampler should be trained and familiar with Global Positioning System (GPS) data collection. All sampling personnel must have appropriate training that complies with 29 Code of Federal Regulations 1910.120. The site-specific health and safety plan for this project is to be appended to this plan by project management (Appendix B).

4 Sampling Rationale and Design

The START reviewed available site information, including previous sampling data, and took into account the U.S. EPA FOOSC's objectives for the TCRA to determine the specific sampling design.

Identification of useable borrow material sources and post-removal documentation of arsenic and lead concentrations in residential soils are the principal objectives of the activities described in this SAP. A secondary objective is to collect air samples to document concentrations of arsenic and lead in airborne particulates generated by removal activities.

The locations of the 13 properties which will undergo TCRA removal activities are presented in Table 2-1. Maps of the individual properties are presented in the Work Plan.

The U.S. EPA *Superfund Lead-Contaminated Residential Sites Handbook* (OSWER Directive 9285.7-50 (August, 2003) (Lead handbook) was referenced during development of the sampling design and will be used as a guideline where applicable. Previous sampling methodology has also been considered, in order to obtain data in a similar manner to that historically conducted. After collection, samples will be handled and analyzed according to Sections 5.1, 6.2, and 6.3 of this SAP. Sample locations will be recorded in the field logbook as sampling is completed. Individual sample-point locations will be recorded using GPS equipment, whenever possible.

4.1 Analytes of Concern

The analytes of concern are arsenic and lead. All samples collected in the field will be analyzed for arsenic and lead using TestAmerica laboratory in Phoenix, Arizona. Borrow samples will be analyzed for RCRA 8 metals. The definitive methods to be used are described in Tables 3-1 and 3-2.

4.2 Borrow Material Sampling

Five-point composite samples will be collected from potential borrow sources. One composite sample will be collected for each separate area within a borrow source from which soil may be used for fill material. Composite sample aliquots will be collected from 0 to 6 inches into the soil, and the sample aliquots will be spatially distributed in a manner to achieve a composite sample that well-represents its source. The composite sample aliquots will be collected into a plastic baggie; homogenized; and then transferred into a four-ounce glass jar. Additional borrow samples will be collected from each source periodically, and before soil from a new source is used. Borrow material will not be used for backfill until analytical results have documented that arsenic and lead concentrations are below the action levels

4.3 Residential Properties Sampling

Whether a particular property will undergo a hot spot removal or a removal of all accessible soil, the removal and sampling procedure will be the same. The removal contractor will remove soil to a one-foot depth bgs. Following guidelines in the Lead Handbook, the START will then collect composite samples at the one-foot depth, with one five-point composite sample collected

4. Sampling Rationale and Design

from each front, back, and side yard. This procedure will also be used for individual hot spot removals. If samples from any area (front, back, side yard, or hot spot) exceed the action levels for arsenic and/or lead, another one-foot lift will be removed in that area and another composite sample will be collected. Soil removal will not exceed a two-foot bgs depth. A material such as snow fencing will then be placed at the total removal depth, and clean borrow material will be placed over it to return the area to grade. In certain situations, the FOSC may elect to remove soil directly to a two-foot depth, collect composite samples for documentation purposes, emplace snow fencing, and backfill with borrow material without sampling at the one-foot depth or waiting for analytical results. Such a situation may occur in areas where a minimal amount of disturbance to the homeowner is desired.

Air samples will be collected during the earth-moving activities. Three air samplers will be placed about the work area in approximated upwind, downwind, and crosswind locations. They will be placed, when possible, between the work area and adjacent homes. A weather station will be used to document and archive wind direction and velocity. Locations of the air samplers and weather station will be documented in the site log book. It is anticipated that for the first several days, the air samples will be delivered to TestAmerica on a daily basis and analyzed on a fast-turnaround basis. If analytical results indicate that dust suppression activities are adequate, air samples will continue to be collected but will be archived and only analyzed upon the specific request of the FOSC.

4.4 Small Tailings Pile Sampling

As part of the TCRA, the STP (OFS-002) will be relocated onto Iron King Mine property. The removal will be limited to the STP itself. The alluvial apron to the east of the STP will not be considered a part of the TCRA. The STP will be removed to a depth approximating the original grade, which will be determined visually in the field. Periodically as the STP material is removed, confirmation samples will be collected in the footprint of the removal. A sampling frequency of at least one composite sample for every 1000 square yards of surface area will be utilized. Each composite sample will be made up of five sample aliquots which will be chosen judgmentally with the goal of obtaining material representative of that 1000-square-yard portion of the footprint. Because the STP will only be removed to original grade, the confirmation sample results will only be used to document post-removal site conditions. The results will not be compared to the site-specific action levels for arsenic or lead.

4.5 Ambient Air Sampling

During earth-moving activities at residential locations, at least three air samples will be collected on a daily basis. The sampling strategy requires sample collection at locations upwind from the residential structures and downwind of the excavation location. The location upwind of excavation must also be sampled to determine the background contributions. It is anticipated that all but the first few days of air samples collected will be archived and only analyzed if needed.

Actual sampling locations will be determined daily based upon the wind direction and location of excavation.

5 Request for Analyses

Soil samples will be analyzed for lead and arsenic by U.S. EPA SW-846 Method 6010B. Borrow soil samples will be analyzed for RCRA 8 metals by U.S. EPA SW-846 Methods 6010B/7471A. Selected air samples will be analyzed for arsenic and lead by National Institute for Occupational Safety and Health (NIOSH) Method 7300. The remainder of the air samples will be archived for potential analysis.

5.1 Laboratory Analysis

TestAmerica Laboratory in Phoenix, Arizona will be used for all sample analyses. Sample containers, preservatives, and holding times, and the estimated number of samples including quality control (QC) samples are summarized in Table 5-1.

To provide analytical quality control for the analytical program, the following measures will be utilized:

- Additional sample volume will be collected for at least five percent of soil samples, to be utilized for matrix spike/matrix spike duplicate (MS/MSD) analysis.
- Duplicate soil samples will be collected from 10 percent of the sampling locations and submitted for soil analysis as “blind” duplicates. A duplicate soil sample will be prepared by collecting a double-volume of soil into a plastic baggie, homogenizing the contents, and then splitting the soil between two sample jars.

For air samples, duplicates and spike samples cannot be collected. A method blank air sample cassette will be submitted with the regular air samples at a frequency of approximately five percent (1 in 20) (see Section 6.3).

Table 5-1 Assessment Sampling and Analysis Summary Iron King Mine – Humboldt Smelter Yavapai County, Arizona		
E & E Project No. 002693.2110.01RA		TDD No. TO2-09-10-09-0004
Method	Lead, Arsenic, and RCRA 8 Metals by U.S. EPA Methods 6010B/7471A	Lead and Arsenic by NIOSH Method 7300
Sample Container	4-ounce glass jar	37-mm MCE cassette
Preservation	none	none
Analysis Holding Time	6 months*	6 months
Estimated Number of Unique Composite Samples	100	N/A
Estimated Number of Unique Discrete Samples	0	120
Estimated Number of Split Duplicate Samples	10	N/A
Minimum Total Site Sample Analyses	110	120
Matrix Spike/Matrix Spike Duplicates	1 per 20 samples (1) Submit one 4-ounce glass jar	N/A
Equipment Rinse Blanks (if non-dedicated equipment is used)		
Sample Container	500 milliliter plastic bottle	N/A
Preservation	HNO ₃	N/A
Analysis Holding Time	14 days	N/A
Number of Samples	1 per day	N/A
*the holding time for mercury is 28 days MCE = Mixed Cellulose Ester mm = millimeter NIOSH = National Institute for Occupational Safety and Health		

6 Field Methods and Procedures

6.1 Field Procedures

The following sections describe the field procedures and equipment that will be used during the site activities.

6.1.1 Standard Operating Procedures and Equipment

The equipment listed below may be utilized to obtain environmental samples from the respective media in accordance with the following sampling standard operating procedures (SOPs) or their equivalent:

- Environmental Response Team SOP #2012 Soil Sampling
- Ecology and Environment Inc. SOP # ENV 3.13: Soil Sampling
- Ecology and Environment Inc. SOP# ENV 3.15: Sampling Equipment Decontamination

The following is a partial list of equipment that is anticipated to come in contact with samples:

- Trowels or scoops
- Stainless steel buckets or glass containers
- Dedicated plastic baggies and disposable trowels

6.1.2 Equipment Maintenance

Field instrumentation for the collection of soil samples will be operated, calibrated, and maintained by the sampling team in accordance with the SOPs listed in Section 6.1.1 or their equivalent. Field instrumentation utilized for health and safety purposes will be operated, calibrated, and maintained by the sampling team according to the manufacturer's instruction. Calibration and field use data will be recorded in the instrument log books.

6.1.3 Inspection/Acceptance Requirements for Supplies and Consumables

There are no project-specific inspection/acceptance criteria for supplies and consumables. It is standard operating procedure that personnel will not use broken or defective materials; items will not be used past their expiration date; supplies and consumables will be checked against order and packing slips to verify the correct items were received; and the supplier will be notified of any missing or damaged items.

6.1.4 Logbooks

Field logbooks will document where, when, how, and from whom any vital project information was obtained. Logbook entries will be complete and accurate enough to permit reconstruction of field activities. A separate logbook will be maintained for each project. Logbooks are bound with consecutively numbered pages. Each page will be dated and the time of entry noted in military time. All entries will be legible, written in ink, and signed by the individual making the entries. Language will be factual, objective, and free of personal opinions. The following information will be recorded, if applicable, during the collection of each sample:

- Sample location and description
- Site sketch showing sample location and measured distances
- Sampler's name(s)
- Date and time of sample collection
- Type of sample (matrix)
- Type of sampling equipment used
- Onsite measurement data (e.g., temperature, pH, conductivity)
- Field observations and details important to analysis or integrity of samples (rain, odors, etc.)
- Type(s) of preservation used
- Field instrument reading (such as dust meter readings for health and safety purposes, etc.)
- Shipping arrangements (air bill numbers)
- Receiving laboratory(ies)

Several START team members may be on site performing different duties related to sample collection, processing, and analysis. If more than one sampling team is used, individual logbooks will be maintained for each sampling team. Each logbook will document the information relevant to the site activity, and at a minimum will include:

- Team members and their responsibilities
- Time of activities
- Deviations from sampling plans, site safety plans, and SAP procedures
- Levels of safety protection
- Calibration information
- Analytical data

6.1.5 Photographs

Photographs will be taken at representative sampling locations and at other areas of interest on site. They will serve to document field operations. When a photograph is taken, the following information will be written in the logbook or will be recorded in a separate field photography log:

- Time, date, location, and, if appropriate, weather conditions
- Description of the subject photographed
- Name of person taking the photograph

6.1.6 Electronic Sample Logging

The sampling team may utilize field management software to prepare sample labels and chain-of-custody forms.

The following information should be entered for each sample after collection:

- Sample name
- Sample date and time
- Number of sample bottles
- Type of preservation
- Analyses

In addition to these items, the software may also be used to keep track of other information such as sample depth, field measurements, and split samples.

The field team will generate chain-of-custody forms for each cooler of samples packaged and sent to a laboratory. Each chain-of-custody form will refer to the shipping method and tracking number. Printed chain-of-custody forms will be submitted to the laboratory with the samples.

The use of field management software will require that the field team have access to a computer, a printer, computer paper, and labels while in the field. Field team members will have received specific training in use of the software.

6.1.7 Mapping Equipment

Sample points and site features will be located and documented with a GPS unit. The GPS will be used to assign precise geographic coordinates to sample locations on the site. GPS mapping will be done by personnel trained in the use of the equipment and will be completed in accordance with the manufacturer's instructions. Expected output from the use of GPS mapping will be site maps with sample locations and major site features.

6.2 Soil Sampling Procedures

All sample locations will be recorded in the field logbook as sampling is completed. Each field sampling team will document each individual sampling location in a field logbook, which will include: the site address, area sample was collected with a quick representative sketch of the area, photographs taken, date, time, and sampling team members.

6.2.1 Discrete Sampling

Discrete sampling methodology is not anticipated for the work described in this SAP.

6.2.2 Composite Sampling**6.2.2.1 Borrow Material Sampling**

Five-point composite samples will be collected from borrow sources. One composite sample will be collected for each separate area within a borrow source from which soil may be used for fill material. Composite sample aliquots will be collected from 0 to 6 inches into the soil. The collection points for the sample aliquots will be uniformly spatially distributed over the area.

The composite sample aliquots will be collected into a plastic baggie; homogenized; and then transferred into a four-ounce glass jar. Additional borrow samples will be collected from each source at a rate of one for approximately every 300 cubic yards of soil removed. Borrow material will not be used for backfill until analytical results have documented that arsenic and lead concentrations are below the action levels.

6.2.2.2 Pre-Excavation Soil Sampling

At the FOSC's discretion, some properties may be "potholed" to one-foot or two-foot depths to collect five-point composite samples. One set of five-point composite samples would be collected for each quadrant of a property's yard (front, back, and side yards). The analytical results would provide the removal contractor with information regarding whether they will ultimately need to excavate to two feet bgs.

The collection points for the composite sample aliquots will be uniformly spatially-distributed within each area. A dedicated sampling spoon will be used to collect each composite sample. The composite sample aliquots will be collected into a plastic baggie; homogenized; and then transferred into a four-ounce glass jar.

6.2.2.3 Post-Excavation Soil Sampling

After an area has been excavated to an approximate depth of one-foot depth bgs, following guidelines in the Lead Handbook, the START will then collect one five-point composite sample from each front, back, and side yard. This procedure will also be used for individual hot spot removals. If samples from any area (front, back, side yard, or hot spot) exceed the action levels for arsenic and/or lead, another one-foot lift will be removed in that area and another composite sample will be collected. Soil removal will not exceed a two-foot bgs depth. As described in Section 4.3, the one-foot depth sampling interval may be by-passed in certain situations

The collection points for the composite sample aliquots will be uniformly spatially-distributed within each area. Each sample aliquot will be collected from 0 to 2 inches bgs. A dedicated sampling spoon will be used to collect each composite sample. The composite sample aliquots will be collected into a plastic baggie; homogenized; and then transferred into a four-ounce glass jar.

6.3 Air Sampling Procedures

The air samples collected during this project will be used to document arsenic and lead concentrations in air during the removal activities. Air samples will be analyzed only for the first several days of removal operations. The quick-turnaround results will be reviewed to determine whether the START's real-time air monitoring protocol for total particulates is effectively controlling fugitive dust emissions during removal operations. Air samples will continue to be collected on a daily basis, but will be archived in sealed and labeled boxes that will be kept with the project files.

Air samples will be collected using NIOSH Method 7300. Mixed cellulose ester (MCE) sample cassettes of 37-millimeter diameter and 0.8 micrometer pore size will be used to collect the sample. A low flow (2 to 3 liters per minute) air sampling pump will be used to draw ambient



6. Field Methods and Procedures

air into the sample cassette. At least three air samples will be collected from locations spatially distributed about the removal area, as described in Section 4.2.

The air sample will be collected using the following process:

- Uncap both ends of a new sample cassette and label it as a daily calibrator. Attach the cassette upstream of the sampling pump using tubing which comes with the pump. Make sure that the direction arrow on the cassette points in the direction of the air flow. Attach a pump calibrator to the exhaust of the pump.
- Turn on the pump, adjust the flow rate to 2 to 3 liters per minute, and log the exact flow rate on an air sampling form such as that which is presented in Figure 6-1.

Figure 6-1 Example Air Sampling Form

IRON KING MINE – HUMBOLDT SMELTER REMOVAL
DAILY AIR SAMPLING LOG SHEET

Date:

OFS-

Unit ID	Location	Time On	Time Off	Initial Flow Rate	Final Flow Rate	Average Flow Rate	Total Volume

- Turn off the pump, remove the calibrator, place the pump at the sampling location, and attach a new, labeled sample cassette. Do not uncap the upstream side of the cassette until ready to start the pump.
- Turn on the pump and log the time the pump was turned on.
- At the end of the work day, place the calibrator on the exhaust of the pump and note the flow rate.
- Turn off the pump and note the time the pump was turned off.
- Remove the sample cassette, cap both ends, and package it in a plastic baggie for archive or shipment to the laboratory.
- Determine the average flow rate for the sample by adding the beginning flow rate and ending flow rate together and dividing by two.
- Determine the volume of air (in liters) that flowed through the sample by multiplying the flow rate by the sampling time (in minutes).
- Write the volume of air which flowed through the sample on the chain of custody form, along with the sample identifier.

A weather station will be set up near the removal area to record wind direction and velocity continuously during removal operations. The weather station data will be downloaded and archived on a daily basis.

7 Disposal of Investigation-Derived Waste

In the process of collecting environmental samples at this site, several different types of potentially-contaminated investigation-derived wastes (IDW) will be generated:

- Used personal protective equipment (PPE)
- Disposable sampling equipment
- Decontamination fluids
- Extra sample soil remaining in plastic baggies

The U.S. EPA's National Contingency Plan requires that management of IDW generated during site investigations comply with all relevant or appropriate requirements to the extent practicable. This sampling plan will follow the Office of Emergency and Remedial Response Directive 9345.3-02 (May 1991), which provides the guidance for management of IDW during site investigations. Listed below are the procedures that will be followed for handling IDW. The procedures are flexible enough to allow the site investigation team to use its professional judgment on the proper method for the disposal of each type of IDW generated at each sampling location.

- Used PPE and disposable sampling equipment will be double-bagged in plastic trash bags and disposed of in a municipal refuse dumpster. These wastes are not considered hazardous and can be sent to a municipal landfill. Any PPE or dedicated equipment that is to be disposed of that can still be reused will be rendered inoperable before disposal.
- Decontamination fluids, if any, will consist of water with residual contaminants and/or non-phosphate detergent. These fluids will be poured onto removed, contaminated soil which will then be transported for stockpiling at the Iron King Mine.
- Extra sample soil remaining in plastic baggies will be placed with removed, contaminated soil which will then be transported for stockpiling at the Iron King Mine.

8 Sample Identification, Documentation and Shipment

8.1 Sample Nomenclature

A unique, identifiable name will be assigned to each sample. Samples will have a prefix indicating the project: IKMHSR (Iron King Mine – Humboldt Smelter Removal), followed by and identifier of the property from which they were collected (e.g., OFS-133). The property identifier will be followed by a sequential number starting with 01 corresponding to the sample number from that particular property. The sample identifier will be followed by a number indicating depth (002 represents 2 inches bgs). Equipment rinsate blank samples will be designated as Metals-EB-(type of equipment [e.g., trowel])-date.

Air samples will be designated by IKMHSR-Date-Air-#, where # will be the air sampling station number (1, 2, or 3).

Field duplicate samples will have a fictitious sample identifier, which will be noted in the logbook. A summary of this sample naming system is shown in Table 8-1.

Table 8-1 Soil Sample Numbering System Iron King Mine – Humboldt Smelter Yavapai County, Arizona		
E & E Project No. 002693.2155.01RF		TDD No. TO2-09-11-08-0005
Type of Sample	Site Area	Sample ID
Primary Field Sample <u>Example:</u> Surface soil sample from side yard of OFS-133	Decision Unit Area	IKMHSR-<OFS number>-<sequential number starting with 1>-<depth in inches>-<composite or aliquot if applicable> IKMHSR-OFS-133-002-002
Field Duplicate <u>Example:</u> Duplicate soil sample from side yard of OFS-133	All	IKMHSR-<OFS number>-<fictitious number>-<depth in inches> IKMHSR-OFS-133-007-002

2011 ecology & environment, inc.

8.2 Container, Preservation, and Holding Time Requirements

All sample containers will have been delivered to the START in a pre-cleaned condition. Container, preservation, and holding time requirements are summarized in Table 5-1.

8. Sample Identification, Documentation and Shipment

8.3 Sample Labeling, Packaging, and Shipping

All samples collected will be labeled in a clear and precise way for proper identification in the field and for tracking in the laboratory. Sample labels will be affixed to the sample containers and will contain the following information:

- Sample number
- Date and time of collection
- Site name
- Analytical parameter and method of preservation

Samples will be stored in a secure location on site pending delivery to the laboratory. Sample coolers will be retained in the custody of site personnel at all times or secured so as to deny access to anyone else.

The procedures for shipping soil samples are:

- If ice is used then it will be packed in double zip-lock plastic bags.
- The drain plug of the cooler will be sealed with tape to prevent melting ice from leaking.
- The bottom of the cooler will be lined with bubble wrap to prevent breakage during shipment.
- Screw caps will be checked for tightness.
- Containers will have custody seals affixed so as to prevent opening of the container without breaking the seal.
- All glass sample containers will be wrapped in bubble wrap.
- All containers will be sealed in zip-lock plastic bags.

All samples will be placed in coolers with the appropriate chain-of-custody forms. All forms will be enclosed in plastic bags and affixed to the underside of the cooler lid. If samples require refrigeration during shipment then bags of ice will be placed on top of and around samples. Empty space in the cooler will be filled with bubble wrap or Styrofoam peanuts to prevent movement and breakage during shipment. Each ice chest will be securely taped shut with strapping tape, and custody seals will be affixed to the front, right, and back of each cooler.

Samples will be shipped for immediate delivery to the contracted laboratory. Upon shipping, the laboratory will be notified of:

- Sampling contractor's name.
- The name of the site.
- Shipment date and expected delivery date.
- Total number of samples, by matrix and the relative level of contamination for each sample (i.e., low, medium, or high).

8. Sample Identification, Documentation and Shipment

- Carrier; air bill number(s), method of shipment (e.g., priority).
- Irregularities or anticipated problems associated with the samples.
- Whether additional samples will be sent; whether this is the last shipment.

8.4 Chain-of-Custody Forms and QA/QC Summary Forms

A chain-of-custody form will be maintained for all samples to be submitted for analysis, from the time the sample is collected until its final disposition. Every transfer of custody must be noted and a signature affixed. Corrections on sample paperwork will be made by drawing a single line through the mistake and initialing and dating the change. The correct information will be entered above, below, or after the mistake. When samples are not under the direct control of the individual responsible for them, they must be stored in a container sealed with a custody seal. The chain-of-custody form must include the following:

- Sample identification numbers
- Identification of sample to be used for MS/MSD purposes
- Site name
- Sample date
- Number and volume of sample containers
- Required analyses
- Signature and name of samplers
- Signature(s) of any individual(s) with control over samples
- Note(s) indicating special holding times and/or detection limits

The chain-of-custody form will be completed and sent with the samples for each laboratory and each shipment. Each sample cooler should contain a chain-of-custody form for all samples within the sample cooler.

A QA/QC sample summary form will be completed for each method and each matrix of the sampling event. The sample number for all blanks, reference samples, laboratory QC samples (MS/MSDs), and duplicates will be documented on this form. This form is not sent to the laboratory. The original form will be sent to the reviewer who is validating and evaluating the data; a photocopy of the original will be made for the project manager master file.

9 Quality Assurance and Control (QA/QC)

9.1 Field Quality Control Samples

The QA/QC samples described in the following subsections, which are also listed in Table 5-1, will be collected during this investigation.

9.1.1 Assessment of Field Contamination (Blanks)

9.1.1.1 Equipment Blank Samples

Dedicated sampling equipment will be used. However, if non-dedicated equipment, such as stainless steel trowels or hand augers, is used to collect samples, equipment rinsate blanks will be collected at a rate of one per day to evaluate field sampling and decontamination procedures.

9.1.1.2 Field Blanks

Field blanks will be collected for air samples, only. They will consist of sample cassettes from the same sample batch as the real samples. The “blank” cassette will be left un-capped during the day of sampling, then capped and submitted to the laboratory with the regular samples. The blank results will be used to evaluate whether contaminants have been introduced into the samples through a means other than the sampling pump.

9.1.2 Assessment of Sample Variability (Field Duplicate or Co-located Samples)

Duplicate soil samples will be collected at selected sample locations. These locations will be chosen randomly in the field based on field observations and will be collected at a rate of approximately one for every 10 field samples.

9.1.3 Laboratory Quality Control (QC) Samples for Soil

A laboratory QC sample, also referred to as a MS/MSD, is not an extra sample; rather, it is a sample that requires additional QC analyses and therefore may require a larger sample volume. The chain-of-custody records for these samples will identify them as laboratory QC samples. The samples selected for laboratory QC will be selected at random. A minimum of one laboratory QC sample will be submitted per 20 samples (or one per delivery group), per matrix, to be analyzed for each analytical parameter. If the DQIs for analytical parameters are not achieved, further data review will be conducted to assess the impact on data quality.

Additional sample volume will be submitted for all lead and arsenic samples designated as laboratory QC samples and will be designated as MS/MSD samples on the chain-of-custody to the fixed-base laboratory.

9.2 Analytical and Data Package Requirements

It is required that all samples be analyzed in accordance with the U.S. EPA Method listed in Table 5-1. The laboratory is required to supply documentation to demonstrate that their data meet the requirements specified in the method. A preliminary data summary is expected within 20 working days after submission of samples for analysis. A full validation data package will be required five weeks after submission of samples. The laboratory will also provide all data electronically in a Microsoft Excel-compatible format or delimited text file.

Deliverables for this project must meet the guidelines in *Laboratory Documentation Requirements for Data Evaluation* (EPA Region IX R9/QA/00.4.1, March 2001). The following deliverables are required. Note that the following data requirements are included to specify and emphasize general documentation requirements and are not intended to supersede or change requirements of each method.

- A copy of the chain-of-custody, sample log-in records, and a case narrative describing the analyses and methods used.
- Analytical data (results) for up to three significant figures for all samples, method blanks, MS/MSD, Laboratory Control Samples (LCS), duplicates, Performance Evaluation samples (if applicable), and field QC samples.
- QC summary sheets/forms that summarize the following:
 - MS/MSD/LCS recovery summary
 - Method/preparation blank summary
 - Initial and continuing calibration summary (including retention time windows)
 - Sample holding time and analytical sequence (i.e., extraction and analysis)
 - Calibration curves and correlation coefficients
 - Duplicate summary
 - Detection limit information
- Analyst bench records describing dilution, sample weight, percent moisture (solids), sample size, sample extraction and cleanup, final extract volumes, and amount injected.
- Standard preparation logs, including certificates of analysis for stock standards.
- Detailed explanation of the quantitation and identification procedure used for specific analyses, giving examples of calculations from the raw data.
- The final deliverable report consisting of sequentially numbered pages.

9.3 Data Management

Samples will be collected and described in a logbook, as discussed in Section 6.1.4. Samples will be kept secure in the custody of the sampler at all times; the sampler will ensure that all preservation parameters are being followed. All samples that are to be sent to the off site analytical laboratory will be collected and logged on chain-of-custody forms as discussed in

Section 8.4. A START member will only submit samples to the analytical laboratory with chain-of-custody documentation. All submitted samples will be in a properly custody-sealed container. Specifics are discussed in Section 8.3. The laboratories will note any evidence of tampering upon receipt.

All data summary reports and complete data packages will be archived by the project manager. The data validation reports and laboratory data summary reports will be included in the final report to be submitted to the EPA.

9.4 Data Validation

Data validation of all data will be performed by the START or their subcontractor in accordance with U.S. EPA Region IX Superfund Data Evaluation/Validation Guidance R9QA/006.1, December 2001.

The standard data quality review requirements of a Tier 2 validation of 100 percent of the data (as defined in the U.S. EPA document, *Requirements for Quality Assurance Project Plans*, March 2001) will satisfy the data quality requirements for this project. Upon completion of validation, data will be classified as one of the following: acceptable for use without qualifications, acceptable for use with qualifications, or unacceptable for use.

If during or after the evaluation of the project's analytical data it is found that the data contain excess QA/QC problems or if the data do not meet the DQI goals, then the independent reviewer may determine that additional data evaluation is necessary. Additional evaluation may include U.S. EPA Region IX Superfund Data Evaluation/Validation Guidance R9QA/006.1 for evaluation Tier 3.

To meet evaluation and project requirements, the following criteria will be evaluated during a Tier 2 evaluation:

- Data package completeness
- Laboratory QA/QC summaries
- Holding times
- Blank contamination
- Matrix related recoveries
- Field duplicates
- Random data checks
- Preservation and holding times
- Initial and continuing calibration
- Blank analyses
- Interference check samples

- Laboratory control samples
- Duplicate sample analysis
- Matrix spike sample analyses
- Sample serial dilution
- Field duplicate/replicate
- Overall assessment of data.

Upon completion of evaluation, an analytical data evaluation Tier 2 review report will be delivered to the project manager, and the data will be classified within the report as one of the following:

- acceptable for use without qualifications
- acceptable for use with qualifications
- unacceptable for use

The data with applicable qualifications will be attached to the report. Unacceptable data may be more thoroughly examined to determine whether corrective action could mitigate data usability.

9.5 Field Variances

As conditions in the field may vary, it may become necessary to implement minor modifications to this plan. When appropriate, the START QA Coordinator and U.S. EPA FOOSC will be notified of the modifications and a verbal approval obtained before implementing the modifications. Modifications to the original plan will be recorded in site records and documented in the final report.

9.6 Assessment of Project Activities

9.6.1 Assessment Activities

The following assessment activities will be performed by the START:

- All project deliverables (SAP, Data Summaries, Data Validation Reports, Investigation Report) will be peer reviewed prior to submission to the U.S. EPA. In time critical situations, the peer review may be concurrent with the release of a draft document to the U.S. EPA. Errors discovered in the peer review process will be reported by the reviewer to the originator of the document, who will be responsible for corrective action.
- The QA Coordinator will review project documentation (logbooks, chain-of-custody forms, etc.) to ensure the SAP was followed and that sampling activities were adequately documented. The QA Coordinator will document deficiencies, and the PM will be responsible for corrective actions.

9.6.2 Project Status Reports to Management

It is standard procedure for the START PM to report to the U.S. EPA Task Monitor (TM) any issues, as they occur, that arise during the course of the project that could affect data quality, data use objectives, the project objectives, or project schedules.

As requested, the START will provide XRF results to the U.S. EPA TM daily and unvalidated data will be provided as the data are received from the laboratory.

9.6.3 Reconciliation of Data with DQOs

Assessment of data quality is an ongoing activity throughout all phases of a project. The following outlines the methods to be used by the START for evaluating the results obtained from the project.

Review of the DQO outputs and the sampling design will be conducted by the START QA Coordinator prior to sampling activities. The reviewer will submit comments to the START PM for action, comment, or clarification. This process will be iterative.

A preliminary data review will be conducted by the START. The purpose of this review is to look for problems or anomalies in the implementation of the sample collection and analysis procedures and to examine QC data for information to verify assumptions underlying the DQOs and the SAP. When appropriate to sample design, basic statistical quantities will be calculated and the data will be graphically represented. When appropriate to the sample design and if specifically tasked to do so by the U.S. EPA TM, the START will select a statistical hypothesis test and identify assumptions underlying the test.

10 References

- EA Engineering, Science and Technology, Inc. (EA), 2010. *Remedial Investigation Report Addendum, Iron King Mine – Humboldt Smelter Superfund Site, Dewey-Humboldt, Yavapai County, Arizona*. March.
- EA, 2011. *Remedial Investigation Report Addendum, Iron King Mine – Humboldt Smelter Superfund Site, Dewey-Humboldt, Yavapai County, Arizona*. February.
- Ecology and Environment, Inc. (E & E), 2005. *Iron King Mine Site, Humboldt, Arizona, Draft Final Report*. October.
- U.S. Environmental Protection Agency (EPA), 1990. *Quality Assurance/Quality Control Guidance for Removal Activities, Sampling QA/QC Plan and Data Validation Procedures*.
- EPA, 1991. *Management of Investigation-Derived Wastes During Site Inspections*, Office of Emergency and Remedial Response, OERR Directive 9345.3-02, May.
- EPA, 2001. *U.S. EPA Region IX Superfund Data Evaluation/Validation Guidance R9QA/006*
- EPA, 2001. *Laboratory Documentation Requirements for Data Evaluation* (EPA Region IX R9/QA/00.4.1), March.
- EPA, 2001. *Requirements for Quality Assurance Project Plans* (EPA QA/R 5, EPA/240/B 01/003), March.
- EPA, 2002. *Guidance on Choosing a Sampling Design for Environmental Data Collection* (EPA QA/G 5S, EPA/240/R 02/005), December.
- EPA, 2003. *Superfund Lead-Contaminated Residential Sites Handbook* (OSWER Directive 9285.7-90), August.
2004. “USEPA Contract Laboratory Program, National Functional Guidelines for Inorganic Data Review, USEPA-540-R-04-004. October.
- EPA, 2005. *Uniform Federal Policy for Implementing Environmental Quality System* (EPA/505/F-03/001), March.
- EPA, 2006. *Guidance on Systematic Planning Using the Data Quality Objectives Process* (EPA/240/B-06/001), February.
- EPA, 2009. *Regional Screening Levels for Chemical Contaminants at Superfund Sites*, December.



A Data Quality Objective Process Document

Iron King Mine – Humboldt Smelter Removal

Data Quality Objectives (DQO) Process Document Objective Outputs

Contract: EP-S5-08-01
TDD No.: TO2-09-11-08-0005
Job No.: 002693.2155.01RF

In August 2011, the United States Environmental Protection Agency (U.S. EPA) Region IX Emergency Response Section's Superfund Technical Assessment and Response Team (START) Project Officer directed the Ecology and Environment, Inc. START to support a U.S. EPA-funded removal of contaminated soils at residential parcels in the town of Dewey-Humboldt, Arizona. To support the U.S. EPA's environmental data collection activities, the START has developed these project data quality objectives (DQOs), which will be used to develop the Iron King Mine – Humboldt Smelter Removal Sampling and Analysis Plan (SAP). These DQOs are included as Appendix B of the SAP.

1. THE PROBLEM

Background:

Previous U.S. EPA investigations, including an assessment conducted by the START in 2010-2011, have identified elevated arsenic and lead concentrations in surface and near-surface soils at residential properties located between the Iron King Mine and the Humboldt Smelter. The START assessment report (August 2011) determined that 13 of the properties should undergo partial- or full-property removals of contaminated soil, to a depth of up to 2 feet below ground surface (bgs). The 13 properties are listed in Table 2-1 of the SAP.

Conceptual Site Model:

- The media of concern is surface- and near-surface soil.
- The contaminants of potential concern are arsenic and lead.
- The soil at the site was potentially contaminated with arsenic and lead due to wind dispersion from the mine and/or smelter and from possible train load-out operations from the smelter.
- The release of arsenic and lead at the site has impacted shallow soils at some residential properties.

Exposure Scenario:

Current Conditions

- Concerns based on current conditions include: 1) direct exposure of human and/or environmental receptors to arsenic and lead in soils.

Removal Action Conditions

- The conditions at the site during the removal action may pose an additional threat to human health and the environment. Direct exposure of human and/or environmental receptors to arsenic and lead-contaminated soils is of concern during a removal.

- Soils removed from the site may also pose a threat to human health during transportation and disposal.

Post Removal

Removal of arsenic- and lead-containing soils at the 13 properties will significantly alleviate the potential for human and/or environmental exposure to arsenic and lead.

Planning Team:

Mr. Craig Benson, U.S. EPA Federal On-Scene Coordinator (FOSC)
 Mr. Howard Edwards, START Quality Assurance Officer
 Mr. Michael Schwennesen, START Project Manager
 Analytical Laboratory – TestAmerica Laboratory in Phoenix, Arizona.

The Roles and Responsibilities for this investigation are as follows:

- **Craig Benson, U.S. EPA FOSC**, will be the primary decision-maker and will direct the project, specify tasks, and ensure that the project is proceeding on schedule and within budget. Additional duties include coordination of all preliminary and final reporting and communication with the START Project Manager.
- **Howard Edwards, START Quality Assurance Officer**, will provide quality assurance oversight to ensure that planning and plan implementation are in accordance with U.S. EPA regional quality assurance/quality control (QA/QC) protocol. He will provide technical direction concerning QA/QC as needed to the U.S. EPA FOSC and the START project manager.
- **Michael Schwennesen, START Project Manager**, will coordinate with the planning team to develop objectives and complete an approved SAP. The START Project Manager will have the responsibility for implementation of the SAP, coordination of project tasks, coordination of field sampling, project management, and completion of all preliminary and final reporting.

Available Resources:

The current START budget for environmental data collection and reporting is \$127,800, which includes activities related to the planning, sampling, laboratory analysis, data evaluation, and reporting for the Iron King Mine - Humboldt Smelter Removal (IKMHSR).

Other Considerations and Constraints Related to Problem and Resources:

- Removal activities will begin on September 12, 2011. START support will be required throughout the project which is expected to take up to two months.
- Fast-turnaround analytical results will be required so that removal and backfill operations are not impaired.

2. THE DECISION

Primary and Secondary Study Questions:

Primary Study Question #1: What is the lateral and vertical extent of arsenic and lead-contaminated soils in the area of concern (garden area) that exceed the site screening levels?

Secondary Study Question #1: Do soils in additional areas of concern at the site (as identified by site observations or aerial photographs) contain arsenic and lead at concentrations that exceed the site

screening levels?

Primary Study Question #2: Does groundwater at the site contain arsenic and lead at concentrations that exceed the site screening levels?

Actions that could Result from Resolution of the Study Questions:

For Primary and Secondary Study Questions #1:

If it is resolved that the lateral and/or vertical extent of arsenic and lead contamination in the garden area has not been defined, then further assessment to delineate extent may be initiated.

If it is resolved that the lateral and/or vertical extent of arsenic and lead contamination in the garden area has been defined, then no further delineation will be required.

If the lateral and vertical extent of arsenic and lead contamination in the garden area is defined, the delineation will be used as a guide for planning future assessment or removal activities.

If it is resolved that the arsenic and lead concentrations in soil in a sampling location in a specific area of concern at the site do not exceed any screening level, then the information may be used to support a determination that no further action is needed for that area of the site.

If it is resolved that the soil in a sampling location in a specific area of concern at the site contains arsenic and lead at concentrations that exceed screening levels, then further assessment and/or actions may be warranted in that area of the site.

For Primary Study Question #2:

If it is resolved that arsenic and lead in groundwater does not exceed any screening level, then the information may be used to support a determination that no further action is needed.

If it is resolved that arsenic and lead in groundwater is present at concentrations that exceed screening levels, then further assessment may be warranted.

Decision Statement(s):

Soil analytical data will be used to evaluate the lateral and vertical extent of arsenic and lead at concentrations above screening levels in the garden area soils at the site. Soil analytical data will also be used to evaluate if arsenic and lead is present in soil at concentrations above screening levels in specific areas of concern at the site. Groundwater analytical data will be used to evaluate if arsenic and lead is present in groundwater at concentrations above screening levels at the site.

- The location and extent of soils at the site containing arsenic and lead at concentrations that exceed site screening levels will be determined in order to assist the U.S. EPA in establishing the need to conduct further assessment or actions.
- The presence of groundwater at the site containing arsenic and lead at concentrations that exceed site screening levels will be determined in order to assist the U.S. EPA in establishing the need to conduct further assessment.

3. DECISION INPUTS

Sources of Information Currently Available:

- Surface and shallow soil data collected during U.S. EPA/START December 2010 sampling event (see Appendix A of the SAP).

New Environmental Data Required to Resolve the Decision Statements:

- Definitive analytical data for arsenic and lead at the site (between 0 and 20 feet below ground surface [bgs], to a maximum of approximately 50 feet bgs).
- Physical site data such as observations of soil types beneath the site.
- Definitive analytical data for arsenic and lead in groundwater beneath the site.
- Geospatial (location) data for the area and sampling locations.

Sources of Information to Resolve the Decision Statements:

- Analytical data from proposed sampling.
- Global Positioning System (GPS) location data from proposed sampling.

Information Needed to Establish Site Screening Level:

Potential screening levels for COPCs may come from the following sources:

- U.S. EPA Region 9 RSLs for Residential Soil (November, 2010).
- California EPA Office of Environmental Health Hazard Assessment (OEHHA) maximum contaminant levels (MCLs)/Public Health Goals (PHGs).

Measurement Methods:

Collected soil and groundwater samples can be definitively analyzed to determine arsenic and lead concentrations by the U.S. EPA methods as follows:

- Arsenic and lead by U.S. EPA Method 314.0.

Confirm that Appropriate (Analytical) Methods Exist to Provide the Necessary Data:

All indicated definitive methods have sufficient sensitivity, accuracy, precision, and other quality parameters to generate necessary data. See Table 3-1 of the SAP for additional information.

4. DEFINE THE STUDY BOUNDARIES

Specific Characteristics that Define Population Being Studied:

- The spatial distribution of arsenic and lead in soils within the specified spatial and temporal boundaries.
- The arsenic and lead concentrations in soils within the specified spatial and temporal boundaries.
- The arsenic and lead concentrations in groundwater within the specific spatial and temporal boundaries.

Spatial Boundaries:

The investigation boundaries will be the property boundaries of the northwestern-most of the four 5-acre parcels (APN 0425-091-21-0-000), with potential extension of the spatial boundaries to include the other three 5-acre parcels depending on site observations. The boundary will encompass the specified area to a depth of approximately 50 feet bgs, the deepest depth at which first encountered groundwater is anticipated.

Temporal Boundaries:

The decisions will apply to determinations of risk associated with long-term direct exposure to contaminated soils as well as potential future migration to groundwater. However, the decision may also apply to short-term (acute) exposure during potential future removal activities.

Arsenic and leads are environmentally persistent, and arsenic and lead salts are readily soluble in water. Arsenic and lead is also a widespread contaminant in drinking water in the State of California.

The timeframe of the planned assessment is as follows:

- The SAP will be submitted to the U.S. EPA by March 14, 2011.
- Sample collection will take place beginning March 21, 2011.
- Preliminary analytical data will be reported to START approximately three weeks after sample delivery to the laboratory.
- Data packages and final data should be reported to project management approximately 5 weeks after sample delivery to the laboratory.

Practical Constraints on Data Collection:

Physical Constraints:

- The two structures on the property may prevent delineation to the east and south of the area of concern.
- Geoprobe refusal in the subsurface will limit the vertical extent of sampling. Repeated sampling attempts at locations near refusal locations will proceed within practical time and effort constraints.
- Groundwater and vadose zone soil sampling may be inhibited if groundwater is first encountered at a depth difficult to attain or through a soil type difficult to penetrate using a Geoprobe®. Groundwater has been estimated by the RWQCB to occur at depths between 25 and 50 feet bgs. Soil type is unknown.

Other Constraints on Data Collection

- The turnaround times on data are always estimated and cannot be assured. Sample and system problems may indiscriminately increase data turnaround times.

6. LIMITS ON DECISION ERRORS

Range of the Parameter(s) of Interest:

For all investigation areas and parameters, the range of interest for a COPC is from ½ the site screening level to anything above the site screening levels. Quantitatively precise and accurate determinations of contaminant concentrations that are significantly above (i.e., >100 times) the site screening level are not necessary.

Based upon previous investigations, soils containing arsenic and lead are expected to be present at the site at concentrations above site screening levels.

Baseline Condition (*The Null Hypothesis*):

The contaminant concentrations in soil and/or groundwater are equal to or greater than the site screening levels.

Alternative Condition (*The Alternative Hypothesis*):

The contaminant concentrations in soil and/or groundwater are less than site screening levels.

Decision Error

A discussion of decision error and decision error goals is presented in Tables 6-1 and 6-2.

TABLE 6-1 DECISION ERRORS
Soil and Groundwater
Mojave River Pyrotechnics Assessment

E & E Project No.: 002693.2124.01RA

TDD No.: TO2-09-10-12-0003

<u>Decision Error</u>	Deciding that an area is contaminated and requires restrictions, additional investigation, and mitigation when the site is not contaminated.	Deciding that an area is not contaminated and requires no restrictions, additional investigations or mitigation when the site is contaminated.
<u>True Nature of Decision Error</u>	The sample concentrations are either not representative or are biased high.	The sample concentrations are either not representative or are biased low.
<u>The Consequence of Error</u>	1) Development of the site will have restrictions and will undergo additional investigation or additional mitigating activities. These situations would cost additional resources of time, money, and manpower and could negatively impact the environment. This could limit use of the site.	1) Site occupants could be directly exposed to contaminants. 2) The COPCs in contaminated soil could potentially migrate throughout the area or migrate vertically to impact groundwater. 3) The COPCs in contaminated groundwater could continue to migrate and could potentially impact drinking water. 3) The contaminants could become more exposed and more accessible if the site is in use.
<u>Which Decision Error Has More Severe Consequences Near the Screening Level?</u>	<u>LESS SEVERE</u> To human health, but with appreciable economic consequences.	<u>MORE SEVERE</u> Since the contaminated soil may pose risks to human health and/or the environment.
<u>Error Type Based on Consequences</u>	<u>False Acceptance Decisions</u> A decision that the area is contaminated when it is not.	<u>False Rejection Decisions</u> A decision that the area is not contaminated when it is.
<u>Definitions</u> False Acceptance Decisions = A false acceptance decision error occurs when the null hypothesis is not rejected when it is false. False Rejection Decisions = A false rejection decision error occurs when the null hypothesis is rejected when it is true. <p style="text-align: right;">2011 ecology & environment, inc.</p>		

Because a judgmental sampling approach will be utilized for groundwater sampling and for a portion of the soil sampling, decision error limit goals were determined only for the systematic soil sampling in the garden area.

**TABLE 6-2 DECISION ERROR LIMIT GOALS
Soil – Garden Area
Mojave River Pyrotechnics Assessment**

E & E Project No.: 002693.2124.01RA

TDD No.: TO2-09-10-12-0003

True Average Concentration of Area (% of Screening Level [SL])	Decision Error	Typical Decision Error Probability Goals (Based on Professional Judgment)	Type of Decision Error
<75 %	A decision that a portion of the site is contaminated when it is not.	Less than 5 %	False Acceptance
75 to <100 % SL	A decision that a portion of the site is contaminated when it is not.	Gray Area ¹	False Acceptance
100 to 150 % SL	A decision that a portion of the site is not contaminated when it is.	10 % ²	False Rejection
> 150 %	A decision that a portion of the site is not contaminated when it is.	less than 1%	False Rejection

The goals in this table are based on professional judgment as relevant to the Soil Assessment.

¹ Gray Area is where relatively large decision errors are acceptable.

² Note that relatively large decision errors are expected when the true contaminant concentrations are between 100 and 150 % of the screening level. Decreasing the probability is not possible since sampling and analytical uncertainties and biases cannot be eliminated.

2011 ecology & environment, inc.

7. OPTIMIZED DESIGN FOR OBTAINING DATA

General:

All activities and documentation related to the project should proceed under a Quality Management Plan. All sampling, analytical, and quality assurance activities will proceed under a U.S. EPA-approved SAP. A record of sampling activities and deviation from the SAP must be documented in a bound field log book. Prior to sample collection, all project sampling personnel will review relevant sampling procedures and relevant QA/QC requirements for selected analytical methods.

Decision Error Minimization:

Average Concentrations

In order to minimize a decision error related to data uncertainty, the decision-maker should consider statistical evaluations of the data prior to making decisions.

Data from Individual Sample Locations

The decision-maker should consider data uncertainty when making decisions based upon sampling data and associated estimated values based upon a single location. An individual data value reported below the site screening level may potentially be biased low, while a data value reported above the site screening level may potentially be biased high. The probability of decision errors increases at COPC concentrations around the site screening level due to both data uncertainty and data bias.

For any reported values near the method detection limit, the uncertainty of any given value is even greater. Thus the probability of decision error is greatly increased at COPC concentrations near detection limits. The uncertainty for estimated data (i.e., data based on extrapolations and interpolations) is typically greater than for actual data. Therefore, the probability of decision errors is greatly increased for extrapolated data.

Due to the nature of the deposition of contamination, it is reasonable to assume that data from any individual sample locations on this site can represent a larger area. However, there are insufficient data to determine the confidence of any single sampling location. Thus the decision-maker should acknowledge that discrete data points could potentially not be representative of any greater area.

Contamination Distribution Map

Data from sampling locations can be used to create a contamination distribution map. The mapped contaminant concentrations indicated within an area should generally be based upon the sample data from that area and the sample data from adjacent locations (particularly if discrete sample data are being used). The generated map model could be used to estimate the concentrations of contamination throughout the property. The decision-maker should consider the data source and statistical sophistication of the distribution map prior to making decisions based upon the map.

Search Grid Size

Decision-makers should consider the sizes and probability of missing a contamination hot spot when evaluating sampling grid data.

Decision Error Limits

There are limited contaminant data available for the soils and groundwater at this site. Therefore, a sampling design constructed specifically to meet the decision error limits discussed in Step 6 is not possible. Data generated from this investigation may be used to determine whether decision error goals have been achieved.

Specific Design Optimization:

Based upon the project's goals and objectives, the Planning Team considered the following design elements as necessary to achieve the DQOs:

- The collection of soil samples for arsenic and lead analysis.
- The collection of groundwater samples for arsenic and lead analysis.
- Systematic soil sampling within the garden area.
- Biased judgmental soil sampling at individual locations of concern in other portions of the site selected based on visual observations.
- Judgmental groundwater sampling at locations distributed within the garden area.
- Generation of data that will indicate the geographical distribution of contamination (GPS data).

The objectives of the sampling are: 1) to evaluate arsenic and lead concentrations in soils within the garden area at the site; 2) to evaluate the lateral and vertical extent of arsenic and lead concentrations that exceed the screening level in soil within the garden area; 3) to evaluate arsenic and lead concentrations in soils at areas of concern in other portions of the site selected based on visual observations of historical aerial photographs; and 4) to evaluate arsenic and lead concentrations in groundwater beneath the garden area at the site.

The primary sampling area is the garden area located in the northwest corner of the northwest residential parcel of the site (APN 0425-091-21-0-000). During the December 2010 sampling, the garden area was the location of the surface and shallow subsurface soil samples in which elevated arsenic and lead concentrations were detected. Based on review of historical aerial photographs, additional sample areas were identified to the rear of this parcel as potential historical storage or unauthorized disposal areas. A subsurface geophysical survey will be conducted in the garden area and the potential historical storage areas prior to sampling to determine whether any anomalous subsurface features are present. Additionally, during the proposed March 2011 sampling event, the other three parcels that make up the site will be evaluated visually to identify any potential areas of concern. Potential areas of concern identified in the other three parcels may be selected for targeted geophysical surveys and potential subsequent soil sampling; however, a sampling plan has not been established as part of this SAP for the three remaining parcels.

In consultation with the U.S. EPA, a grid sampling design combined with judgmental sampling was selected to meet the specified DQOs. A rectangular grid of 20 soil boring locations was situated to cover the entire garden area, including the perimeters. Visual Sample Plan, Version 6.0 (Battelle Memorial Institute 2010) (VSP) was used to determine that the specified grid will detect a circular hotspot with a radius of at least 27 feet.

Three additional judgmental boring locations were selected, in consultation with the U.S. EPA, for locations in the southern half of the northwestern parcel. Based on review of historical aerial photographs, the northwestern and southeastern of the three biased sample locations are situated at either end of a visible pathway or trail that may have been used to traverse historical storage or disposal areas. The third biased sample location is located in an area that historical aerial photographs show to have been fenced at one time, possibly indicating a storage or disposal area. Proposed sampling locations are presented in Figure 4-1 of the SAP.

Four vertical soil samples per each of the 23 boring locations will be collected at 1 foot bgs (6 – 12 inches bgs), 3 feet bgs, 6 feet bgs, and 10 feet bgs. Based on field observations, up to five sample locations in the

garden area may be selected for additional sampling at 15 and 20 feet bgs. At three boring locations in the garden area grid, situated at the northwestern and southwestern corners and in the center of the eastern perimeter, groundwater samples will be collected. A fourth boring location may be added on the north side of Poplar Street, for collection of an additional groundwater sample. At these borings, soil samples will be collected to 20 feet bgs at the intervals described above; below 20 feet bgs, soil samples will be collected at 10-foot intervals to first encountered groundwater and will also be collected in the vadose zone immediately above first encountered groundwater. Groundwater is estimated to occur between 25 and 50 feet bgs.

An estimated 117 systematic and judgmental soil samples are proposed within the gridded garden area and at the three biased sample locations. Three groundwater samples are proposed within the garden area. Sample locations at the other three parcels that make up the site or across Poplar Street will not be collected without prior direction from the FOSC.

The following methods of soil and groundwater sampling may be used at the site:

- A Geoprobe® with Macrocore or Largebore sampling device will use direct push technology to advance the soil boring to the boring termination depth. During boring advancement, the Geoprobe® will collect soil cores in a polyethylene terephthalate glycol (PETG) sample liner in discrete intervals encompassing the target sampling depth. Soils will be transferred from the sample sleeve at the appropriate target depth to the appropriate container for transportation to the laboratory.
- A hand auger may be used to advance the boring to the desired depth in areas suspected of potential underground obstructions. After the hand auger is used to advance to the target sampling depth, the soils will be transferred from the auger to the appropriate sample containers.
- At the three boring locations selected for groundwater sampling, the Geoprobe® will be advanced to first encountered groundwater. Soils will be collected and observed during boring advancement to characterize lithology and to identify when groundwater is reached based on soil saturation. The boring will be terminated approximately 5 to 10 feet into groundwater. After withdrawing the Geoprobe® rods, a temporary groundwater well will be constructed using 3/4-inch diameter PVC casing riser connected to 5 to 10 feet of 0.010-inch slot PVC screen. A grab groundwater sample will be collected by lowering a bailer within the temporary well to the water level or by using tubing and valve to create a passive pumping system. The water sample will be transferred from the bailer or tubing to the appropriate sample container.

All samples will be placed in coolers and chilled with ice for storage and shipping. Duplicates, equipment blanks, and other appropriate QA/QC samples will be collected and are specified in the SAP. Data review, independent of the laboratory, will be performed on all analytical data that may be used in decision-making. The GPS coordinates (latitude and longitude) of each sampling location will be determined and documented during sampling.

If the initial sampling location is inaccessible or refusal is encountered, the boring will be moved several feet and a second attempt will be made. If a boring location was moved to an area that was not subject to a geophysical survey to identify subsurface features, the borehole will be hand augered to a depth of approximately 3 to 5 feet bgs prior to sampling using the Geoprobe®. The field sampling team will proceed to collect samples at a specific location within practical time and effort constraints.

Analysis:

All soil and groundwater samples collected will be analyzed for arsenic and lead by the following

definitive method:

- Arsenic and lead by U.S. EPA Method 314.0.

B Site Specific Health and Safety Plan



Title and Approval Sheet

U.S. EPA Region IX Emergency and Rapid Response Services Iron King Mine-Humboldt Smelter Site Dewey-Humboldt, Arizona

Health and Safety Plan
August 2011
Contract No. EP-W-07-022, ERRS IX
EPA Task Order No. 022-9098
EQ Project No. 030262.0098

Environmental Quality Management, Inc.
6825 216th Street SW, Suite J
Lynnwood, Washington, 98036

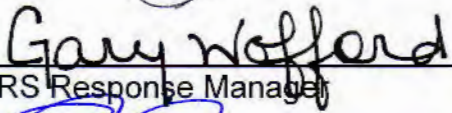
Approved: <u></u> On-Scene Coordinator, USEPA Region 9	Date: <u>9/2/11</u> 11-3-11
Approved: <u></u> ERRS Response Manager	Date: <u>6 SEPT 11</u>
Approved: <u></u> Program Manager	Date: <u>9/1/11</u>
Approved: <u></u> START Representative	Date: <u>9/12/11</u>

A. SITE INFORMATION, ROLES AND RESPONSIBILITIES

Site Name: Iron King Removal
Site Address: Dewey-Humboldt, Arizona (34° 31' 57.00" N 112° 15' 08.80" W)
Date of Activities: September 12-October 7, 2011
Participants: ☐ USEPA ☐ START ☐ ERRS PST Other

Table A-1 Site Roles/Responsibilities			
Site Role/Responsibility	Agency / Entity	Name	Title
USEPA-Lead	USEPA	Craig Benson	FOSC
START Project Manager	E&E	Mike Schwennesen	
START Safety Officer	E&E	Chris Myers	
ERRS Response Manager	EQM, Inc.	Gary Wofford	
ERRS Safety Officer	EQM, Inc.	Gary Wofford	

B. SITE CHARACTERIZATION

Site Description: The Iron King Mine – Humboldt Smelter site is located in Dewey-Humboldt, Yavapai County, Arizona. The site is a community (typically termed the “In-Town Area”) that is located between the Iron King Mine and the Humboldt Smelter. Three waterways (Chaparral Gulch, Galena Gulch, and Agua Fria River) transect the site. The Iron King Mine (IKM) property is approximately 153 acres in size. It is located west of Highway 69, bordered by the Chaparral Gulch and residences to the north; Highway 69 to the east; Galena Gulch to the south; and undeveloped land to the west. The IKM is a former lead, gold, silver, and zinc mine, and it has associated tailings piles and sediment ponds. The principal feature of the 85-acre portion of the Iron King Mine area of interest is a large (more than 50 acres) tailings pile, which contains high concentrations of arsenic and lead. The tailings are subject to off-site migration mainly via air particulate migration and surface water transport. At a residential property adjacent to the IKM exists an additional estimated 20,000 cubic yards of tailings deposited in a creek channel (“Small Tailings Pile”).

The Humboldt Smelter (HS) property is located less than one mile east of the Iron King Mine property, on the east side of Highway 69. The approximately 189-acre smelter property is bounded by residences to the north and west; the Agua Fria River to the east; and Chaparral Gulch to the south. The Humboldt Smelter area of interest includes tailings and slag deposit areas and an approximately 23-acre ash pile. The ash pile material is subject to off-site migration mainly via air particulate migration and surface water transport.

map:

The area is: 9 predominately commercial 9 predominately residential ☒ mixed commercial/residential 9 rural

Site History: Various environmental assessments and remedial investigations have been conducted at the mine, smelter, and site since about the late 1980s and the IKM-HS area is currently listed as a Superfund site on the National Priorities List. Based on soil sampling performed as part of the remedial investigations, portions of the site are known to have soils with elevated lead and arsenic concentrations. In the In-town Area, lead was detected at concentrations up to 18,100 milligrams per kilogram (mg/kg) and arsenic was detected at concentrations up to 817 mg/kg. START conducted assessment soil sampling in March and June 2011. Results from the START sampling supported the results of previous investigations in documenting elevated concentrations of lead (maximum 4,100 mg/kg) and arsenic (maximum 1,900 mg/kg). The EPA’s Emergency Response Section (ERS) is conducting a soil removal action in the In-Town Area.

Scope of Work: The Scope of Work for this project includes the following:

As part of the overall removal action at the site, the following primary tasks will be completed:

- Dust suppression at the smelter site through application of a soil sealant product to the approximately 10 acres of exposed ash (conducted by ERRS);
- Contaminated soil removal at 14 residential properties (ERRS will conduct the excavation, with confirmation soil sampling and air monitoring/sampling conducted by START);
- Relocation of the Small Tailings Pile to the main IKM tailings pile with application of soil sealant (conducted by ERRS, with soil sampling and air monitoring/sampling conducted by START);
- Creek restoration after removal of the Small Tailings Pile (conducted by ERRS, with air monitoring/sampling conducted by START).

During the main activities, START will also provide technical oversight and documentation support.

The individual activities that are required to complete the scope of work are divided into numbered tasks. Table B-1 provides a description of each numbered task.

Table B-1 Project Tasks and Task Descriptions	
Task Number	Task Description
1	Mobilization, Site Preparation, and Demobilization
2	Dust suppression of smelter ash through application of soil sealant (“gorilla snot”)
3	Contaminated soil excavation/removal
4	Relocation of the Small Tailings Pile followed by application of soil sealant
5	Creek channel restoration
6	Air Monitoring (health and safety) and air sampling (documentation of off-site migration of contaminants) during removal operations
7	Soil sampling as required to document residual contaminant concentrations after clean up
8	Decontamination of sampling/removal equipment as required.
9	Site documentation/oversight of removal activities

C. EVALUATION AND HAZARD CONTROL

This section identifies and describes safety and health hazards associated with site work. The hazards associated with each task, by site location are identified in the following table(s). Based on the best available knowledge of how that task will be performed, the likelihood of exposure to the hazards identified at that location specified and control measures implemented to protect employees from the hazard. Engineering controls, work practices, personal protective equipment, or a combination of these shall be implemented in accordance with 29 CFR 1910.120(g) to protect employees from exposure to health hazards.

Overall Hazard Summary		
Hazard (low, med, high)	Task (s)	Discussion
Low - Med	1	Heavy equipment/traffic awareness; weather extremes; electrocution prevention
Low - Med	2	Heavy equipment awareness; weather extremes
Med	3, 4	Contaminants in dust; heavy equipment/traffic awareness; weather extremes
Low - Med	5	Heavy equipment awareness; weather extremes
Low - Med	6	Contaminants in dust; heavy equipment awareness; weather extremes
Low	7	Contaminants in dust; heavy equipment awareness; weather extremes
Low	8	Heavy equipment awareness; weather extremes
Med	9	Contaminants in dust; heavy equipment awareness; weather extremes

Overall Control Measures		
Hazard	PPE	Discussion
Low	Level D	Steel toed/shanked boots; gloves; hard hat, tyvek coveralls if required
Medium	Level D (air monitoring will be conducted to ensure Level D PPE is appropriate)	Steel toed/shanked boots; gloves; hard hat, tyvek coveralls if required

Job Hazard Analysis (JHA)			
JHA Number	Task	Location Where Task Performed	
1	Mobilization, Site Preparation, and Demobilization	IKM-HS Site	
Date JHA conducted: 9/12/11-10/07/11		Date(s) JHA updated:	
Biological Hazards			
Name of Biological Hazard	Characteristics	Concentration	Exposure Potential during Task
Desert creatures (insects, spiders, snakes, rodents, Gila monster)/Hantavirus	☒ Infectious/Pathogenic ☒ Toxic	NA	9 High ☒ Low 9 Medium 9 Unknown
Chemical Hazards			
Chemical Name or Type	Characteristics	State/Concentration	Exposure Potential during Task
Lead, arsenic	9 Flammable / Ignitable 9 Corrosive ☒ Poison / Acutely Toxic 9 Air/Water Reactive ☒ Carcinogenic 9 Explosive/Shock Sensitive 9 Volatile	9 Gas/ Vapor ☒ Solid 9 Liquid	9 High ☒ Low 9 Medium 9 Unknown
See Table D-1 for a summary of Chemical information. Chemical Evaluation Sheet or Material Safety Data Sheets (MSDS) are located in Appendix A for known chemical hazards.			
Physical Hazards			
Type of Physical Hazard			Exposure Potential during Task
9 Overhead 9 Below Grade X Trip/Fall 9 Burn 9 Puncture 9 Cut 9 Splash X Animal/Insect/Plant X Noise X Heat Stress X Cold Stress X Other – electrocution, traffic, heavy equipment operation, muscle strain			9 High 9 Low ☒ Medium 9 Unknown
9 Ionizing Radiation 9 Alpha Particles 9 Beta Particles 9 Gamma Rays 9 Neutrons			9 High ☒ Low 9 Medium 9 Unknown
9 Confined Space (Hazards associated with permit required confined space (PRCS) entries will be addressed in separate document prepared by the contractor making the PRCS entry.			9 High ☒ Low 9 Medium 9 Unknown
Control Measures			
Engineering Controls: Limit set up operations to “clean” areas.			

Work Practices: (describe those work practices specific to this task or that differ from the general work practices described in Section G)

Limit set up operations to non-contaminated areas. Use qualified electrician during site set up. Use proper lifting techniques when lifting heavy equipment and bending. Use buddy system when lifting. Use mechanical devices for lifting greater than 60 pounds when possible. Exercise caution around moving vehicles. Use traffic spotter when loading and unloading equipment. Document site conditions from upwind.

PPE D: steel toed/shanked work boots, work gloves, tyvek coveralls if required, hard hat

Group	PPE Level	Modifications Allowed
USEPA	D	
START	D	
ERRS	D	

Job Hazard Analysis (JHA)			
JHA Number	Task	Location Where Task Performed	
2	Dust suppression of smelter ash through application of soil sealant	Humboldt Smelter	
Date JHA conducted: 9/12/11-10/07/11		Date(s) JHA updated:	
Biological Hazards			
Name of Biological Hazard	Characteristics	Concentration	Exposure Potential during Task
Desert creatures (insects, spiders, snakes, rodents, Gila monster)/Hantavirus	☒ Infectious/Pathogenic ☒ Toxic	NA	9 High ☒ Low 9 Medium 9 Unknown
Chemical Hazards			
Chemical Name or Type	Characteristics	State/Concentration	Exposure Potential during Task
Lead, arsenic	9 Flammable / Ignitable 9 Corrosive ☒ Poison / Acutely Toxic 9 Air/Water Reactive ☒ Carcinogenic 9 Explosive/Shock Sensitive 9 Volatile	9 Gas/ Vapor ☒ Solid 9 Liquid	9 High ☒ Low 9 Medium 9 Unknown
See Table D-1 for a summary of Chemical information. Chemical Evaluation Sheet or Material Safety Data Sheets (MSDS) are located in Appendix A for known chemical hazards.			
Physical Hazards			
Type of Physical Hazard			Exposure Potential during Task
9 Overhead 9 Below Grade X Trip/Fall 9 Burn 9 Puncture 9 Cut 9 Splash X Animal/Insect/Plant X Noise X Heat Stress X Cold Stress X Other – heavy equipment operation			9 High 9 Low ☒ Medium 9 Unknown
9 Ionizing Radiation 9 Alpha Particles 9 Beta Particles 9 Gamma Rays 9 Neutrons			9 High ☒ Low 9 Medium 9 Unknown
9 Confined Space (Hazards associated with permit required confined space (PRCS) entries will be addressed in separate document prepared by the contractor making the PRCS entry.			9 High ☒ Low 9 Medium 9 Unknown
Control Measures			
Engineering Controls: Work upwind of soil sealant application if possible.			

Work Practices: (describe those work practices specific to this task or that differ from the general work practices described in Section G)

Exercise caution around moving vehicles and heavy equipment (make eye contact). Use traffic spotter when loading and unloading equipment. Document site conditions from upwind.

PPE D: steel toed/shanked work/nitrile boots, work gloves, tyvek coveralls if required, hard hat

Group	PPE Level	Modifications Allowed
USEPA	D	
START	D	
ERRS	D	

Job Hazard Analysis (JHA)			
JHA Number	Task	Location Where Task Performed	
3	Contaminated soil excavation/removal	IKM-HS site residential properties	
Date JHA conducted: 9/12/11-10/07/11		Date(s) JHA updated:	
Biological Hazards			
Name of Biological Hazard	Characteristics	Concentration	Exposure Potential during Task
Desert creatures (insects, spiders, snakes, rodents, Gila monster)/Hantavirus	<input type="checkbox"/> Infectious/Pathogenic <input type="checkbox"/> Toxic	NA	<input type="checkbox"/> High <input type="checkbox"/> Low <input type="checkbox"/> Medium <input type="checkbox"/> Unknown
Chemical Hazards			
Chemical Name or Type	Characteristics	State/Concentration	Exposure Potential during Task
Lead, arsenic	<input type="checkbox"/> Flammable / Ignitable <input type="checkbox"/> Corrosive <input type="checkbox"/> Poison / Acutely Toxic <input type="checkbox"/> Air/Water Reactive <input type="checkbox"/> Carcinogenic <input type="checkbox"/> Explosive/Shock Sensitive <input type="checkbox"/> Volatile	<input type="checkbox"/> Gas/ Vapor <input type="checkbox"/> Solid <input type="checkbox"/> Liquid	<input type="checkbox"/> High <input type="checkbox"/> Low <input type="checkbox"/> Medium <input type="checkbox"/> Unknown
See Table D-1 for a summary of Chemical information. Chemical Evaluation Sheet or Material Safety Data Sheets (MSDS) are located in Appendix A for known chemical hazards.			
Physical Hazards			
Type of Physical Hazard			Exposure Potential during Task
<input type="checkbox"/> Overhead <input type="checkbox"/> Below Grade <input checked="" type="checkbox"/> Trip/Fall <input type="checkbox"/> Burn <input type="checkbox"/> Puncture <input type="checkbox"/> Cut <input type="checkbox"/> Splash <input checked="" type="checkbox"/> Animal/Insect/Plant <input checked="" type="checkbox"/> Noise <input checked="" type="checkbox"/> Heat Stress <input checked="" type="checkbox"/> Cold Stress <input checked="" type="checkbox"/> Other – traffic, heavy equipment operation			<input type="checkbox"/> High <input type="checkbox"/> Low <input type="checkbox"/> Medium <input type="checkbox"/> Unknown
<input type="checkbox"/> Ionizing Radiation <input type="checkbox"/> Alpha Particles <input type="checkbox"/> Beta Particles <input type="checkbox"/> Gamma Rays <input type="checkbox"/> Neutrons			<input type="checkbox"/> High <input type="checkbox"/> Low <input type="checkbox"/> Medium <input type="checkbox"/> Unknown
<input type="checkbox"/> Confined Space (Hazards associated with permit required confined space (PRCS) entries will be addressed in separate document prepared by the contractor making the PRCS entry.			<input type="checkbox"/> High <input type="checkbox"/> Low <input type="checkbox"/> Medium <input type="checkbox"/> Unknown
Control Measures			
Engineering Controls: Perform air monitoring to assure proper PPE is utilized. Use a water truck to keep soils wet and to control dust levels.			

Work Practices: (describe those work practices specific to this task or that differ from the general work practices described in Section G)

Exercise caution around moving vehicles and heavy equipment (make eye contact). Use traffic spotter when loading and unloading equipment. Document site conditions from upwind.

PPE D: steel toed/shanked work/nitrile boots, work gloves, tyvek coveralls if required, hard hat

Group	PPE Level	Modifications Allowed
USEPA	D	
START	D	
ERRS	D	

Job Hazard Analysis (JHA)			
JHA Number	Task	Location Where Task Performed	
4	Relocation of the Small Tailings Pile followed by application of soil sealant	OFS-002/IKM site	
Date JHA conducted: 9/12/11-10/07/11		Date(s) JHA updated:	
Biological Hazards			
Name of Biological Hazard	Characteristics	Concentration	Exposure Potential during Task
Desert creatures (insects, spiders, snakes, rodents, Gila monster)/Hantavirus	<input type="checkbox"/> Infectious/Pathogenic <input type="checkbox"/> Toxic	NA	<input type="checkbox"/> High <input type="checkbox"/> Low <input type="checkbox"/> Medium <input type="checkbox"/> Unknown
Chemical Hazards			
Chemical Name or Type	Characteristics	State/Concentration	Exposure Potential during Task
Lead, arsenic	<input type="checkbox"/> Flammable / Ignitable <input type="checkbox"/> Corrosive <input type="checkbox"/> Poison / Acutely Toxic <input type="checkbox"/> Air/Water Reactive <input type="checkbox"/> Carcinogenic <input type="checkbox"/> Explosive/Shock Sensitive <input type="checkbox"/> Volatile	<input type="checkbox"/> Gas/ Vapor <input type="checkbox"/> Solid <input type="checkbox"/> Liquid	<input type="checkbox"/> High <input type="checkbox"/> Low <input type="checkbox"/> Medium <input type="checkbox"/> Unknown
See Table D-1 for a summary of Chemical information. Chemical Evaluation Sheet or Material Safety Data Sheets (MSDS) are located in Appendix A for known chemical hazards.			
Physical Hazards			
Type of Physical Hazard			Exposure Potential during Task
<input type="checkbox"/> Overhead <input type="checkbox"/> Below Grade <input checked="" type="checkbox"/> Trip/Fall <input type="checkbox"/> Burn <input type="checkbox"/> Puncture <input type="checkbox"/> Cut <input type="checkbox"/> Splash <input checked="" type="checkbox"/> Animal/Insect/Plant <input checked="" type="checkbox"/> Noise <input checked="" type="checkbox"/> Heat Stress <input checked="" type="checkbox"/> Cold Stress <input checked="" type="checkbox"/> Other – traffic, heavy equipment operation			<input type="checkbox"/> High <input type="checkbox"/> Low <input type="checkbox"/> Medium <input type="checkbox"/> Unknown
<input type="checkbox"/> Ionizing Radiation <input type="checkbox"/> Alpha Particles <input type="checkbox"/> Beta Particles <input type="checkbox"/> Gamma Rays <input type="checkbox"/> Neutrons			<input type="checkbox"/> High <input type="checkbox"/> Low <input type="checkbox"/> Medium <input type="checkbox"/> Unknown
<input type="checkbox"/> Confined Space (Hazards associated with permit required confined space (PRCS) entries will be addressed in separate document prepared by the contractor making the PRCS entry.			<input type="checkbox"/> High <input type="checkbox"/> Low <input type="checkbox"/> Medium <input type="checkbox"/> Unknown
Control Measures			
Engineering Controls: Perform air monitoring to assure proper PPE is utilized. Use a water truck to keep soils wet and to control dust levels. Work upwind of soil sealant application if possible.			

Work Practices: (describe those work practices specific to this task or that differ from the general work practices described in Section G)

Exercise caution around moving vehicles and heavy equipment (make eye contact). Use traffic spotter when loading and unloading equipment. Document site conditions from upwind.

PPE D: steel toed/shanked work/nitrile boots, work gloves, tyvek coveralls if required, hard hat

Group	PPE Level	Modifications Allowed
USEPA	D	
START	D	
ERRS	D	

Job Hazard Analysis (JHA)			
JHA Number	Task	Location Where Task Performed	
5	Creek channel restoration	OFS-002 (residential property with Small Tailings Pile)	
Date JHA conducted: 9/12/11-10/07/11		Date(s) JHA updated:	
Biological Hazards			
Name of Biological Hazard	Characteristics	Concentration	Exposure Potential during Task
Desert creatures (insects, spiders, snakes, rodents, Gila monster)/Hantavirus	<input type="checkbox"/> Infectious/Pathogenic <input type="checkbox"/> Toxic	NA	<input type="checkbox"/> High <input type="checkbox"/> Low <input type="checkbox"/> Medium <input type="checkbox"/> Unknown
Chemical Hazards			
Chemical Name or Type	Characteristics	State/Concentration	Exposure Potential during Task
Lead, arsenic	<input type="checkbox"/> Flammable / Ignitable <input type="checkbox"/> Corrosive <input type="checkbox"/> Poison / Acutely Toxic <input type="checkbox"/> Air/Water Reactive <input type="checkbox"/> Carcinogenic <input type="checkbox"/> Explosive/Shock Sensitive <input type="checkbox"/> Volatile	<input type="checkbox"/> Gas/ Vapor <input type="checkbox"/> Solid <input type="checkbox"/> Liquid	<input type="checkbox"/> High <input type="checkbox"/> Low <input type="checkbox"/> Medium <input type="checkbox"/> Unknown
See Table D-1 for a summary of Chemical information. Chemical Evaluation Sheet or Material Safety Data Sheets (MSDS) are located in Appendix A for known chemical hazards.			
Physical Hazards			
Type of Physical Hazard			Exposure Potential during Task
<input type="checkbox"/> Overhead <input type="checkbox"/> Below Grade <input checked="" type="checkbox"/> Trip/Fall <input type="checkbox"/> Burn <input type="checkbox"/> Puncture <input type="checkbox"/> Cut <input type="checkbox"/> Splash <input checked="" type="checkbox"/> Animal/Insect/Plant <input checked="" type="checkbox"/> Noise <input checked="" type="checkbox"/> Heat Stress <input checked="" type="checkbox"/> Cold Stress <input checked="" type="checkbox"/> Other – heavy equipment operation			<input type="checkbox"/> High <input type="checkbox"/> Low <input type="checkbox"/> Medium <input type="checkbox"/> Unknown
<input type="checkbox"/> Ionizing Radiation <input type="checkbox"/> Alpha Particles <input type="checkbox"/> Beta Particles <input type="checkbox"/> Gamma Rays <input type="checkbox"/> Neutrons			<input type="checkbox"/> High <input type="checkbox"/> Low <input type="checkbox"/> Medium <input type="checkbox"/> Unknown
<input type="checkbox"/> Confined Space (Hazards associated with permit required confined space (PRCS) entries will be addressed in separate document prepared by the contractor making the PRCS entry.			<input type="checkbox"/> High <input type="checkbox"/> Low <input type="checkbox"/> Medium <input type="checkbox"/> Unknown
Control Measures			
Engineering Controls: Perform air monitoring to assure proper PPE is utilized.			

Work Practices: (describe those work practices specific to this task or that differ from the general work practices described in Section G)

Exercise caution around moving vehicles and heavy equipment (make eye contact). Use traffic spotter when loading and unloading equipment. Document site conditions from upwind.

PPE D: steel toed/shanked work boots, work gloves, tyvek coveralls if required, hard hat

Group	PPE Level	Modifications Allowed
USEPA	D	
START	D	
ERRS	D	

Job Hazard Analysis (JHA)			
JHA Number	Task	Location Where Task Performed	
6	Air monitoring/air sampling	Throughout site	
Date JHA conducted: 9/12/11-10/07/11		Date(s) JHA updated:	
Biological Hazards			
Name of Biological Hazard	Characteristics	Concentration	Exposure Potential during Task
Desert creatures (insects, spiders, snakes, rodents, Gila monster)/Hantavirus	☒ Infectious/Pathogenic ☒ Toxic	NA	9 High ☒ Low 9 Medium 9 Unknown
Chemical Hazards			
Chemical Name or Type	Characteristics	State/Concentration	Exposure Potential during Task
Lead, arsenic	9 Flammable / Ignitable 9 Corrosive ☒ Poison / Acutely Toxic 9 Air/Water Reactive ☒ Carcinogenic 9 Explosive/Shock Sensitive 9 Volatile	9 Gas/ Vapor ☒ Solid 9 Liquid	9 High 9 Low ☒ Medium 9 Unknown
See Table D-1 for a summary of Chemical information. Chemical Evaluation Sheet or Material Safety Data Sheets (MSDS) are located in Appendix A for known chemical hazards.			
Physical Hazards			
Type of Physical Hazard			Exposure Potential during Task
9 Overhead 9 Below Grade X Trip/Fall 9 Burn 9 Puncture 9 Cut 9 Splash X Animal/Insect/Plant X Noise X Heat Stress X Cold Stress X Other – heavy equipment operation			9 High ☒ Low 9 Medium 9 Unknown
9 Ionizing Radiation 9 Alpha Particles 9 Beta Particles 9 Gamma Rays 9 Neutrons			9 High ☒ Low 9 Medium 9 Unknown
9 Confined Space (Hazards associated with permit required confined space (PRCS) entries will be addressed in separate document prepared by the contractor making the PRCS entry.			9 High ☒ Low 9 Medium 9 Unknown
Control Measures			
Engineering Controls: Perform air monitoring to assure proper PPE is utilized.			

Work Practices: (describe those work practices specific to this task or that differ from the general work practices described in Section G)

Exercise caution around moving vehicles and heavy equipment (make eye contact).

PPE D: steel toed/shanked work boots, work gloves, tyvek coveralls if required, hard hat

Group	PPE Level	Modifications Allowed
USEPA	D	
START	D	
ERRS	D	

Job Hazard Analysis (JHA)			
JHA Number	Task	Location Where Task Performed	
7	Soil sampling	Soil removal areas of site	
Date JHA conducted: 9/12/11-10/07/11		Date(s) JHA updated:	
Biological Hazards			
Name of Biological Hazard	Characteristics	Concentration	Exposure Potential during Task
Desert creatures (insects, spiders, snakes, rodents, Gila monster)/Hantavirus	<input type="checkbox"/> Infectious/Pathogenic <input type="checkbox"/> Toxic	NA	<input type="checkbox"/> High <input type="checkbox"/> Low <input type="checkbox"/> Medium <input type="checkbox"/> Unknown
Chemical Hazards			
Chemical Name or Type	Characteristics	State/Concentration	Exposure Potential during Task
Lead, arsenic	<input type="checkbox"/> Flammable / Ignitable <input type="checkbox"/> Corrosive <input type="checkbox"/> Poison / Acutely Toxic <input type="checkbox"/> Air/Water Reactive <input type="checkbox"/> Carcinogenic <input type="checkbox"/> Explosive/Shock Sensitive <input type="checkbox"/> Volatile	<input type="checkbox"/> Gas/ Vapor <input type="checkbox"/> Solid <input type="checkbox"/> Liquid	<input type="checkbox"/> High <input type="checkbox"/> Low <input type="checkbox"/> Medium <input type="checkbox"/> Unknown
See Table D-1 for a summary of Chemical information. Chemical Evaluation Sheet or Material Safety Data Sheets (MSDS) are located in Appendix A for known chemical hazards.			
Physical Hazards			
Type of Physical Hazard			Exposure Potential during Task
<input type="checkbox"/> Overhead <input type="checkbox"/> Below Grade <input checked="" type="checkbox"/> Trip/Fall <input type="checkbox"/> Burn <input type="checkbox"/> Puncture <input type="checkbox"/> Cut <input type="checkbox"/> Splash <input checked="" type="checkbox"/> Animal/Insect/Plant <input checked="" type="checkbox"/> Noise <input checked="" type="checkbox"/> Heat Stress <input checked="" type="checkbox"/> Cold Stress <input checked="" type="checkbox"/> Other – heavy equipment operation			<input type="checkbox"/> High <input type="checkbox"/> Low <input type="checkbox"/> Medium <input type="checkbox"/> Unknown
<input type="checkbox"/> Ionizing Radiation <input type="checkbox"/> Alpha Particles <input type="checkbox"/> Beta Particles <input type="checkbox"/> Gamma Rays <input type="checkbox"/> Neutrons			<input type="checkbox"/> High <input type="checkbox"/> Low <input type="checkbox"/> Medium <input type="checkbox"/> Unknown
<input type="checkbox"/> Confined Space (Hazards associated with permit required confined space (PRCS) entries will be addressed in separate document prepared by the contractor making the PRCS entry.			<input type="checkbox"/> High <input type="checkbox"/> Low <input type="checkbox"/> Medium <input type="checkbox"/> Unknown
Control Measures			
Engineering Controls: Perform air monitoring to assure proper PPE is utilized.			

Work Practices: (describe those work practices specific to this task or that differ from the general work practices described in Section G)

Exercise caution around moving vehicles and heavy equipment (make eye contact).

PPE D: steel toed/shanked work boots, work gloves, tyvek coveralls if required, hard hat

Group	PPE Level	Modifications Allowed
USEPA	D	
START	D	
ERRS	D	

Job Hazard Analysis (JHA)			
JHA Number	Task	Location Where Task Performed	
8	Decontamination of sampling/ removal equipment as required	IKM-HS site	
Date JHA conducted: 9/12/11-10/07/11		Date(s) JHA updated:	
Biological Hazards			
Name of Biological Hazard	Characteristics	Concentration	Exposure Potential during Task
Desert creatures (insects, spiders, snakes, rodents, Gila monster)/Hantavirus	☐ Infectious/Pathogenic ☐ Toxic	NA	9 High ☐ Low 9 Medium 9 Unknown
Chemical Hazards			
Chemical Name or Type	Characteristics	State/Concentration	Exposure Potential during Task
Lead, arsenic	9 Flammable / Ignitable 9 Corrosive ☐ Poison / Acutely Toxic 9 Air/Water Reactive ☐ Carcinogenic 9 Explosive/Shock Sensitive 9 Volatile	9 Gas/ Vapor ☐ Solid 9 Liquid	9 High ☐ Low 9 Medium 9 Unknown
See Table D-1 for a summary of Chemical information. Chemical Evaluation Sheet or Material Safety Data Sheets (MSDS) are located in Appendix A for known chemical hazards.			
Physical Hazards			
Type of Physical Hazard			Exposure Potential during Task
9 Overhead 9 Below Grade X Trip/Fall 9 Burn 9 Puncture 9 Cut 9 Splash X Animal/Insect/Plant X Noise X Heat Stress X Cold Stress X Other – heavy equipment operation			9 High ☐ Low 9 Medium 9 Unknown
9 Ionizing Radiation 9 Alpha Particles 9 Beta Particles 9 Gamma Rays 9 Neutrons			9 High ☐ Low 9 Medium 9 Unknown
9 Confined Space (Hazards associated with permit required confined space (PRCS) entries will be addressed in separate document prepared by the contractor making the PRCS entry.			9 High ☐ Low 9 Medium 9 Unknown
Control Measures			
Engineering Controls: Limit set up to hot zone/contaminant reduction zone.			

Work Practices: (describe those work practices specific to this task or that differ from the general work practices described in Section G)

Exercise caution around moving vehicles and heavy equipment (make eye contact). Use traffic spotter when loading and unloading equipment. Document site conditions from upwind.

PPE D: steel toed/shanked work boots, work gloves, tyvek coveralls if required, hard hat

Group	PPE Level	Modifications Allowed
USEPA	D	
START	D	
ERRS	D	

Job Hazard Analysis (JHA)			
JHA Number	Task	Location Where Task Performed	
9	Site documentation/ oversight of removal activities	IKM-HS site	
Date JHA conducted: 9/12/11-10/07/11		Date(s) JHA updated:	
Biological Hazards			
Name of Biological Hazard	Characteristics	Concentration	Exposure Potential during Task
Desert creatures (insects, spiders, snakes, rodents, Gila monster)/Hantavirus	☐ Infectious/Pathogenic ☐ Toxic	NA	9 High ☐ Low 9 Medium 9 Unknown
Chemical Hazards			
Chemical Name or Type	Characteristics	State/Concentration	Exposure Potential during Task
Lead, arsenic	9 Flammable / Ignitable 9 Corrosive ☐ Poison / Acutely Toxic 9 Air/Water Reactive ☐ Carcinogenic 9 Explosive/Shock Sensitive 9 Volatile	9 Gas/ Vapor ☐ Solid 9 Liquid	9 High 9 Low ☐ Medium 9 Unknown
See Table D-1 for a summary of Chemical information. Chemical Evaluation Sheet or Material Safety Data Sheets (MSDS) are located in Appendix A for known chemical hazards.			
Physical Hazards			
Type of Physical Hazard			Exposure Potential during Task
9 Overhead 9 Below Grade X Trip/Fall 9 Burn 9 Puncture 9 Cut 9 Splash X Animal/Insect/Plant X Noise X Heat Stress X Cold Stress X Other – heavy equipment operation			9 High 9 Low ☐ Medium 9 Unknown
9 Ionizing Radiation 9 Alpha Particles 9 Beta Particles 9 Gamma Rays 9 Neutrons			9 High ☐ Low 9 Medium 9 Unknown
9 Confined Space (Hazards associated with permit required confined space (PRCS) entries will be addressed in separate document prepared by the contractor making the PRCS entry.			9 High ☐ Low 9 Medium 9 Unknown
Control Measures			
Engineering Controls: Perform air monitoring to assure proper PPE is utilized. Limit work to “clean” areas when possible.			

Work Practices: (describe those work practices specific to this task or that differ from the general work practices described in Section G)

Exercise caution around moving vehicles and heavy equipment (make eye contact). Document site conditions from upwind.

PPE D: steel toed/shanked work boots, work gloves, tyvek coveralls if required, hard hat

Group	PPE Level	Modifications Allowed
USEPA	D	
START	D	
ERRS	D	

D. CHEMICAL HAZARDS

Table D-1 Chemical Compound Information Summary							
Compound	Exposure Limits			IDLH Level	Route(s) of Exposure	Acute Symptoms	Odor Threshold/ Description
	PEL	REL	TLV				
Arsenic*	0.010 mg/m ³	0.002 mg/m ³ Ceiling (15 minute)	0.01 mg/m ³	5 mg/m ³	Inhalation, ingestion, absorption, skin or eye contact	Ulceration of septum, dermatitis, GI disturbances	None
Lead	0.050 mg/m ³	0.050 mg/m ³	0.05 mg/m ³	100 mg/m ³	Inhalation, ingestion, skin or eye contact	Lassitude, irritated eyes	None

Note: Use an asterisk (*) to indicate known or suspected carcinogens.

E. ACTION LEVELS AND HEALTH AND SAFETY MONITORING

Delete information for biological agents not of concern at the site.

Table E-1 Site-Specific Action Levels				
Contaminant	Level	Action	Level	Action
Arsenic (OFS-002 property only)	2.53 mg/m ³ (dust concentration)	Cease operations, apply engineering controls		
Total dust	2.5 mg/m ³	Evaluate necessity of additional engineering controls	5 mg/m ³	Cease operations, apply engineering controls

Table E-2 General Action Levels				
Contaminant	Level	Action	Level	Action
Oxygen	19.5% - 22%	Continue work in Level D or C	< 19.5% or > 22%	Upgrade to Level B or A
Lower Explosive Limit (LEL)	10 to 25% of LEL	Continuous monitoring	> 25% of LEL	Evacuate immediately
Particulates	≥ 5 mg/m ³ (assume all dust is respirable dust)	Upgrade to Level C		
Radiation	Above background but <1 mR/hr	Continue monitoring	≥1 mR/hr	Withdraw, contact Health Physicist and reassess work plan
Unknown Organic Vapors/Gases	Background to 1 part per million (ppm)	Level D with continuous monitoring	> 5 ppm to ≤500 ppm	Level B
	1 ppm to ≤ 5 ppm	Level C with continuous monitoring	>500 ppm	Level A
Other:				

F. DECONTAMINATION PROCEDURES

All equipment, materials, and personnel will be evaluated for contamination upon leaving the exclusion area. Equipment and materials will be decontaminated and/or disposed and personnel will be decontaminated, as necessary. Decontamination will be performed in the contamination reduction area or any designated area such that the exposure of uncontaminated employees, equipment, and materials will be minimized. Specific procedures are described below.

Table F-1 Decontamination Procedures:	
Type	Responsible Entity
<p>Personnel: PPE will be removed in the order and manner described in the <i>Guidelines for Removal of Protective Clothing</i> RAG.</p> <p>Disposable PPE will be directed to the proper waste stream. Contaminated spots identified on nondisposable PPE, including respirators and hard hats, will be decontaminated using controlled dry or damp methods (e.g. towelettes) Respirators may also be directed to the respirator washing station for full decontamination.</p> <p>Contaminated areas on the skin or body will be decontaminated using controlled dry or damp methods (e.g. towelettes). All contamination incidents on the skin or body will be documented in a Personnel Decontamination Form.</p>	EPA/ERRS/START
<p>Equipment/Instruments: Equipment/instruments will be washed with soap (alconox) and rinsed with water. Dedicated contaminated items will be disposed of.</p>	ERRS/START
<p>Emergency Decon: Non Life Threatening: Remove PPE, wash with soap and water and transport to hospital</p> <p>Life Threatening: Remove PPE and transport to hospital</p>	All
<p>Waste Management: Waste will be disposed of in accordance with applicable regulations by ERRS</p>	ERRS

G. SITE CONTROL

Draw site map indicating work zones.

Buddy System: All on-site personnel shall comply with the buddy system. The buddy system will be maintained on a line-of-sight basis.

Work Practices and Site Control Measures Common to All Site Tasks

1. The exclusion zone and contamination reduction zone (CRZ) will be clearly marked and access to it restricted to those personnel directly involved with the response operations.
2. Entry and exit corridors leading to the CRZ will be clearly marked.
3. Exclusion and CRZ zone entry and egress protocols will be established prior to any entry to these zones.
4. Prior to entering the exclusion zone and CRZ, personnel will know their specific tasks for the entry.
5. Personnel will enter and exit the exclusion zone only through designated corridors, which are located in and traverse the CRZ, unless emergency exiting of the facility is required.

6. Communications:

On-Site Radio Frequencies: Not used on this site.

Cell Phone #: Craig Benson, EPA OSC: 562-889-1630

Gary Wofford, ERRS: 714-269-5979

Mike Schwennesen, START: 760-689-8000

Hand Signals: Use appropriately

Illumination: All work will be conducted during daytime operational period unless sufficient artificial lighting in compliance with 29 CFR 1910.120(m) has been provided.

Sanitation: All work sites will be in compliance with the requirements pursuant to 29 CFR 1910.120(n).

H. TRAINING/MEDICAL SURVEILLANCE

Check all that apply:

Table H-1 Personnel Training and Surveillance Requirements				
Regulation	USEPA	START	ERRS	Other
29 CFR 1910.120(e)(3)(i): General Site Worker - 40 hr	X	X	X	
29 CFR 1910.120(e)(3)(ii): Occasional Worker - 24 hr				
29 CFR 1910.120(e)(3)(iii): Workers in Area <PEL - 24 hr				
29 CFR 1910.120(e)(4): Management & Supervisors - 40/8 hr	X	X	X	
29 CFR 1910.120(e)(7): Emergency Response				
29 CFR 1910.120(e)(8): Refresher - 8 hr	X	X	X	
First Responder Awareness				
First Responder Operational - 8 hr				
Hazmat Technician - 24 hr				
Hazmat Specialist- 24 hr				
On-Scene Commander - 24 hr				
29 CFR 1910.134: Resp. Std.				
29 CFR 1910.146: PRCs				
29 CFR 1910.120(f): Medical Surveillance Participation	X	X	X	
8-Hour General Radiation Training				
Radiation Exposure Surveillance - External Dosimetry (TLD Badge and/or electronic dosimeters)				

I. EMERGENCY RESPONSE PLAN

This section contains additional information pertaining to on-site emergency response and does not duplicate pertinent emergency response information contained in earlier sections of this plan (e.g., site layout, monitoring equipment, etc.). Emergency response procedures will be rehearsed regularly, as applicable, during project activities.

Section I.1 Emergency Responsibilities

Section I.1.1 All Personnel: All personnel shall be alert to the possibility of an on-site emergency; report potential or actual emergency situations directly to supervision or to the FOSC, SSO and RSO; When practicable, the lead Federal official on-site will make the decision to declare a site emergency and notify appropriate emergency resources, as necessary.

Section I.1.2 Entry Team Leader: The team leader will determine the emergency actions to be performed by site personnel and will direct these actions. The team leader also will ensure that applicable incidents are reported to appropriate project personnel and the FOSC. The FOSC will determine what other government agency notifications are required.

Section I.1.3 SSO: The SSO will recommend health/safety and protective measures appropriate to the emergency. The SSO is authorized to terminate all activities deemed to be unsafe. In the case of an emergency, the SSO shall call 911 or designate someone to call 911.

Section I.1.4 RSO: The RSO is responsible for all radiation safety issues. If emergency decontamination is required, the RSO shall supervise.

Section I.1.5 FOSC: The FOSC has overall responsibility for all emergency operations. The FOSC shall interface with all rescue personnel.

On-Site Emergency Signal: Three long horn blasts

On-Site Meeting Location: EPA/ERRS/START office trailer _____

Emergency Egress Route Off-Site: See Map to Hospital _____

Off-Site Meeting Location: TBD at first tailgate safety meeting _____

Emergency Decontamination Procedures: Remove PPE and transport to hospital

Company/Resource	Name Contact	Telephone Numbers
USEPA	Region Response Center Harry Allen, ERS Chief OSC: Craig Benson	(800) 300-2193 (415) 972-3063 (Office) (415) 218-7406 (Cell) (562) 889-1630 (Cell)
START	Cindy McLeod Sara Dwight	(415) 238-3379 (Cell) (510) 654-6250 (Home) (415) 264-8246 (Cell)
ERRS	RM: Gary Wofford	(714) 269-5979
Hospital (Route Map Appendix B)	Yavapai Regional Medical Center- East, 7700 East Florentine Road, Prescott Valley, AZ 86314	(928) 445-2700
Poison Control Center		1-800-222-1222
Police		911
Fire		911
Site	USEPA: Craig Benson START: Mike Schwennesen ERRS: Gary Wofford	(562) 889-1630 (Cell) (760) 689-8000 (714) 269-5979

Participant Acknowledgment Sheet

<u>Name</u>	<u>Organization</u>	<u>Date</u>

Appendix A: Chemical Hazard Sheets



Search the Pocket Guide

Enter search terms separated by spaces.

Arsenic (inorganic compounds, as As)

Synonyms & Trade Names Arsenic metal: Arsenia

Other synonyms vary depending upon the specific As compound. [Note: OSHA considers "Inorganic Arsenic" to mean copper acetoarsenite and all inorganic compounds containing arsenic except ARSINE.]

CAS No. 7440-38-2
(metal)

RTECS No. CG0525000
(metal) (</niosh-rtecs/CG802C8.html>)

DOT ID & Guide 1558 152
<http://wwwapps.tc.gc.ca/saf-sec-sur/3/erg-gmu/erg/guidepage.aspx?guide=152> (metal)
 1562 152 (<http://wwwapps.tc.gc.ca/saf-sec-sur/3/erg-gmu/erg/guidepage.aspx?guide=152>)
 (dust)

Formula As (metal)

Conversion

IDLH Ca [5 mg/m³ (as As)]
 See: [7440382 \(/niosh/idlh/7440382.html\)](/niosh/idlh/7440382.html)

Exposure Limits

NIOSH REL : Ca C 0.002 mg/m³ [15-minute] See [Appendix A \(nengapdx.html\)](#)

OSHA PEL : [1910.1018] TWA 0.010 mg/m³

Measurement Methods

NIOSH 7300 (</niosh/docs/2003-154/pdfs/7300.pdf>), **7301** (</niosh/docs/2003-154/pdfs/7301.pdf>), **7303** (</niosh/docs/2003-154/pdfs/7303.pdf>), **7900** (</niosh/docs/2003-154/pdfs/7900.pdf>), **9102** (</niosh/docs/2003-154/pdfs/9102.pdf>);

OSHA ID105 (<http://www.osha.gov/dts/sltc/methods/inorganic/id105/id105.html>)
 See: [NMAM \(/niosh/docs/2003-154/\)](/niosh/docs/2003-154/) or [OSHA Methods](#) (<http://www.osha.gov/dts/sltc/methods/index.html>)

Physical Description Metal: Silver-gray or tin-white, brittle, odorless solid.

MW:
74.9

BP:
Sublimes

MLT: 1135°F
(Sublimes)

Sol:
Insoluble

VP: 0 mmHg (approx)

IP: NA

Sp.Gr:
5.73
(metal)

FLP: NA

UEL: NA

LEL: NA

Metal: Noncombustible Solid in bulk form, but a slight explosion hazard in the form of dust when exposed to flame.

Incompatibilities & Reactivities Strong oxidizers, bromine azide [Note: Hydrogen gas can react with inorganic arsenic to form the highly toxic gas arsine.]

Exposure Routes inhalation, skin absorption, skin and/or eye contact, ingestion

Symptoms Ulceration of nasal septum, dermatitis, gastrointestinal disturbances, peripheral neuropathy, resp irritation, hyperpigmentation of skin, [potential occupational carcinogen]

Target Organs Liver, kidneys, skin, lungs, lymphatic system

Cancer Site [lung & lymphatic cancer]

Personal Protection/Sanitation (See [protection codes](#) ([protect.html](#)))

Skin: Prevent skin contact

Eyes: Prevent eye contact

Wash skin: When contaminated/Daily

Remove: When wet or contaminated

Change: Daily

Provide: Eyewash, Quick drench

First Aid (See [procedures](#) ([firstaid.html](#)))

Eye: Irrigate immediately

Skin: Soap wash immediately

Breathing: Respiratory support

Swallow: Medical attention immediately

Respirator Recommendations

(See [Appendix E](#)) ([nengapdx.html](#))

NIOSH

At concentrations above the NIOSH REL, or where there is no REL, at any detectable concentration:

(APF = 10,000) Any self-contained breathing apparatus that has a full facepiece and is operated in a pressure-demand or other positive-pressure mode

(APF = 10,000) Any supplied-air respirator that has a full facepiece and is operated in a pressure-demand or other positive-pressure mode in combination with an auxiliary self-contained positive-pressure breathing apparatus

Escape:

(APF = 50) Any air-purifying, full-facepiece respirator (gas mask) with a chin-style, front- or back-mounted acid gas canister having an N100, R100, or P100 filter.

[Click here](#) ([pgintrod.html#nrp](#)) for information on selection of N, R, or P filters.

Any appropriate escape-type, self-contained breathing apparatus

[Important additional information about respirator selection](#) ([pgintrod.html#mustread](#))

See also: [INTRODUCTION](#) ([/niosh/npg/pgintrod.html](#)) See ICSC CARD: [0013](#) ([/niosh/ipcsneng/neng0013.html](#)) See MEDICAL TESTS: [0017](#) ([/niosh/docs/2005-110/nmed0017.html](#))

Page last reviewed: April 4, 2011

Page last updated: November 18, 2010

Content source: [National Institute for Occupational Safety and Health \(NIOSH\)](#) Education and Information Division

Centers for Disease Control and Prevention 1600 Clifton Rd. Atlanta, GA 30333, USA
800-CDC-INFO (800-232-4636) TTY: (888) 232-6348, New Hours of Operation
8am-8pm ET/Monday-Friday
Closed Holidays - cdcinfo@cdc.gov





Centers for Disease Control and Prevention

CDC 24/7: Saving Lives. Protecting People. Saving Money through Prevention.

Search the Pocket Guide

Enter search terms separated by spaces.

Lead

Synonyms & Trade Names Lead metal, Plumbum

CAS No. 7439-92-1	RTECS No. OF7525000 (/niosh-rtecs/OF72D288.html)	DOT ID & Guide
-----------------------------	--	---------------------------

Formula Pb	Conversion	IDLH 100 mg/m ³ (as Pb) See: 7439921 (/niosh/idlh/7439921.html)
-------------------	-------------------	--

Exposure Limits

NIOSH REL *: TWA (8-hour) 0.050 mg/m³ See [Appendix C \(nengapdx.html\)](#) [*Note: The REL also applies to other lead compounds (as Pb) -- see Appendix C.]

OSHA PEL *: [1910.1025] TWA 0.050 mg/m³ See [Appendix C \(nengapdx.html\)](#) [*Note: The PEL also applies to other lead compounds (as Pb) -- see Appendix C.]

Measurement Methods

NIOSH 7082 (/niosh/docs/2003-154/pdfs/7082.pdf), **7105** (/niosh/docs/2003-154/pdfs/7105.pdf), **7300** (/niosh/docs/2003-154/pdfs/7300.pdf), **7301** (/niosh/docs/2003-154/pdfs/7301.pdf), **7303** (/niosh/docs/2003-154/pdfs/7303.pdf), **7700** (/niosh/docs/2003-154/pdfs/7700.pdf), **7701** (/niosh/docs/2003-154/pdfs/7701.pdf), **7702** (/niosh/docs/2003-154/pdfs/7702.pdf), **9100** (/niosh/docs/2003-154/pdfs/9100.pdf), **9102** (/niosh/docs/2003-154/pdfs/9102.pdf), **9105** (/niosh/docs/2003-154/pdfs/9105.pdf);

OSHA ID121 (<http://www.osha.gov/dts/sltc/methods/inorganic/id121/id121.html>), **ID125G** (<http://www.osha.gov/dts/sltc/methods/inorganic/id125g/id125g.html>), **ID206** (<http://www.osha.gov/dts/sltc/methods/inorganic/id206/id206.html>)
See: [NMAM](#) (/niosh/docs/2003-154/) or [OSHA Methods](#) (<http://www.osha.gov/dts/sltc/methods/index.html>)

Physical Description A heavy, ductile, soft, gray solid.

MW: 207.2	BP: 3164°F	MLT: 621°F	Sol: Insoluble	VP: 0 mmHg (approx)	IP: NA
Sp.Gr: 11.34	Fl.P: NA	UEL: NA	LEL: NA		

Noncombustible Solid in bulk form.	
Incompatibilities & Reactivities Strong oxidizers, hydrogen peroxide, acids	
Exposure Routes inhalation, ingestion, skin and/or eye contact	
Symptoms lassitude (weakness, exhaustion), insomnia; facial pallor; anorexia, weight loss, malnutrition; constipation, abdominal pain, colic; anemia; gingival lead line; tremor; paralysis wrist, ankles; encephalopathy; kidney disease; irritation eyes; hypertension	
Target Organs Eyes, gastrointestinal tract, central nervous system, kidneys, blood, gingival tissue	
<p>Personal Protection/Sanitation (See protection codes (protect.html))</p> <p>Skin: Prevent skin contact</p> <p>Eyes: Prevent eye contact</p> <p>Wash skin: Daily</p> <p>Remove: When wet or contaminated</p> <p>Change: Daily</p>	<p>First Aid (See procedures (firstaid.html))</p> <p>Eye: Irrigate immediately</p> <p>Skin: Soap flush promptly</p> <p>Breathing: Respiratory support</p> <p>Swallow: Medical attention immediately</p>
<p>Respirator Recommendations (See Appendix E (nengapdx.html))</p> <p>NIOSH/OSHA</p> <p>Up to 0.5 mg/m³: (APF = 10) Any air-purifying respirator with an N100, R100, or P100 filter (including N100, R100, and P100 filtering facepieces) except quarter-mask respirators. Click here (pgintrod.html#nrp) for information on selection of N, R, or P filters. (APF = 10) Any supplied-air respirator</p> <p>Up to 1.25 mg/m³: (APF = 25) Any supplied-air respirator operated in a continuous-flow mode (APF = 25) Any powered, air-purifying respirator with a high-efficiency particulate filter.</p> <p>Up to 2.5 mg/m³: (APF = 50) Any air-purifying, full-facepiece respirator with an N100, R100, or P100 filter. Click here (pgintrod.html#nrp) for information on selection of N, R, or P filters. (APF = 50) Any supplied-air respirator that has a tight-fitting facepiece and is operated in a continuous-flow mode (APF = 50) Any powered, air-purifying respirator with a tight-fitting facepiece and a high-efficiency particulate filter (APF = 50) Any self-contained breathing apparatus with a full facepiece (APF = 50) Any supplied-air respirator with a full facepiece</p> <p>Up to 50 mg/m³: (APF = 1000) Any supplied-air respirator operated in a pressure-demand or other positive-pressure mode</p> <p>Up to 100 mg/m³: (APF = 2000) Any supplied-air respirator that has a full facepiece and is operated in a pressure-demand or other positive-pressure mode</p>	

Emergency or planned entry into unknown concentrations or IDLH conditions:

(APF = 10,000) Any self-contained breathing apparatus that has a full facepiece and is operated in a pressure-demand or other positive-pressure mode

(APF = 10,000) Any supplied-air respirator that has a full facepiece and is operated in a pressure-demand or other positive-pressure mode in combination with an auxiliary self-contained positive-pressure breathing apparatus

Escape:

(APF = 50) Any air-purifying, full-facepiece respirator with an N100, R100, or P100 filter.

[Click here \(pgintrod.html#nrp\)](#) for information on selection of N, R, or P filters.

Any appropriate escape-type, self-contained breathing apparatus

[Important additional information about respirator selection \(pgintrod.html#mustread\)](#)

See also: [INTRODUCTION \(/niosh/npg/pgintrod.html\)](#) See ICSC CARD: [0052 \(/niosh/ipcsneng/neng0052.html\)](#) See MEDICAL TESTS: [0127 \(/niosh/docs/2005-110/nmed0127.html\)](#)

Page last reviewed: April 4, 2011

Page last updated: November 18, 2010

Content source: [National Institute for Occupational Safety and Health \(NIOSH\)](#) Education and Information Division

Centers for Disease Control and Prevention 1600 Clifton Rd. Atlanta, GA 30333, USA

800-CDC-INFO (800-232-4636) TTY: (888) 232-6348, New Hours of Operation

8am-8pm ET/Monday-Friday

Closed Holidays - cdcinfo@cdc.gov



HEAT STRESS PREVENTION AND TREATMENT

Elevated temperatures are potentially hazardous, especially when work is conducted without appropriate precautions. The following sections describe heat stress prevention and the recognition and treatment of heat emergencies.

Effects of Heat

A predictable amount of heat is generated as a result of normal oxidation processes within the body. If heat is liberated rapidly, the body cools to a point at which the production of heat is accelerated, and the excess heat brings the body temperature back to normal.

Interference with the elimination of heat leads to its accumulation and to the elevation of body temperature. This condition produces a vicious cycle in which certain body processes accelerate and generate additional heat. Afterward, the body must eliminate not only the heat that is normally generated but also the additional quantities of heat.

Most body heat is brought to the surface by the bloodstream and escapes to cooler surroundings by conduction and radiation. If moving air or a breeze strikes the body, additional heat is lost by convection. When the temperature of the surrounding air becomes equal to or rises above the body temperature, all the heat must be lost by vaporization of the moisture or sweat from skin surfaces. As the air becomes more humid (contains more moisture), vaporization from the skin decreases. Weather conditions including high temperatures (90 to 100 degrees F), high humidity, and little or no breeze cause the retention of body heat. Such conditions or a succession of such days (a heat wave) increase the chances of a medical emergency due to heat.

Preventing Emergencies Due to Heat

When working in situations where the ambient temperatures and humidity are high, and especially in situations where protection levels A, B, or C are required, the site safety officer should:

- Ensure that all employees drink plenty of fluids (Gatorade or its equivalent);
- Ensure that frequent breaks are scheduled so overheating does not occur; and
- Revise work schedules, when necessary, to take advantage of the cooler parts of the day (i.e., 5:00 a.m. to 11:00 a.m. and 6:00 p.m. to nightfall).

When protective clothing is required, the suggested guidelines correlating ambient temperature and maximum wearing time per excursion are:

Ambient Temperature	Maximum Wearing Time per Excursion
Above 90 degrees F	15 minutes
85 to 90 degrees F	30 minutes
80 to 85 degrees F	60 minutes
70 to 80 degrees F	90 minutes
60 to 70 degrees F	120 minutes
50 to 60 degrees F	180 minutes

One method of measuring the effectiveness of an employee's rest-recovery regime is by monitoring the heart rate. The "Brouha guideline" is one such method and is performed as follows:

- Count the pulse rate for the last 30 seconds of the first minute of a 3-minute period, the last 30 seconds of the second minute, and the last 30 seconds of the third minute; and
- Double each result to yield beats per minute.

If the recovery pulse rate during the last 30 seconds of the first minute is 110 beats/minute or less, and the deceleration between the first, second, and third minutes is at least 10 beats/minute, then the work-recovery regime is acceptable. If the employee's rate is above the rate specified, a longer rest period will be required, accompanied by an increased intake of fluids.

Heat Emergencies

Heat Cramps. Heat cramps usually affect people who work in hot environments and perspire a great deal. Loss of salt from the body causes very painful cramps in leg and abdominal muscles. Heat cramps may also result from drinking iced water or other drinks either too quickly or in too large a quantity. The symptoms of heat cramps are:

- Painful muscle cramps in legs and abdomen;
- Faintness; and
- Profuse perspiration.

To provide emergency care for heat cramps, move the patient to a cool place. Give him or her sips of liquids such as Gatorade or its equivalent. Apply manual pressure to the cramped muscle. Move the patient to a hospital if there is any indication of a more serious problem.

Heat Exhaustion. Heat exhaustion also may occur in individuals working in hot environments and may be associated with heat cramps. Heat exhaustion is caused by the pooling of blood in the vessels of the skin. The heat is transported from the interior of the body to the surface by the blood. The skin vessels become dilated and a large amount of blood is pooled in the skin. This condition, plus the blood that is pooled in the lower extremities when in an upright position, may lead to an inadequate return of blood to the heart and eventual physical collapse. The symptoms of heat exhaustion are:

- Weak pulse;

- Rapid and usually shallow breathing;
- Generalized weakness;
- Pale, clammy skin;
- Profuse perspiration;
- Dizziness/faintness; and
- Unconsciousness.

To provide emergency care for heat exhaustion, move the patient to a cool place and remove as much clothing as possible. Have the patient drink cool water, Gatorade, or its equivalent. If possible, fan the patient continually to remove heat by convection, but do not allow chilling or overcooling. Treat the patient for shock and move him or her to a medical facility if there is any indication of a more serious problem.

Heat Stroke. Heat stroke is a profound disturbance of the heat-regulating mechanism and is associated with high fever and collapse. It is a serious threat to life and carries a 20% mortality rate. Sometimes this condition results in convulsions, unconsciousness, and even death. Direct exposure to sun, poor air circulation, poor physical condition, and advanced age (over 40) increase the chance of heat stroke. Alcoholics are extremely susceptible. The symptoms of heat stroke are:

- Sudden onset;
- Dry, hot, and flushed skin;
- Dilated pupils;
- Early loss of consciousness;
- Full and fast pulse;
- Deep breathing at first, followed by shallow or faint breathing;
- Muscle twitching, growing into convulsions; and
- Body temperature reaching 105 to 106 degrees F or higher.

When providing emergency care for heat stroke, remember that it is a life-threatening emergency. Transportation to a medical facility should not be delayed. Move the patient to a cool environment, if possible, and remove as much clothing as possible. Ensure an open airway. Reduce body temperature promptly by dousing the body with water or, preferably, by wrapping the patient in a wet sheet. If cold packs are available, place them under the arms, around the neck, at the ankles, or any place where blood vessels that lie close to the skin can be cooled. Protect the patient from injury during convulsions.

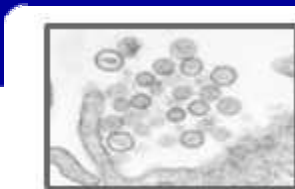
[CDC Home](#)[Search](#)[Health Topics A-Z](#)National Center for Infectious Diseases
Special Pathogens Branch

All About Hantaviruses

[All About Hantaviruses Home](#) | [General Information](#)
[Technical Information](#) | [Contact Us](#)

General Information

For general interest readers, students, and others
Printer-Friendly Version

[Back to General Information Index](#)

Tracking a Mystery Disease: A Brief History of Hantavirus Pulmonary Syndrome

When did we first hear about hantavirus? What has happened since the first cases made national headlines? Learn about how researchers from many different institutions joined together to hunt down the source of the deadly illness.

How Is the Virus That Causes HPS Transmitted? The Rodent Connection

Rodents, particularly the deer mouse and cotton rat, are the ultimate source of the disease. Learn how people get the virus from them!

Who Is at Risk of Getting HPS, and Why?

Find out who gets the disease and why. What does being "at risk" mean?

What are the Symptoms of HPS?

What signs and symptoms are important to know? What symptoms aren't?

How Do I Prevent HPS?

Prevention is your best bet for dealing with HPS. That means keeping rodents out of homes and workplaces, keeping away from rodents when camping or hiking, and cleaning up safely if you do find rodents. Our prevention pages have complete tips and instructions for all kinds of people, and all kinds of problems and concerns.

Treating Hantavirus Pulmonary Syndrome

There is no miracle drug to cure HPS. Instead, patients should get immediate intensive care. What does this involve?

Tracking a Mystery Disease: The Detailed Story of Hantavirus Pulmonary Syndrome

The "First" Outbreak

In May 1993, an outbreak of an unexplained pulmonary illness occurred in the southwestern United States, in an area shared by Arizona, New Mexico, Colorado and Utah known as "The Four Corners." A young, physically fit Navajo man suffering from shortness of breath was rushed to a hospital in New

Mexico and died very rapidly.

While reviewing the results of the case, medical personnel discovered that the young man's fiancée had died a few days before after showing similar symptoms, a piece of information that proved key to discovering the disease. As Dr. James Cheek of the Indian Health Service (IHS) noted, "I think if it hadn't been for that initial pair of people that became sick within a week of each other, we never would have discovered the illness at all."

An investigation combing the entire Four Corners region was launched by the New Mexico Office of Medical Investigations (OMI) to find any other people who had a similar case history. Within a few hours, Dr. Bruce Tempest of IHS, working with OMI, had located five young, healthy people who had all died after acute respiratory failure.

A series of laboratory tests had failed to identify any of the deaths as caused by a known disease, such as bubonic plague. At this point, the CDC Special Pathogens Branch was notified. CDC, the state health departments of New Mexico, Colorado and Utah, the Indian Health Service, the Navajo Nation, and the University of New Mexico all joined together to confront the outbreak.

During the next few weeks, as additional cases of the disease were reported in the Four Corners area, physicians and other scientific experts worked intensively to narrow down the list of possible causes. The particular mixture of symptoms and clinical findings pointed researchers away from possible causes, such as exposure to a herbicide or a new type of influenza, and toward some type of virus. Samples of tissue from patients who had gotten the disease were sent to CDC for exhaustive analysis. Virologists at CDC used several tests, including new methods to pinpoint virus genes at the molecular level, and were able to link the pulmonary syndrome with a virus, in particular a previously unknown type of hantavirus.

Researchers Launch Investigations to Pin Down the Carrier of the New Virus

Researchers knew that all other known hantaviruses were transmitted to people by rodents, such as mice and rats. Therefore, an important part of their mission was to trap as many different species of rodents living in the Four Corners region as possible to find the particular type of rodent that carried the virus. From June through mid-August of 1993, all types of rodents were trapped inside and outside homes where people who had hantavirus pulmonary syndrome had lived, as well as in piñon groves and summer sheep camps where they had worked. Additional rodents were trapped for comparison in and around nearby households as well. Taking a calculated risk, researchers decided not to wear protective clothing or masks during the trapping process. "We didn't want to go in wearing respirators, scaring...everybody," John Sarisky, an Indian Health Service environmental disease specialist said. However, when the almost 1,700 rodents trapped were dissected to prepare samples for analysis at CDC, protective clothing and respirators were worn.

Among rodents trapped, the deer mouse (*Peromyscus maniculatus*) was found to be the main host to a previously unknown type of hantavirus. Since the deer mouse often lives near people in rural and semi-rural areas—in barns and outbuildings, woodpiles, and inside people's homes—researchers suspected that the deer mouse might be transmitting the virus to humans. About 30% of the deer mice tested showed evidence of infection with hantavirus. Tests also showed that several other types of rodents were infected, although in lesser numbers.

The next step was to pin down the connection between the infected deer mice and households where people who had gotten the disease lived. Therefore, investigators launched a case-control investigation.

They compared "case" households, where people who had gotten the disease lived, with nearby "control" households. Control households were similar to those where the case-patients lived, except for one factor: no one in the control households had gotten the disease.

The results? First, investigators trapped more rodents in case households than in control households, so more rodents may have been living in close contact with people in case households. Second, people in case households were more likely than those in control households to do cleaning around the house or to plant in or hand-plow soil outdoors in fields or gardens. However, it was unclear if the risk for contracting HPS was due to performing these tasks, or with entering closed-up rooms or closets to get tools needed for these tasks.

In November 1993, the specific hantavirus that caused the Four Corners outbreak was isolated. The Special Pathogens Branch at CDC used tissue from a deer mouse that had been trapped near the New Mexico home of a person who had gotten the disease and grew the virus from it in the laboratory. Shortly afterwards and independently, the U.S. Army Medical Research Institute of Infectious Diseases (USAMRIID) also grew the virus, from a person in New Mexico who had gotten the disease as well as from a mouse trapped in California.

The new virus was called Muerto Canyon virus—later changed to Sin Nombre virus (SNV)—and the new disease caused by the virus was named hantavirus pulmonary syndrome, or HPS.

The isolation of the virus in a matter of months was remarkable. This success was based on close cooperation of all the agencies and individuals involved in investigating the outbreak, years of basic research on other hantaviruses that had been conducted at CDC and USAMRIID, and on the continuing development of modern molecular virologic tests. To put the rapid isolation of the Sin Nombre virus in perspective, it took several decades for the first hantavirus discovered, the Hantaan virus, to be isolated.

HPS Not Really a New Disease

As part of the effort to locate the source of the virus, researchers located and examined stored samples of lung tissue from people who had died of unexplained lung disease. Some of these samples showed evidence of previous infection with Sin Nombre virus—indicating that the disease had existed before the "first" known outbreak—it simply had not been recognized!

Other early cases of HPS have been discovered by examining samples of tissue belonging to people who had died of unexplained adult respiratory distress syndrome. By this method, the earliest known case of HPS that has been confirmed has been the case of a 38-year-old Utah man in 1959.

Interestingly, while HPS was not known to the epidemiologic and medical communities, there is evidence that it was recognized elsewhere. The Navajo Indians, a number of whom contracted HPS during the 1993 outbreak, recognize a similar disease in their medical traditions, and actually associate its occurrence with mice. As strikingly, Navajo medical beliefs concur with public health recommendations for preventing the disease.

Why Did the Outbreak Occur in the Four Corners Area?

But why this sudden cluster of cases? The key answer to this question is that, during this period, there were suddenly many more mice than usual. The Four Corners area had been in a drought for several years. Then, in early 1993, heavy snows and rainfall helped drought-stricken plants and animals to

revive and grow in larger-than-usual numbers. The area's deer mice had plenty to eat, and as a result they reproduced so rapidly that there were ten times more mice in May 1993 than there had been in May of 1992. With so many mice, it was more likely that mice and humans would come into contact with one another, and thus more likely that the hantavirus carried by the mice would be transmitted to humans.

Person-to-Person Spread of HPS Decided Unlikely

"Although person-to-person spread [of HPS] has not been documented with any of the other known hantaviruses, we were concerned [during this outbreak] because we were dealing with a new agent," said Charles Vitek, a CDC medical investigator.

Researchers and clinicians investigating the ongoing outbreak were not the only groups concerned about the disease. Shortly after the first few HPS patients died and it became clear that a new disease was affecting people in the area, and that no one knew how it was transmitted, the news media began extensive reporting on the outbreak. Widespread concern among the public ensued.

Unfortunately, the first victims of the outbreak were Navajo. News reports focused on this fact, and the misperception grew that the unknown disease was somehow linked to Navajos. As a consequence, Navajos found themselves at the center of intense media attention and the objects of the some people's fears.

By later in the summer of 1993, the media frenzy had quieted somewhat, and the source of the disease was pinpointed. Researchers determined that, like other hantaviruses, the virus that causes HPS is not transmitted from person to person the way other infections, such as the common cold, may be.

To date, no cases of HPS have been reported in the United States in which the virus was transmitted from one person to another. In fact, in a study of health care workers who were exposed to either patients or specimens infected with related types of hantaviruses (which cause a different disease in humans), none of the workers showed evidence of infection or illness.

HPS Since the First Outbreak

After the initial outbreak, the medical community nationwide was asked to report any cases of illness with symptoms similar to those of HPS that could not be explained by any other cause. As a result, additional cases have been reported.

Since 1993, researchers have discovered that there is not just one hantavirus that causes HPS, but several. In June 1993, a Louisiana bridge inspector who had not traveled to the Four Corners area developed HPS. An investigation was begun. The patient's tissues were tested for the presence of antibodies to hantavirus. The results led to the discovery of another hantavirus, named Bayou virus, which was linked to a carrier, the rice rat (*Oryzomys palustris*). In late 1993, a 33-year-old Florida man came down with HPS symptoms; he later recovered. This person also had not traveled to the Four Corners area. A similar investigation revealed yet another hantavirus, named the Black Creek Canal virus, and its carrier, the cotton rat (*Sigmodon hispidus*). Another case occurred in New York. This time, the Sin Nombre-like virus was named New York-1, and the white-footed mouse, *Peromyscus leucopus*, was implicated as the carrier.

More recently, cases of HPS stemming from related hantaviruses have been documented in Argentina,

Brazil, Canada, Chile, Paraguay, and Uruguay, making HPS a pan-hemispheric disease.

References

Information for this page was developed using the CDC video *Preventing Hantavirus Disease* and resource articles listed in the bibliography.

How Is Hantavirus Transmitted?

In the United States, deer mice (along with cotton rats and rice rats in the southeastern states and the white-footed mouse in the Northeast) carry hantaviruses that cause hantavirus pulmonary syndrome. Learn more about the rodent carriers of HPS.

Rodents shed the virus in their urine, droppings, and saliva. The virus is mainly transmitted to people when they breathe in air contaminated with the virus.

When fresh rodent urine, droppings or nesting materials are stirred up, tiny droplets containing the virus get into the air. This process is known as "aerosolization."

There are several other ways rodents may spread hantavirus to people:

- If a rodent with the virus bites someone, the virus may be spread to that person-but this type of transmission is rare.
- Researchers believe that people may be able to get the virus if they touch something that has been contaminated with rodent urine, droppings, or saliva, and then touch their nose or mouth.
- Researchers also suspect people can become sick if they eat food contaminated by urine, droppings, or saliva from an infected rodent.

Can You Get Hantavirus from Another Person?

The types of hantavirus that cause HPS in the United States cannot be transmitted from one person to another. For example, you cannot get the virus from touching or kissing a person who has HPS or from a health care worker who has treated someone with the disease. You also cannot get the virus from a blood transfusion in which the blood came from a person who became ill with HPS and survived.

Can You Get Hantavirus from Animals Other Than Rodents, or from Insects? What About Pets?

No-the hantaviruses that cause HPS in the United States are not known to be transmitted by any types of animals other than certain species of rodents. You cannot get hantavirus from farm animals, such as cows, chickens, or sheep, or from insects, such as mosquitoes. Dogs and cats are not known to carry hantavirus; however, they may bring infected rodents into contact with people if they catch such animals and carry them home. Guinea pigs, hamsters, gerbils, and rodents from pet stores are not known to carry hantavirus.

Here are the Rodents That Carry the Types of Hantavirus Which Cause HPS in the United States:



deer mouse

The Deer Mouse (*Peromyscus maniculatus*) is a deceptively cute animal, with big eyes and big ears. Its head and body are normally about 2 - 3 inches long, and the tail adds another 2 - 3 inches in length. You may see it in a variety of colors, from gray to reddish brown, depending on its age. The underbelly is always white and the tail has sharply defined white sides. The deer mouse is found almost everywhere in North America. Usually, the deer mouse likes woodlands, but also turns up in desert areas.



cotton rat

The Cotton Rat (*Sigmodon hispidus*), which you'll find in the southeastern United States (and way down into Central and South America), has a bigger body than the deer mouse—head and body about 5 - 7 inches, and another 3 - 4 inches for the tail. The hair is longer and coarser, of a grayish brown color, even grayish black. The cotton rat prefers overgrown areas with shrubs and tall grasses.

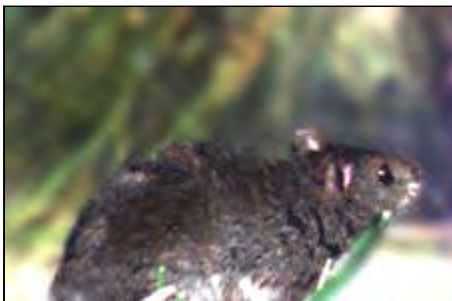

rice rat

The Rice Rat (*Oryzomys palustris*) is slightly smaller than the cotton rat, having a head and body 5 - 6 inches long, plus a very long, 4- to 7-inch tail. Rice rats sport short, soft, grayish brown fur on top, and gray or tawny underbellies. Their feet are whitish. As you might expect from the name, this rat likes marshy areas and is semiaquatic. It's found in the southeastern United States and in Central America.



white-footed mouse

The White-footed Mouse (*Peromyscus leucopus*) is hard to distinguish from the deer mouse. The head and body together are about four inches long. Note that its tail is normally shorter than its

body (about 2 - 4 inches long). Topside, its fur ranges from pale brown to reddish brown, while its underside and feet are white. The white-footed mouse is found through southern New England, the Mid-Atlantic and southern states, the midwestern and western states, and Mexico. It prefers wooded and brushy areas, although sometimes it will live in more open ground.

Both the deer mouse and the cotton rat usually live in rural areas, but can also be found in cities when conditions are right, such as easy availability of food, water and shelter. (Remember this point when it comes to "discouraging" rodents, which is discussed under "How Do I Prevent HPS").

Other Rodents May Also Carry Hantavirus

Other rodents carry strains of hantavirus that cause HPS, but they have not yet been identified. In addition, other rodent species may play host to other types of hantaviruses that cause a different type of infection, hemorrhagic fever with renal syndrome, or HFRS. See "hantavirus" for more information.

It is wise, therefore, to avoid close contact with rodents in general.

Transmission Details: So How Does "Aerosolization" Really Work?

For a hantavirus to cause HPS, the virus must travel from the rodents that carry it to a person. A common way this happens is when a person breathes in the hantavirus from the air.

Let's create an imaginary scenario and go through the process step by step. Say you have a storage room in your home that you hardly ever enter. You keep old furniture there, old newspapers and magazines, and so on. At some point, a group of deer mice find their way into the room, looking for places to build nests. They found their way into the room through a crack—deer mice can squeeze through holes as small as a shirt button! Some mice chew through the fabric of an old armchair and build a nest inside it. Other mice shred bits of magazines and build nests under the shredded pieces.

A few of these mice are infected with the hantavirus. The infected mice don't show any signs of being sick. In fact, the virus does not seem to make them ill at all; it simply lives in their bodies. However, the virus is shed continuously from them: into the droppings and urine they leave around the room, and into their saliva, which dries on anything they have chewed, such as nesting material. Out in the environment like this, the virus can live for several days.

Meanwhile, you decide to clean up your storage room. You go inside, spend a few minutes moving boxes and furniture. The mice hear you coming and scurry away, leaving a trail of fresh urine! Because you find mouse droppings and some of the furniture stuffing the mice have used as nesting material, you get a broom and sweep up the mess. As you move around and sweep, tiny particles of fresh urine, droppings and saliva, with the virus in them, get kicked up into the air. This is the aerosolization. It is these tiny particles that you breathe in—and this is the beginning of becoming sick with HPS.

Because the virus is spread when virus-containing particles are stirred up into the air, an essential HPS tactic in areas showing signs of rodents is to avoid actions that raise dust and to carefully wet the area

down with disinfectant. The less chance the virus has to get into the air, the less chance it will be breathed in!

Who Is at Risk of Getting HPS, and Why?

Anyone who comes into contact with rodents that carry hantavirus is at risk of HPS. Rodent infestation in and around the home remains the primary risk for hantavirus exposure. Even healthy individuals are at risk for HPS infection if exposed to the virus.

What Kind of Activities Are Risky?

Any activity that puts you in contact with rodent droppings, urine, saliva, or nesting materials can place you at risk for infection. Hantavirus is spread when virus-containing particles from rodent urine, droppings, or saliva are stirred into the air. It is important to avoid actions that raise dust, such as sweeping or vacuuming. Infection occurs when you breathe in virus particles.

Opening and Cleaning Previously Unused Buildings

Opening or cleaning cabins, sheds, and outbuildings, including barns, garages and storage facilities, that have been closed during the winter is a potential risk for hantavirus infections, especially in rural settings.

Housecleaning Activities

Cleaning in and around your own home can put you at risk if rodents have made it their home too. Many homes can expect to shelter rodents, especially as the weather turns cold. Please see our prevention information on how to properly clean rodent-infested areas.

Work-related Exposure

Construction, utility and pest control workers can be exposed when they work in crawl spaces, under houses, or in vacant buildings that may have a rodent population.

Campers and Hikers

Campers and hikers can also be exposed when they use infested trail shelters or camp in other rodent habitats.

The chance of being exposed to hantavirus is greatest when people work, play, or live in closed spaces where rodents are actively living. However, recent research results show that many people who have become ill with HPS were infected with the disease after continued contact with rodents and/or their droppings. In addition, many people who have contracted HPS reported that they had not seen rodents or their droppings before becoming ill. Therefore, if you live in an area where the carrier rodents, such as the deer mouse, are known to live, take sensible precautions-even if you do not see rodents or their droppings.

What Are The Symptoms of HPS?

Early symptoms

Early symptoms include fatigue, fever and muscle aches, especially in the large muscle groups-thighs, hips, back, and sometimes shoulders. These symptoms are universal.

There may also be headaches, dizziness, chills, and abdominal problems, such as nausea, vomiting, diarrhea, and abdominal pain. About half of all HPS patients experience these symptoms.

Late symptoms

Four to 10 days after the initial phase of illness, the late symptoms of HPS appear. These include coughing and shortness of breath, with the sensation of, as one survivor put it, a "...tight band around my chest and a pillow over my face" as the lungs fill with fluid.

Uncommon symptoms

Earache, sore throat, runny nose, and rash are very uncommon symptoms of HPS.

How long after contracting the virus do symptoms appear?

Due to the small number of HPS cases, the "incubation time" is not positively known. However, on the basis of limited information, it appears that symptoms may develop between 1 and 5 weeks after exposure to urine, droppings, or saliva of infected rodents.

Another important point to remember from the data that the CDC Special Pathogens Branch keeps on all reported cases of HPS, is that it appears many people who have become ill were in a situation where they did not see rodents or rodent droppings. Other people have had frequent contact with rodents and their droppings before becoming ill. This apparent inconsistency makes it very difficult to pin down the precise time when the virus was transmitted.

How Do I Prevent HPS?

Eliminate or minimize contact with rodents in your home, workplace, or campsite. If rodents don't find that where you are is a good place for them to be, then you're less likely to come into contact with them. Seal up holes and gaps in your home or garage. Place traps in and around your home to decrease rodent infestation. Clean up any easy-to-get food.

Recent research results show that many people who became ill with HPS developed the disease after having been in frequent contact with rodents and/or their droppings around a home or a workplace. On the other hand, many people who became ill reported that they had not seen rodents or rodent droppings at all. Therefore, if you live in an area where the carrier rodents are known to live, try to keep your home, vacation place, workplace, or campsite clean.

Prevention Indoors and Outdoors

Indoors:

- Keep a clean home, especially kitchen (wash dishes, clean counters and floor, keep food covered in rodent-proof containers).
- Keep a tight-fitting lid on garbage, discard uneaten pet food at the end of the day.
- Set and keep spring-loaded rodent traps. Set traps near baseboards because rodents tend to run along walls and in tight spaces rather than out in the open.
- Set Environmental Protection Agency-approved rodenticide with bait under plywood or plastic shelter along baseboards. These are sometimes known as "covered bait stations." Remember to follow product use instructions carefully, since rodenticides are poisonous to pets and people, too.
- Seal all entry holes 1/4 inch wide or wider with lath screen or lath metal, cement, wire screening or other patching materials, inside and out.

If bubonic plague is a problem in your area, spray flea killer or spread flea powder in the area before setting traps. This is important. If you control rodents but do not control fleas as well, you may increase the risk of infection with bubonic plague, since fleas will leave rodents once the rodents die and will seek out other food sources, including humans.

Outdoors:

- Clear brush, grass and junk from around house foundations to eliminate a source of nesting materials.
- Use metal flashing around the base of wooden, earthen or adobe homes to provide a strong metal barrier. Install so that the flashing reaches 12 inches above the ground and six inches down into the ground.
- Elevate hay, woodpiles and garbage cans to eliminate possible nesting sites. If possible, locate them 100 feet or more from your house.
- Trap rodents outside, too. Poisons or rodenticides may be used as well, but be sure to keep them out of the reach of children or pets.
- Encourage the presence of natural predators, such as non-poisonous snakes, owls and hawks.
- Remember, getting rid of all rodents isn't feasible, but with ongoing effort you can keep the population very low.

Some Common Signs of Rodent Infestation

Remember that not all types of rodents carry hantavirus. Neither common house mice nor common rats have been associated with HPS in humans, for example. Yet because it can be tough to tell just what kind of rodents you have, play it safe -- clean up the infestation and rodent-proof your home or workplace.

Here are some common signs that you may have a rodent problem.

Rodent Droppings

This is one of the most reliable signs that you have a rodent problem. You may find droppings in places where you store your food or your pet/animal food, such as in cupboards and drawers or in bins. Because mice like to run in places that offer them some protection from predators, you may find droppings in cupboards or under the sink, along walls, or on top of wall studs or beams. Mice will leave droppings near their nests as well (see below). Storage rooms, sheds, barns, or cabins loaded with boxes, bags, old furniture, and other objects make an ideal home for rodents, so you may find droppings there, even inside boxes and other containers.

Workplaces can also make good rodent homes. Warehouses, restaurants, and the like are obvious places to look because food may be plentiful there. However, rodents can infest office buildings, too. Once again, look for droppings in protected places, such as closets, storage rooms, or inside boxes.

Signs of Rodent Nests

Rodents tend to build their nests from materials that are soft, fuzzy, or warm. Among common rodent nest materials are shredded paper, bunches of dry grass or small twigs, fabric, and furniture stuffing. Rodents will nest wherever safety from enemies can be found close enough to food and water, and they prefer places that are relatively quiet. Inside buildings, here are some places to look:

- inside cabinets
- under or inside dressers
- in and among boxes
- behind and inside machinery and appliances (kitchen appliances such as stoves or refrigerator drip pans; water coolers; and electric motor cases or computer cases)
- inside upholstered furniture
- inside double walls or the space between floors and ceilings.

Food Boxes, Containers, or Food Itself That Appears To Be Nibbled

Look for droppings nearby. Rodents can chew through plastic, so plastic bags do not make safe food storage containers.

Signs of Rodent "Feeding Stations"

These are semi-hidden spots where rodents eat food they have collected. At these stations, rodents may leave larger-than-normal amounts of droppings/urine, plus remnants of a variety of foods (such as nut shells), bits of plastic or paper, and cockroach carcasses.

You Find Evidence of Gnawing

To get to food, rodents will gnaw on almost anything that is softer than the enamel of their teeth. This includes such things as wood, paper board, cloth sacks, and materials even harder than these. Because rodents' teeth grow continuously, they must gnaw to keep them short. That may help to explain why chair legs or similar surfaces show gnawed spots or tooth marks in rodent-infested places.

You Notice an Odd, Stale Smell

In closed-up rooms infested by rodents, you will commonly smell an unusual, musky odor.

You See a Mouse in Your House

Rodents are normally active at night, and generally avoid humans. If you have rodents, unless the infestation is large, you may never see one.

Clean Up Infested Areas, Using Safety Precautions:

Put on latex rubber gloves before cleaning up.

Do not stir up dust by sweeping up or vacuuming up droppings, urine or nesting materials.

Instead, thoroughly wet contaminated areas with detergent or liquid to deactivate the virus. Most general purpose disinfectants and household detergents are effective. However, a hypochlorite solution prepared by mixing 1 and 1/2 cups of household bleach in 1 gallon of water may be used in place of commercial disinfectant. When using the chlorine solution, avoid spilling the mixture on clothing or other items that may be damaged.

Once everything is wet, take up contaminated materials with a damp towel, then mop or sponge the area with disinfectant.

Spray dead rodents with disinfectant, then double-bag along with all cleaning materials and bury or burn—or throw out in appropriate waste disposal system. If burning or burying isn't feasible, contact your local or state health department about other disposal methods.

Finally, disinfect gloves *before taking them off* with disinfectant or soap and water. After taking off the clean gloves, thoroughly wash hands with soap and warm water.

When going into cabins or outbuildings (or work areas) that have been closed for awhile, open them up and air out before cleaning.

Hantaviruses and Disinfectants

Hantaviruses are surrounded by a lipid (fatty) envelope, so they are somewhat fragile. The lipid envelope can be destroyed and the virus killed by fat solvents, such as alcohol, ordinary disinfectants and household bleach. That is why one of the most important ways to prevent transmitting the disease is to carefully wet down dead rodents and areas where rodents have been with disinfectant and/or bleach. When you do this, you are killing the virus itself and reducing the chance that the virus will get into the air.

[Strength and Quantity of Hypochlorite Solutions \(Bleach\)](#)

Special Pathogens Branch recommends a 10% bleach solution be used to inactivate hantaviruses.

Special Precautions for Homes of Persons with Confirmed Hantavirus Infection or Buildings with Heavy Rodent Infestations

Special precautions should be used for cleaning homes or buildings with heavy rodent infestations in areas where HPS has been reported. If you are attempting to deal with such an infestation, it is recommended that you contact the responsible local, state, or federal public health agency for guidance.

The special precautions may also apply to vacant dwellings that have attracted numbers of rodents while unoccupied and to dwellings and other structures that have been occupied by persons with confirmed hantavirus infection.

Workers who are either hired specifically to perform the clean-up or asked to do so as part of their work activities should receive a thorough orientation from the responsible health agency about hantavirus transmission and should be trained to perform the required activities safely.

Precautions To Be Used:

- Persons involved in the clean-up should wear coveralls (disposable, if possible), rubber boots or disposable shoe covers, rubber or plastic gloves, protective goggles, and an appropriate respiratory protection device, such as a half-mask air-purifying (or negative-pressure) respirator with a high-efficiency particulate air (HEPA) filter or a powered air-purifying respirator (PAPR) with HEPA filters.

Please note: the HEPA classification recently has been discontinued. Please read "Update On the Nomenclature and Use of Respirators as a Precaution for Hantavirus Infection, February, 1999" for details.

- Personal protective gear should be decontaminated upon removal at the end of the day. If the coveralls are not disposable, they should be laundered on site. If no laundry facilities are available, the coveralls should be immersed in liquid disinfectant until they can be washed.
 - All potentially infective waste material (including respirator filters) from clean-up operations that cannot be burned or deep buried on site should be double bagged in appropriate plastic bags. The bagged material should then be labeled as infectious (if it is to be transported) and disposed of in accordance with local requirements for infectious waste.
 - Workers who develop symptoms suggestive of HPS within 45 days of the last potential exposure should immediately seek medical attention. The physician should contact local health authorities promptly if hantavirus-associated illness is suspected. A blood sample should be obtained and forwarded with the baseline serum through the state health department to CDC for hantavirus antibody testing.
-

Precautions for Workers in Affected Areas Who are Regularly Exposed to Rodents

Persons who frequently handle or are exposed to rodents (e.g., mammalogists, pest-control workers) in the affected area are probably at higher risk for hantavirus infection than the general public because of their frequency of exposure. Therefore, enhanced precautions are warranted to protect them against

hantavirus infection.

Precautions To Be Used:

- Workers in potentially high-risk settings should be informed about the symptoms of the disease and be given detailed guidance on prevention measures.
- Workers who develop a febrile or respiratory illness within 45 days of the last potential exposure should immediately seek medical attention and inform the attending physician of the potential occupational risk of hantavirus infection. The physician should contact local health authorities promptly if hantavirus-associated illness is suspected. A blood sample should be obtained and forwarded with the baseline serum through the state health department to CDC for hantavirus antibody testing.
- Workers should wear a half-face air-purifying (or negative-pressure) respirator or PAPR equipped with HEPA filters when removing rodents from traps or handling rodents in the affected area. (Please note: the HEPA classification recently has been discontinued. Under the new classification system, the N-100 filter type is recommended. Read the Federal Occupational Safety and Health Administration (OSHA) directive online, at "OSHA Directives: CPL 2-0.120 - Inspection procedures for the Respiratory Protection Standard".), at http://www.osha.gov/pls/oshaweb/owadisp.show_document?p_table=DIRECTIVES&p_id=2275
- Respirators (including positive-pressure types) are not considered protective if facial hair interferes with the face seal, since proper fit cannot be assured. Respirator use practices should be in accord with a comprehensive user program and should be supervised by a knowledgeable person.
- Workers should wear rubber or plastic gloves when handling rodents or handling traps containing rodents. Gloves should be washed and disinfected before removing them, as described above.
- Traps contaminated by rodent urine or feces or in which a rodent was captured should be disinfected with a commercial disinfectant or bleach solution. Dispose of dead rodents as described in the section on Eliminating Rodents inside the Home.
- Persons removing organs or obtaining blood from rodents in affected areas should contact the Special Pathogens Branch, Division of Viral and Rickettsial Diseases, National Center for Infectious Diseases, Centers for Disease Control and Prevention, [telephone (404) 639-1115] for detailed safety precautions.

Precautions for Other Occupational Groups Who Have Potential Rodent Contact

Insufficient information is available at this time to allow general recommendations regarding risks or precautions for persons in the affected areas who work in occupations with unpredictable or incidental contact with rodents or their habitations. Examples of such occupations include telephone installers, maintenance workers, plumbers, electricians, and certain construction workers. Workers in these jobs may have to enter various buildings, crawl spaces, or other sites that may be rodent infested. Recommendations for such circumstances must be made on a case-by-case basis after the specific working environment has been assessed and state or local health departments have been consulted.

Precautions for Campers and Hikers in the Affected Areas

There is no evidence to suggest that travel into areas where HPS has been reported should be restricted. Most usual tourist activities pose little or no risk that travelers will be exposed to rodents or their urine and/or droppings.

However, persons who do outdoor activities such as camping or hiking in areas where the disease has been reported should take precautions to reduce the likelihood of their exposure to potentially infectious materials.

Useful Precautions:

- Avoid coming into contact with rodents and rodent burrows or disturbing dens (such as pack rat nests).
 - Air out, then disinfect cabins or shelters before using them. These places often shelter rodents.
 - Do not pitch tents or place sleeping bags in areas in proximity to rodent droppings or burrows or near areas that may shelter rodents or provide food for them (e.g., garbage dumps or woodpiles).
 - If possible, do not sleep on the bare ground. In shelters, use a cot with the sleeping surface at least 12 inches above the ground. Use tents with floors or a ground cloth if sleeping in the open air.
 - Keep food in rodent-proof containers!
 - Promptly bury (or--preferably--burn followed by burying, when in accordance with local requirements) all garbage and trash, or discard in covered trash containers.
 - Use only bottled water or water that has been disinfected by filtration, boiling, chlorination, or iodination for drinking, cooking, washing dishes, and brushing teeth.
 - And last but not least, do not play with or handle any rodents that show up at the camping or hiking site, even if they appear friendly.
-

Update On the Nomenclature and Use of Respirators as a Precaution for Hantavirus Infection February, 1999

The CDC **Interim Recommendations for Risk Reduction for Hantavirus Infection**(1) describe precautions for persons who are involved in the cleanup of homes of confirmed cases of hantavirus infection or of areas with heavy rodent infestation and for workers in affected areas who are regularly exposed to rodents. Among these precautions is the wearing of one of the following types of respirators (2) equipped with a high-efficiency particulate air (HEPA) filter:



a) half-mask air-purifying (or negative-pressure) respirator

Recent changes in the nomenclature and certification of the type of filters used in these respirators include the **discontinuation of the HEPA designation** and the designation of new classes of filters. As shown on the chart below, the N-100 (99.97) is equivalent to the previous HEPA filter.

Use of an N-100 filter should provide the same protection as the HEPA filter. Due to the nature of the virus, no studies have been able to test the



b) powered air-purifying respirator (PAPR)

efficacy of either the HEPA or N-100 filters in protecting against HPS transmission. Available evidence suggests that HPS is transmitted by inspiring small (less than 5 micron) viral particles in aerosols which the N-100 is the most effective in removing.

Cautions: As described in CDC **Interim Recommendations for Risk Reduction for Hantavirus Infection**, all negative-pressure respirators are fit-dependent. Anything that interferes with the respirator's face seal, such as facial hair, will allow ambient air to bypass the filter medium in the respirator(3). Ideally, users should be fit-tested with the same make, model, style, and size of respirator that will be actually used. Respirator

practices should follow a comprehensive user program and be supervised by a knowledgeable person.

New Classes of Filters for Respiratory Protection Devices(4)

<i>New classes of filters ††</i>			<i>Characteristics</i>
			Equivalent to HEPA
N-95	N-99	N-100 (99.97)	Not resistant to oil
R-95	R-99	R-100 (99.97)	Resistant to oil
P-95	P-99	P-100 (99.97)	Oil Proof

†† number indicates % efficiency in removing monodispersed particles 0.3 micrometers in diameter.

Authority for testing and certifying these respirators has been given exclusively to NIOSH. For additional information:

- contact the Industrial Hygiene Section, Office of Health & Safety, CDC at 404 639-3112.
- Read the NIOSH directive online, at "OSHA Directives: CPL 2-0.120 - Inspection procedures for the Respiratory Protection Standard", at http://www.osha.gov/pls/oshaweb/owadisp.show_document?p_table=DIRECTIVES&p_id=2275

(1) *MMWR* Recommendations and Reports, July 30, 1993; 42 [RR-11]: 1-13)

(2) All of these respirators can be purchased from commercial suppliers of laboratory safety equipment. The items displayed here are intended to show the general design of the respirator and do not constitute endorsement of any particular brand of respirator.

(3) *MMWR* 47(40): 1045-1049, demonstrates importance of fit testing for all negative-pressure respirators.

(4) As described in NIOSH 42, CFR 84.

What Is the Treatment for HPS?

At the present time, there is no specific treatment or "cure" for hantavirus infection. However, we do know that if the infected individuals are recognized early and are taken to an intensive care unit, some patients may do better. In intensive care, patients are intubated and given oxygen therapy to help them through the period of severe respiratory distress.

The earlier the patient is brought in to intensive care, the better. If a patient is experiencing full distress, it is less likely the treatment will be effective.

Therefore, if you have been around rodents and have symptoms of fever, deep muscle aches and severe shortness of breath, see your doctor *immediately*. Be sure to tell your doctor that you have been around rodents—this will alert your physician to look closely for any rodent-carried disease such as HPS.

[Back to General Information Index](#)

[All About Hantaviruses Home](#) | [General Information](#) | [Technical Information](#) | [Contact Us](#)

[CDC Home](#) | [Search](#) | [Health Topics A-Z](#)

This page last reviewed Thursday, April 28, 2005

Infectious Disease Pathology Activity
Division of Viral and Rickettsial Diseases
National Center for Infectious Diseases
[Centers for Disease Control and Prevention](#)
U.S. Department of Health and Human Services





Appendix B: Hospital Map/Route to Hospital





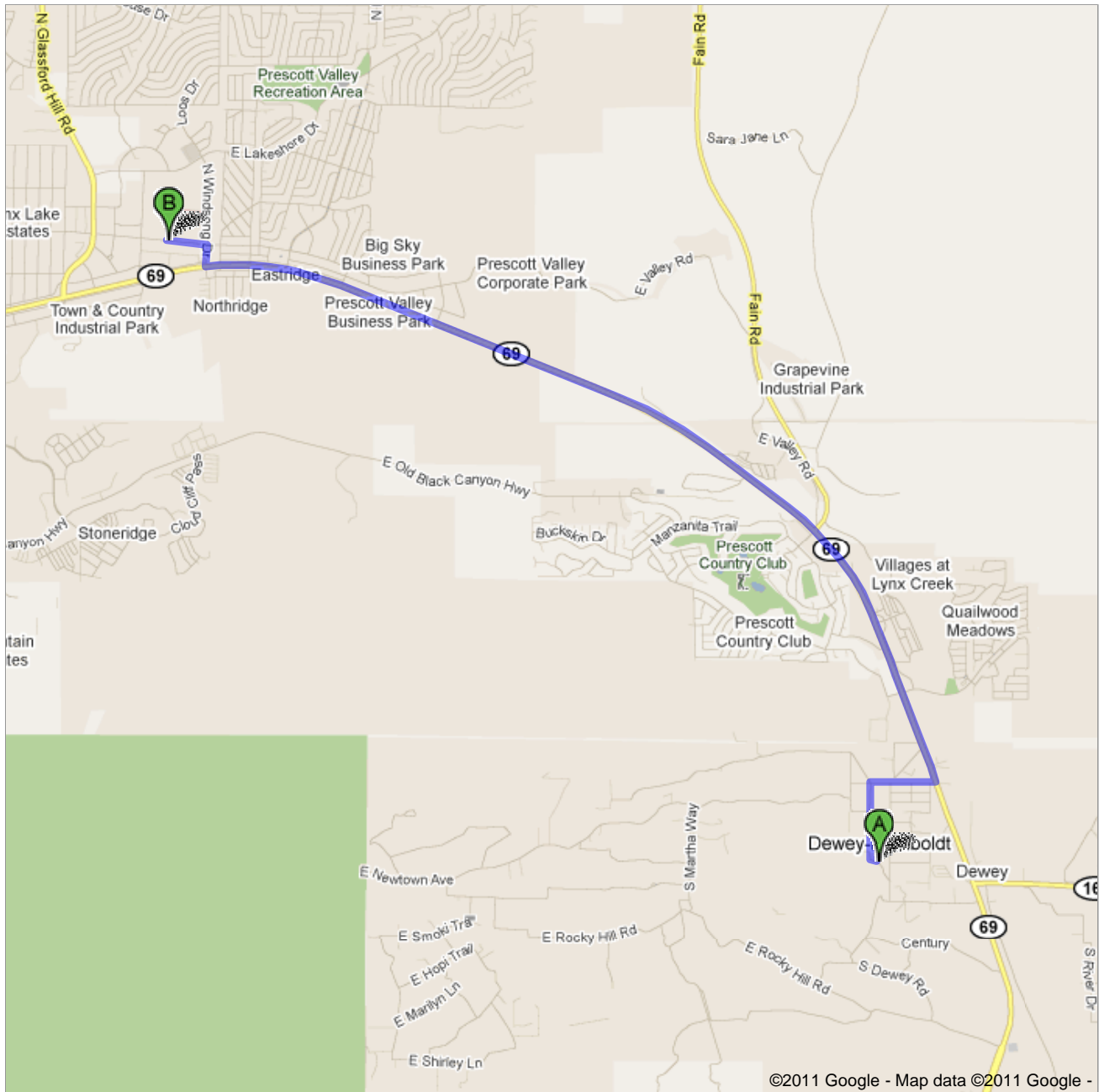

Directions to 7700 E Florentine Rd, Prescott Valley, AZ 86314
7.3 mi – about 13 mins

Route to Hospital
Yavapai Regional Medical Center - East



 Dewey-Humboldt, AZ

-
1. Head **northwest** on **Antelope Dr/E Deer Path Rd** toward **Yavapai Dr**
Continue to follow Antelope Dr
About 2 mins go 0.5 mi
total 0.5 mi
 -  2. Take the 3rd right onto **Kachina Pl**
About 1 min go 0.4 mi
total 0.9 mi
 -  3. Take the 1st left onto **AZ-69 N**
About 9 mins go 6.0 mi
total 6.9 mi
 -  4. Turn right at **N Windsong Dr**
go 0.1 mi
total 7.1 mi
 -  5. Turn left at **E Florentine Rd**
Destination will be on the right
About 1 min go 0.3 mi
total 7.3 mi

 7700 E Florentine Rd, Prescott Valley, AZ 86314

These directions are for planning purposes only. You may find that construction projects, traffic, weather, or other events may cause conditions to differ from the map results, and you should plan your route accordingly. You must obey all signs or notices regarding your route.

Map data ©2011 Google

Directions weren't right? Please find your route on maps.google.com and click "Report a problem" at the bottom left.

C Standard Operating Procedures



U. S. EPA ENVIRONMENTAL RESPONSE TEAM

STANDARD OPERATING PROCEDURES

SOP: 2012
PAGE: 2 of 13
REV: 0.0
DATE: 02/18/00

SOIL SAMPLING

1.0 SCOPE AND APPLICATION

The purpose of this standard operating procedure (SOP) is to describe the procedures for the collection of representative soil samples. Sampling depths are assumed to be those that can be reached without the use of a drill rig, direct-push, or other mechanized equipment (except for a back-hoe). Analysis of soil samples may determine whether concentrations of specific pollutants exceed established action levels, or if the concentrations of pollutants present a risk to public health, welfare, or the environment.

These are standard (i.e., typically applicable) operating procedures which may be varied or changed as required, dependent upon site conditions, equipment limitations or limitations imposed by the procedure. In all instances, the actual procedures used should be documented and described in an appropriate site report.

Mention of trade names or commercial products does not constitute U.S. Environmental Protection Agency (EPA) endorsement or recommendation for use.

2.0 METHOD SUMMARY

Soil samples may be collected using a variety of methods and equipment depending on the depth of the desired sample, the type of sample required (disturbed vs. undisturbed), and the soil type. Near-surface soils may be easily sampled using a spade, trowel, and scoop. Sampling at greater depths may be performed using a hand auger, continuous flight auger, a trier, a split-spoon, or, if required, a backhoe.

3.0 SAMPLE PRESERVATION, CONTAINERS, HANDLING, AND STORAGE

Chemical preservation of solids is not generally recommended. Samples should, however, be cooled and protected from sunlight to minimize any potential reaction. The amount of sample to be collected and proper sample container type are discussed in ERT/REAC SOP #2003 Rev. 0.0 08/11/94, *Sample Storage, Preservation and Handling*.

4.0 INTERFERENCES AND POTENTIAL PROBLEMS

There are two primary potential problems associated with soil sampling - cross contamination of samples and improper sample collection. Cross contamination problems can be eliminated or minimized through the use of dedicated sampling equipment. If this is not possible or practical, then decontamination of sampling equipment is necessary. Improper sample collection can involve using contaminated equipment, disturbance of the matrix resulting in compaction of the sample, or inadequate homogenization of the samples where required, resulting in variable, non-representative results.

5.0 EQUIPMENT



U. S. EPA ENVIRONMENTAL RESPONSE TEAM

STANDARD OPERATING PROCEDURES

SOP: 2012
PAGE: 3 of 13
REV: 0.0
DATE: 02/18/00

SOIL SAMPLING

Soil sampling equipment includes the following:

- ☐ Maps/plot plan
- ☐ Safety equipment, as specified in the site-specific Health and Safety Plan
- ☐ Survey equipment or global positioning system (GPS) to locate sampling points
- ☐ Tape measure
- ☐ Survey stakes or flags
- ☐ Camera and film
- ☐ Stainless steel, plastic, or other appropriate homogenization bucket, bowl or pan
- ☐ Appropriate size sample containers
- ☐ Ziplock plastic bags
- ☐ Logbook
- ☐ Labels
- ☐ Chain of Custody records and custody seals
- ☐ Field data sheets and sample labels
- ☐ Cooler(s)
- ☐ Ice
- ☐ Vermiculite
- ☐ Decontamination supplies/equipment
- ☐ Canvas or plastic sheet
- ☐ Spade or shovel
- ☐ Spatula
- ☐ Scoop
- ☐ Plastic or stainless steel spoons
- ☐ Trowel(s)
- ☐ Continuous flight (screw) auger
- ☐ Bucket auger
- ☐ Post hole auger
- ☐ Extension rods
- ☐ T-handle
- ☐ Sampling trier
- ☐ Thin wall tube sampler
- ☐ Split spoons
- ☐ Vehimeyer soil sampler outfit
 - Tubes
 - Points
 - Drive head
 - Drop hammer
 - Puller jack and grip
- ☐ Backhoe



U. S. EPA ENVIRONMENTAL RESPONSE TEAM

STANDARD OPERATING PROCEDURES

SOP: 2012
PAGE: 4 of 13
REV: 0.0
DATE: 02/18/00

SOIL SAMPLING

Reagents are not used for the preservation of soil samples. Decontamination solutions are specified in ERT/REAC SOP #2006 Rev. 0.0 08/11/94, *Sampling Equipment Decontamination*, and the site specific work plan.

7.0 PROCEDURES

7.1 Preparation

1. Determine the extent of the sampling effort, the sampling methods to be employed, and the types and amounts of equipment and supplies required.
2. Obtain necessary sampling and monitoring equipment.
3. Decontaminate or pre-clean equipment, and ensure that it is in working order.
4. Prepare schedules and coordinate with staff, client, and regulatory agencies, if appropriate.
5. Perform a general site survey prior to site entry in accordance with the site specific Health and Safety Plan.
6. Use stakes, flagging, or buoys to identify and mark all sampling locations. Specific site factors, including extent and nature of contaminant, should be considered when selecting sample location. If required, the proposed locations may be adjusted based on site access, property boundaries, and surface obstructions. All staked locations should be utility-cleared by the property owner or the On-Scene-Coordinator (OSC) prior to soil sampling; and utility clearance should always be confirmed before beginning work.

7.2 Sample Collection

7.2.1 Surface Soil Samples

Collection of samples from near-surface soil can be accomplished with tools such as spades, shovels, trowels, and scoops. Surface material is removed to the required depth and a stainless steel or plastic scoop is then used to collect the sample.

This method can be used in most soil types but is limited to sampling at or near the ground surface. Accurate, representative samples can be collected with this procedure depending on the care and precision demonstrated by the sample team member. A flat, pointed mason trowel to cut a block of the desired soil is helpful when undisturbed profiles are required. Tools plated with chrome or other materials should not be used. Plating is particularly common with garden implements such as potting trowels.

The following procedure is used to collect surface soil samples:



U. S. EPA ENVIRONMENTAL RESPONSE TEAM

STANDARD OPERATING PROCEDURES

SOP: 2012
PAGE: 5 of 13
REV: 0.0
DATE: 02/18/00

SOIL SAMPLING

1. Carefully remove the top layer of soil or debris to the desired sample depth with a pre-cleaned spade.
2. Using a pre-cleaned, stainless steel scoop, plastic spoon, or trowel, remove and discard a thin layer of soil from the area which came in contact with the spade.
3. If volatile organic analysis is to be performed, transfer the sample directly into an appropriate, labeled sample container with a stainless steel lab spoon, or equivalent and secure the cap tightly. Place the remainder of the sample into a stainless steel, plastic, or other appropriate homogenization container, and mix thoroughly to obtain a homogenous sample representative of the entire sampling interval. Then, either place the sample into appropriate, labeled containers and secure the caps tightly; or, if composite samples are to be collected, place a sample from another sampling interval or location into the homogenization container and mix thoroughly. When compositing is complete, place the sample into appropriate, labeled containers and secure the caps tightly.

7.2.2 Sampling at Depth with Augers and Thin Wall Tube Samplers

This system consists of an auger, or a thin-wall tube sampler, a series of extensions, and a "T" handle (Figure 1, Appendix A). The auger is used to bore a hole to a desired sampling depth, and is then withdrawn. The sample may be collected directly from the auger. If a core sample is to be collected, the auger tip is then replaced with a thin wall tube sampler. The system is then lowered down the borehole, and driven into the soil to the completion depth. The system is withdrawn and the core is collected from the thin wall tube sampler.

Several types of augers are available; these include: bucket type, continuous flight (screw), and post-hole augers. Bucket type augers are better for direct sample recovery because they provide a large volume of sample in a short time. When continuous flight augers are used, the sample can be collected directly from the flights. The continuous flight augers are satisfactory when a composite of the complete soil column is desired. Post-hole augers have limited utility for sample collection as they are designed to cut through fibrous, rooted, swampy soil and cannot be used below a depth of approximately three feet.

The following procedure is used for collecting soil samples with the auger:

1. Attach the auger bit to a drill rod extension, and attach the "T" handle to the drill rod.



U. S. EPA ENVIRONMENTAL RESPONSE TEAM

STANDARD OPERATING PROCEDURES

SOP: 2012
PAGE: 6 of 13
REV: 0.0
DATE: 02/18/00

SOIL SAMPLING

2. Clear the area to be sampled of any surface debris (e.g., twigs, rocks, litter). It may be advisable to remove the first three to six inches of surface soil for an area approximately six inches in radius around the drilling location.
3. Begin augering, periodically removing and depositing accumulated soils onto a plastic sheet spread near the hole. This prevents accidental brushing of loose material back down the borehole when removing the auger or adding drill rods. It also facilitates refilling the hole, and avoids possible contamination of the surrounding area.
4. After reaching the desired depth, slowly and carefully remove the auger from the hole. When sampling directly from the auger, collect the sample after the auger is removed from the hole and proceed to Step 10.
5. Remove auger tip from the extension rods and replace with a pre-cleaned thin wall tube sampler. Install the proper cutting tip.
6. Carefully lower the tube sampler down the borehole. Gradually force the tube sampler into the soil. Do not scrape the borehole sides. Avoid hammering the rods as the vibrations may cause the boring walls to collapse.
7. Remove the tube sampler, and unscrew the drill rods.
8. Remove the cutting tip and the core from the device.
9. Discard the top of the core (approximately 1 inch), as this possibly represents material collected before penetration of the layer of concern. Place the remaining core into the appropriate labeled sample container. Sample homogenization is not required.
10. If volatile organic analysis is to be performed, transfer the sample into an appropriate, labeled sample container with a stainless steel lab spoon, or equivalent and secure the cap tightly. Place the remainder of the sample into a stainless steel, plastic, or other appropriate homogenization container, and mix thoroughly to obtain a homogenous sample representative of the entire sampling interval. Then, either place the sample into appropriate, labeled containers and secure the caps tightly; or, if composite samples are to be collected, place a sample from another sampling interval into the homogenization container and mix thoroughly.

When compositing is complete, place the sample into appropriate, labeled containers and secure the caps tightly.



U. S. EPA ENVIRONMENTAL RESPONSE TEAM

STANDARD OPERATING PROCEDURES

SOP: 2012
PAGE: 7 of 13
REV: 0.0
DATE: 02/18/00

SOIL SAMPLING

11. If another sample is to be collected in the same hole, but at a greater depth, reattach the auger bit to the drill and assembly, and follow steps 3 through 11, making sure to decontaminate the auger and tube sampler between samples.
12. Abandon the hole according to applicable state regulations. Generally, shallow holes can simply be backfilled with the removed soil material.

7.2.3 Sampling with a Trier

The system consists of a trier, and a "T" handle. The auger is driven into the soil to be sampled and used to extract a core sample from the appropriate depth.

The following procedure is used to collect soil samples with a sampling trier:

1. Insert the trier (Figure 2, Appendix A) into the material to be sampled at a 0° to 45° angle from horizontal. This orientation minimizes the spillage of sample.
2. Rotate the trier once or twice to cut a core of material.
3. Slowly withdraw the trier, making sure that the slot is facing upward.
4. If volatile organic analyses are required, transfer the sample into an appropriate, labeled sample container with a stainless steel lab spoon, or equivalent and secure the cap tightly. Place the remainder of the sample into a stainless steel, plastic, or other appropriate homogenization container, and mix thoroughly to obtain a homogenous sample representative of the entire sampling interval. Then, either place the sample into appropriate, labeled containers and secure the caps tightly; or, if composite samples are to be collected, place a sample from another sampling interval into the homogenization container and mix thoroughly. When compositing is complete, place the sample into appropriate, labeled containers and secure the caps tightly.

7.2.4 Sampling at Depth with a Split Spoon (Barrel) Sampler

Split spoon sampling is generally used to collect undisturbed soil cores of 18 or 24 inches in length. A series of consecutive cores may be extracted with a split spoon sampler to give a complete soil column profile, or an auger may be used to drill down to the desired depth for sampling. The split spoon is then driven to its sampling depth through the bottom of the augured hole and the core extracted.

When split spoon sampling is performed to gain geologic information, all work should



U. S. EPA ENVIRONMENTAL RESPONSE TEAM

STANDARD OPERATING PROCEDURES

SOP: 2012
PAGE: 8 of 13
REV: 0.0
DATE: 02/18/00

SOIL SAMPLING

be performed in accordance with ASTM D1586-98, "Standard Test Method for Penetration Test and Split-Barrel Sampling of Soils".

The following procedures are used for collecting soil samples with a split spoon:

1. Assemble the sampler by aligning both sides of barrel and then screwing the drive shoe on the bottom and the head piece on top.
2. Place the sampler in a perpendicular position on the sample material.
3. Using a well ring, drive the tube. Do not drive past the bottom of the head piece or compression of the sample will result.
4. Record in the site logbook or on field data sheets the length of the tube used to penetrate the material being sampled, and the number of blows required to obtain this depth.
5. Withdraw the sampler, and open by unscrewing the bit and head and splitting the barrel. The amount of recovery and soil type should be recorded on the boring log. If a split sample is desired, a cleaned, stainless steel knife should be used to divide the tube contents in half, longitudinally. This sampler is typically available in 2 and 3 1/2 inch diameters. A larger barrel may be necessary to obtain the required sample volume.
6. Without disturbing the core, transfer it to appropriate labeled sample container(s) and seal tightly.

7.2.5 Test Pit/Trench Excavation

A backhoe can be used to remove sections of soil, when detailed examination of soil characteristics are required. This is probably the most expensive sampling method because of the relatively high cost of backhoe operation.

The following procedures are used for collecting soil samples from test pits or trenches:

1. Prior to any excavation with a backhoe, it is important to ensure that all sampling locations are clear of overhead and buried utilities.
2. Review the site specific Health & Safety plan and ensure that all safety precautions including appropriate monitoring equipment are installed as required.



U. S. EPA ENVIRONMENTAL RESPONSE TEAM

STANDARD OPERATING PROCEDURES

SOP: 2012
PAGE: 9 of 13
REV: 0.0
DATE: 02/18/00

SOIL SAMPLING

3. Using the backhoe, excavate a trench approximately three feet wide and approximately one foot deep below the cleared sampling location. Place excavated soils on plastic sheets. Trenches greater than five feet deep must be sloped or protected by a shoring system, as required by OSHA regulations.
4. A shovel is used to remove a one to two inch layer of soil from the vertical face of the pit where sampling is to be done.
5. Samples are taken using a trowel, scoop, or coring device at the desired intervals. Be sure to scrape the vertical face at the point of sampling to remove any soil that may have fallen from above, and to expose fresh soil for sampling. In many instances, samples can be collected directly from the backhoe bucket.
6. If volatile organic analyses are required, transfer the sample into an appropriate, labeled sample container with a stainless steel lab spoon, or equivalent and secure the cap tightly. Place the remainder of the sample into a stainless steel, plastic, or other appropriate homogenization container, and mix thoroughly to obtain a homogenous sample representative of the entire sampling interval. Then, either place the sample into appropriate, labeled containers and secure the caps tightly; or, if composite samples are to be collected, place a sample from another sampling interval into the homogenization container and mix thoroughly. When compositing is complete, place the sample into appropriate, labeled containers and secure the caps tightly.
7. Abandon the pit or excavation according to applicable state regulations. Generally, shallow excavations can simply be backfilled with the removed soil material.

8.0 CALCULATIONS

This section is not applicable to this SOP.

9.0 QUALITY ASSURANCE/QUALITY CONTROL

There are no specific quality assurance (QA) activities which apply to the implementation of these procedures. However, the following QA procedures apply:

1. All data must be documented on field data sheets or within site logbooks.
2. All instrumentation must be operated in accordance with operating instructions as supplied by the manufacturer, unless otherwise specified in the work plan. Equipment checkout and calibration



U. S. EPA ENVIRONMENTAL RESPONSE TEAM

STANDARD OPERATING PROCEDURES

SOP: 2012
PAGE: 10 of 13
REV: 0.0
DATE: 02/18/00

SOIL SAMPLING

activities must occur prior to sampling/operation, and they must be documented.

10.0 DATA VALIDATION

This section is not applicable to this SOP.

11.0 HEALTH AND SAFETY

When working with potentially hazardous materials, follow U.S. EPA, OSHA and corporate health and safety procedures, in addition to the procedures specified in the site specific Health & Safety Plan..

12.0 REFERENCES

Mason, B.J. 1983. Preparation of Soil Sampling Protocol: Technique and Strategies. EPA-600/4-83-020.

Barth, D.S. and B.J. Mason. 1984. Soil Sampling Quality Assurance User's Guide. EPA-600/4-84-043.

U.S. Environmental Protection Agency. 1984 Characterization of Hazardous Waste Sites - A Methods Manual: Volume II. Available Sampling Methods, Second Edition. EPA-600/4-84-076.

de Vera, E.R., B.P. Simmons, R.D. Stephen, and D.L. Storm. 1980. Samplers and Sampling Procedures for Hazardous Waste Streams. EPA-600/2-80-018.

ASTM D 1586-98, ASTM Committee on Standards, Philadelphia, PA.



U. S. EPA ENVIRONMENTAL RESPONSE TEAM

STANDARD OPERATING PROCEDURES

SOP: 2012
PAGE: 11 of 13
REV: 0.0
DATE: 02/18/00

SOIL SAMPLING

APPENDIX A
Figures
SOP #2012
February 2000



U. S. EPA ENVIRONMENTAL RESPONSE TEAM

STANDARD OPERATING PROCEDURES

SOP: 2012
PAGE: 12 of 13
REV: 0.0
DATE: 02/18/00

SOIL SAMPLING

FIGURE 1. Sampling Augers

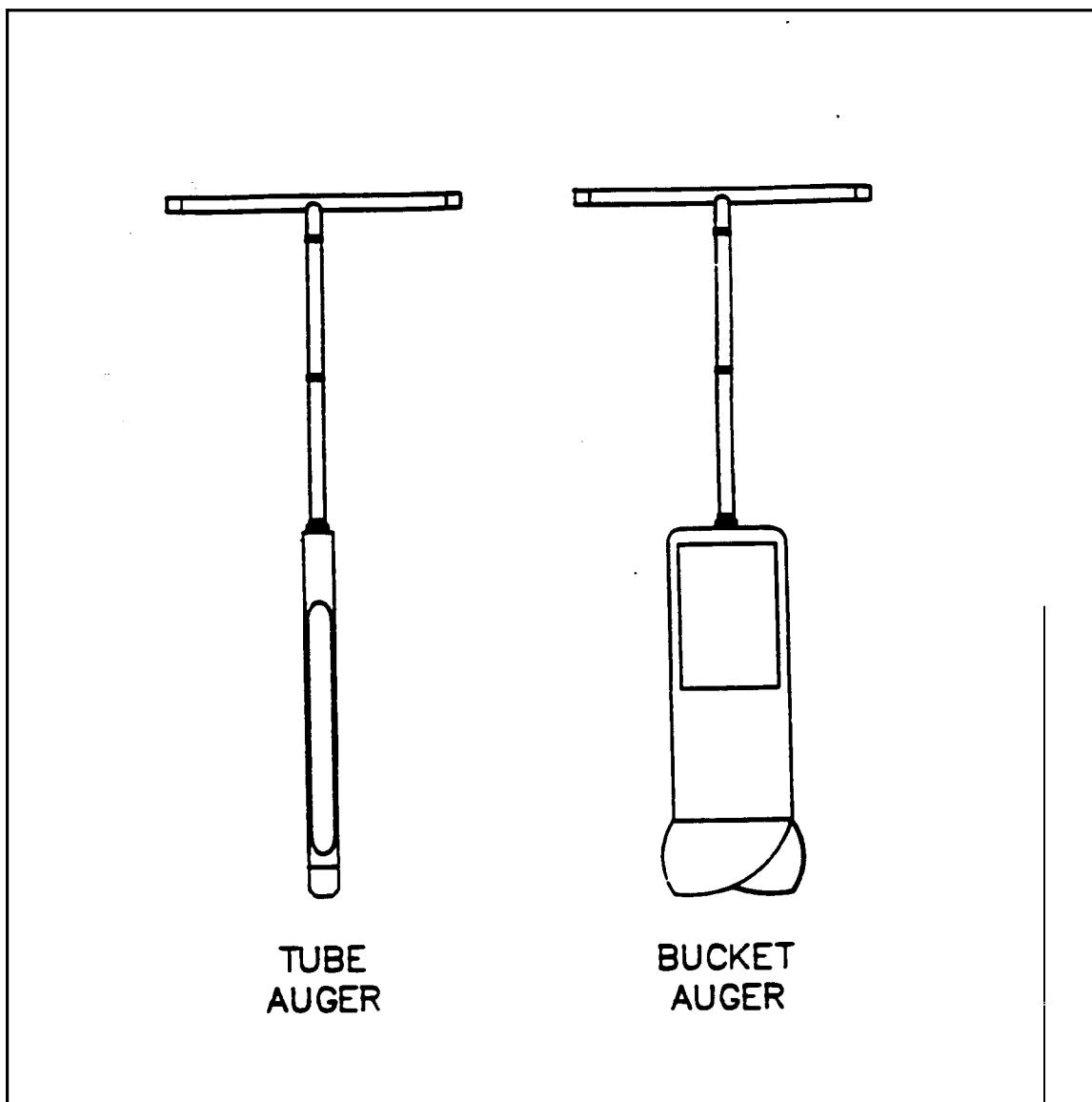



U. S. EPA ENVIRONMENTAL RESPONSE TEAM

STANDARD OPERATING PROCEDURES

SOP: 2012
PAGE: 13 of 13
REV: 0.0
DATE: 02/18/00

SOIL SAMPLING

FIGURE 2. Sampling Trier

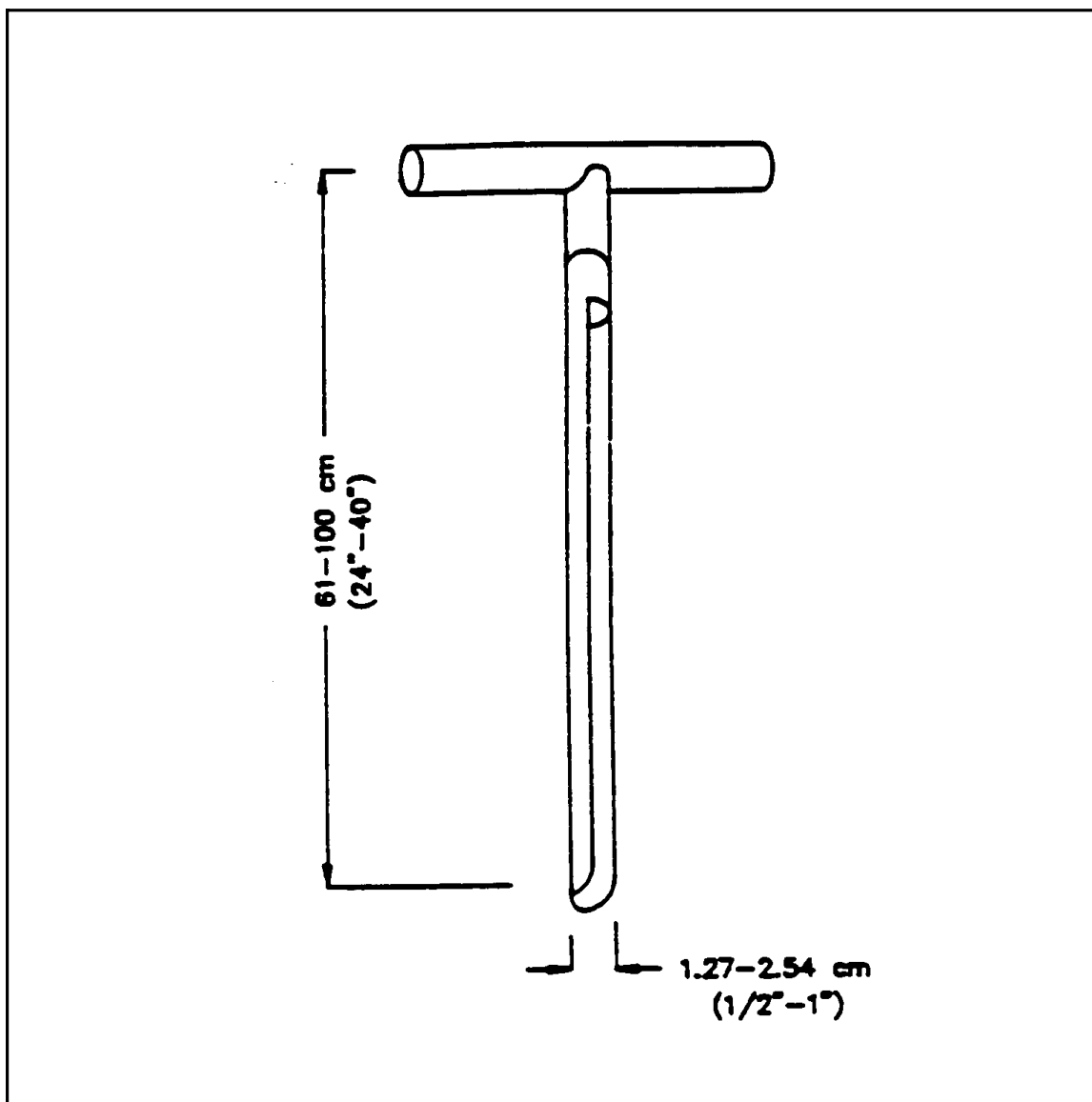



Title:	SOIL SAMPLING
Category:	ENV 3.13
Revised:	August 1997

STANDARD OPERATING PROCEDURE

SOIL SAMPLING

© 1997 Ecology and Environment, Inc.

ecology and environment, inc.

368 Pleasant View Drive / Lancaster, New York 14086 / (716) 684-8060



TITLE: SOIL SAMPLING

CATEGORY: ENV 3.13

REVISED: August 1997

None of the information contained in this Ecology and Environment, Inc., (E & E) publication is to be construed as granting any right, by implication or otherwise, for the manufacture, sale, or use in connection with any method, apparatus, or product covered by letters patent, nor as ensuring anyone against liability for infringement of letters patent.

Anyone wishing to use this E & E publication should first seek permission from the company. Every effort has been made by E & E to ensure the accuracy and reliability of the information contained in the document; however, the company makes no representations, warranty, or guarantee in connection with this E & E publication and hereby expressly disclaims any liability or responsibility for loss or damage resulting from its use; for any violation of any federal, state, or municipal regulation with which this E & E publication may conflict; or for the infringement of any patent resulting from the use of the E & E publication.



TITLE:	SOIL SAMPLING	
CATEGORY:	ENV 3.13	REVISED: August 1997

TABLE OF CONTENTS

<u>Section</u>	<u>Page</u>
1. Introduction	1
2. Scope	1
3. Method Summary	1
4. Sample Preservation, Containers, Handling, and Storage.....	1
5. Potential Problems.....	2
6. Soil Sampling Equipment	3
6.1 Geophysical Equipment	5
7. Reagents	5
8. Procedures	5
8.1 Office Preparation	5
8.2 Field Preparation	6
8.3 Representative Sample Collection	6
8.3.1 Sampling Approaches.....	6
8.3.2 Surface Soil Samples	10
8.3.3 Sampling at Depth with Augers and Thin-Walled Tube Samplers	11
8.3.4 Sampling at Depth with a Trier	13
8.3.5 Sampling at Depth with a Split-Spoon (Barrel) Sampler	14
8.3.6 Test Pit/Trench Excavation.....	15
8.4 Sample Preparation	16
8.4.1 Sample Quantity and Volume.....	16
8.4.2 Sample Preservation and Holding Time	16
8.4.3 Removing Extraneous Material	16
8.4.4 Homogenizing Samples	16
8.4.5 Compositing Samples	20
8.4.6 Splitting Samples	20



TITLE:	SOIL SAMPLING	
CATEGORY:	ENV 3.13	REVISED: August 1997

8.5	Post-Operations	20
8.5.1	Field	20
8.5.2	Office	20
9.	Calculations	20
10.	Quality Assurance/Quality Control	20
10.1	Sampling Documentation	21
10.1.1	Soil Sample Label	21
10.1.2	Logbook	22
10.1.3	Chain of Custody	22
10.2	Sampling Design	22
11.	Data Validation	22
11.1	Quality Assurance/Quality Control Samples	23
11.1.1	Field Duplicates (Replicates)	23
11.1.2	Collocated Samples	23
11.1.3	Background Samples	23
11.1.4	Rinsate (Equipment) Blanks	23
11.1.5	Performance Evaluation Samples	23
11.1.6	Matrix Spike/Matrix Spike Duplicates (MS/MSDs)	23
11.1.7	Field Blanks	23
11.1.8	Trip Blanks	24
12.	Health and Safety	24
12.1	Hazards Associated with On-Site Contaminants	24
13.	References	24
 <u>Appendix</u>		
A	Sampling Augers	26
B	Sampling Trier	27
C	Split-Spoon Sampler	28



TITLE:	SOIL SAMPLING	
CATEGORY:	ENV 3.13	REVISED: August 1997

LIST OF TABLES

<u>Table</u>		<u>Page</u>
5-1	Soil Sampling Equipment	2
8-1	Representative Sampling Approach Comparison	7
8-2	Standard Sampling Holding Times, Preservation Methods, and Volume Requirements.....	17



TITLE:	SOIL SAMPLING	
CATEGORY:	ENV 3.13	REVISED: August 1997

LIST OF FIGURES

<u>Figure</u>		<u>Page</u>
8-1	Random Sampling.....	8
8-2	Stratified Random Sampling.....	8
8-3	Systematic Grid Sampling.....	8
8-4	Systematic Random Sampling	9
8-5	Search Sampling.....	10
8-6	Transect Sampling.....	10
8-7	Quartering to Homogenized and Split Samples.....	21



TITLE:	SOIL SAMPLING		
CATEGORY:	ENV 3.13	REVISED:	August 1997

1. Introduction

This document describes the procedures for the collection of representative soil samples. Representative sampling ensures the accurate characterization of site conditions. Analysis of soil samples may determine pollutant concentrations and the accompanying risks to public health, welfare, or the environment.

2. Scope

Included in this discussion are procedures for obtaining representative samples, quality assurance/quality control (QA/QC) measures, proper documentation of sampling activities, and recommendations for personnel safety.

3. Method Summary

Soil samples may be recovered using a variety of methods and equipment. These are dependent on the depth of the desired sample, the type of sample required (disturbed vs. undisturbed), and the soil type.

Samples of near-surface soils may be easily obtained using a spade, stainless-steel spoon, trowel, or scoop. Sampling at greater depths may be performed using a hand auger; a power auger; or, if a test pit is required, a backhoe.

All sampling devices should be cleaned using pesticide-grade acetone (assuming that acetone is not a target compound) or methanol, then wrapped in clean aluminum foil, and custody sealed for identification. The sampling equipment should remain in this wrapping until it is needed. Each sampler should be used for one sample only. However, dedicated tools may be impractical if there is a large number of soil samples required. In this case, samplers should be cleaned in the field using standard decontamination procedures as outlined in E & E's Standard Operating Procedure (SOP) for Sampling Equipment Decontamination (see ENV 3.15).

4. Sample Preservation, Containers, Handling, and Storage

The chemical preservation of solids is not generally recommended. Refrigeration is usually the best approach, supplemented by a minimal holding time.

Soil samples should be handled according to the procedures outlined in E & E's SOP for Sample Packaging (see ENV 3.16).



TITLE:	SOIL SAMPLING	
CATEGORY:	ENV 3.13	REVISED: August 1997

5. Potential Problems

Potential problems with soil sampling include cross-contamination of samples and improper sample collection. Cross-contamination problems can be eliminated or minimized through the use of dedicated sampling equipment and bottles. If this is not possible or practical, then decontamination of sampling equipment is necessary. Improper sample collection is generally the result of the use of contaminated equipment; the disturbance of the matrix, resulting in compaction of the sample; and inadequate homogenization of the sample where required, resulting in variable, nonrepresentative results. Specific advantages and disadvantages of soil sampling equipment are presented in Table 5-1.

Table 5-1 Soil Sampling Equipment

Equipment	Applicability	Advantages and Disadvantages
Trier	Soft surface soil	Inexpensive; easy to use and decontaminate; difficult to use in stony, dry, or sandy soil.
Scoop, trowel, spoon, or spatula	Soft surface soil	Inexpensive; easy to use and decontaminate; trowels with painted surfaces should be avoided.
Tulip bulb planter	Soft soil, 0 to 6 inches	Easy to use and decontaminate; uniform diameter and sample volume; preserves soil core (suitable for volatile organic analysis (VOA) and undisturbed sample collection); limited depth capability; not useful for hard soils.
Spade or shovel	Medium soil, 0 to 12 inches	Easy to use and decontaminate; inexpensive; can result in sample mixing and loss of volatile organic compounds (VOCs).
Vehimeyer soil outfit	Soil, 0 to 10 feet	Difficult to drive into dense or hard material; can be difficult to pull from ground.
Soil coring device and auger	Soft soil, 0 to 24 inches	Relatively easy to use; preserves soil core (suitable for VOA and undisturbed sample collection); limited depth capability; can be difficult to decontaminate.
Thin-walled tube sampler	Soft soil, 0 to 10 feet	Easy to use; preserves soil core (suitable for VOA and undisturbed sample collection); may be used to help maintain integrity of VOA samples; easy to decontaminate; can be difficult to remove cores from sampler.
Split-spoon sampler	Soil, 0 inches to bed-rock	Excellent depth range; preserves soil core (suitable for VOA and undisturbed sample collection); acetate sleeve may be used to help maintain integrity of VOA samples; useful for hard soils; often used in conjunction with drill rig for obtaining deep cores.



TITLE:	SOIL SAMPLING	
CATEGORY:	ENV 3.13	REVISED: August 1997

Table 5-1 Soil Sampling Equipment

Equipment	Applicability	Advantages and Disadvantages
Shelby tube sampler	Soft soil, 0 inches to bedrock	Excellent depth range; preserves soil core (suitable for VOA and undisturbed sample collection); tube may be used to ship sample to lab undisturbed; may be used in conjunction with drill rig for obtaining deep cores and for permeability testing; not durable in rocky soils.
Laskey sampler	Soil, 0 inches to bedrock	Excellent depth range; preserves soil cores; used in conjunction with drill rig for obtaining deep core; can be difficult to decontaminate.
Bucket auger	Soft soil, 3 inches to 10 feet	Easy to use; good depth range; uniform diameter and sample volume; acetate sleeve may be used to help maintain integrity of VOA samples; may disrupt and mix soil horizons greater than 6 inches in thickness.
Hand-operated power auger	Soil, 6 inches to 15 feet	Good depth range; generally used in conjunction with bucket auger for sample collection; destroys soil core (unsuitable for VOA and undisturbed sample collection); requires two or more equipment operators; can be difficult to decontaminate; requires gasoline-powered engine (potential for cross-contamination).
Continuous-flight auger	Soil, 0 inches to bedrock	Excellent depth range; easy to decontaminate; can be used on all soil samples; results in soil mixing and loss of VOCs.
Dutch auger	Designed specifically for wet, fibrous, or rooted soils (e.g., marshes)	
Eijkelcamp stoney soil auger	Stoney soils and asphalt	
Backhoe	Soil, 0 inches to 10 feet	Good depth range; provides visual indications as to depth of contaminants; allows for recovery of samples at specific depths; can result in loss of VOCs and soil mixing; shoring required at depth.

Note: Samplers may not be suitable for soils with coarse fragments.
 Augers are suitable for soils with limited coarse fragments; only the stoney auger will work well in very gravelly soil.

6. Soil Sampling Equipment

Soil Sampling Equipment List

- Stainless-steel spoon
- Trier
- Scoop
- Trowel



TITLE: SOIL SAMPLING

CATEGORY: ENV 3.13

REVISED: August 1997

- Spatula
- Stainless-steel tulip bulb planter
- Spade or shovel
- Vehimeyer soil sampler outfit
 - tubes
 - points
 - drive head
 - drop hammer
 - fuller jack and grip
- Soil-coring device
- Thin-walled tube sampler
- Split-spoon sampler
- Shelby tube sampler
- Laskey sampler
- Bucket auger
- Hand-operated power auger
- Continuous-flight auger
- Dutch auger
- Eijkelcamp stoney soil auger
- Backhoe
- Hand auger with replaceable sleeves

Sampling Support Equipment and Documentation List

- Sampling plan
- Sample location map
- Safety equipment, as specified in the Health and Safety Plan
- Decontamination supplies and equipment, as described in the Work Plan
- Compass
- Tape measure
- Survey stakes or flags
- Camera
- Stainless-steel buckets or bowls
- Sample containers, precleaned (e.g., I-Chem)
- Logbook
- Chain-of-custody forms
- Plastic sheet
- Soil gas probes
- Infiltrometer
- Pounding sleeve
- Extension rods
- T-handle



TITLE: SOIL SAMPLING

CATEGORY: ENV 3.13

REVISED: August 1997

Labeling, Packaging, and Shipping Supplies

- Coolers
- Labels for sample containers and coolers (e.g., “fragile”)
- Ice
- Plastic bags for sample containers and ice
- ESC paint cans and clamps for polychlorinated biphenyl sampling
- Vermiculite (only if certified asbestos free) or other absorbent
- Duct and strapping tape
- Federal Express airbills and pouches

6.1 Geophysical Equipment

Geophysical techniques can be integrated with field analytical and soil sampling equipment to help define areas of subsurface contamination. For a description of the geophysical techniques and associated applications, refer to E & E’s SOP for Surface Geophysical Techniques (see GEO 4.2).

7. Reagents

This procedure does not require the use of reagents except for decontamination of equipment, as required. Refer to E & E’s SOP for Sampling Equipment Decontamination (see ENV 3.15) and the Site-Specific Work Plan for proper decontamination procedures and appropriate solvents.

8. Procedures

8.1 Office Preparation

1. The preparation of a Health and Safety Plan is required prior to any sampling. The plan must be approved and signed by the Corporate Health and Safety Officer or his/her designee (i.e., the Regional Safety Coordinator).
2. Prepare a Sampling Plan to meet the data quality objectives of the project in accordance with contract requirements. Review available background information (i.e., topographic maps, soil survey maps, geologic maps, other site reports, etc.) to determine the extent of the sampling effort, the sampling method to be employed, and the type and amounts of equipment and supplies required.
3. Obtain necessary sampling and monitoring equipment (see Section 6), decontaminate or preclean the equipment, and ensure that it is in working order.



TITLE: SOIL SAMPLING

CATEGORY: ENV 3.13

REVISED: August 1997

4. Contact the delivery service to confirm the ability to ship all equipment and samples. Determine whether shipping restrictions exist.
5. Prepare schedules and coordinate with staff, clients, and regulatory agencies, if appropriate.

8.2 Field Preparation

1. Identify local suppliers of sampling expendables (e.g., ice and plastic bags) and overnight delivery services (e.g., Federal Express).
2. Decontaminate or preclean all equipment before soil sampling, as described in E & E's SOP for Sampling Equipment Decontamination (see ENV 3.15), or as deemed necessary.
3. A general site survey should be performed prior to site entry in accordance with the Health and Safety Plan, followed by a site safety meeting.
4. Identify and stake all sampling locations. If required, the proposed locations may be adjusted based on site access, property boundaries, and surface obstructions. All staked locations will be utility-cleared by the property owner or field team prior to soil sampling.

8.3 Representative Sample Collection

The objective of representative sampling is to ensure that a sample or group of samples adequately reflects site conditions.

8.3.1 Sampling Approaches

It is important to select an appropriate sampling approach for accurate characterization of site conditions. Each approach is defined below. Table 8-1 summarizes the following sampling approaches and ranks them from most to least suitable based on the sampling objective.

8.3.1.1 Judgmental Sampling

Judgmental sampling is based on the subjective selection of sampling locations relative to historical site information, on-site investigation (site walk-over), etc. There is no randomization associated with this sampling approach because samples are collected primarily at areas of suspected highest contaminant concentrations. Therefore, any statistical calculations based on the sampling results would be unfairly biased.



TITLE:	SOIL SAMPLING		
CATEGORY:	ENV 3.13	REVISED:	August 1997

Table 8-1 Representative Sampling Approach Comparison

Sampling Objective	Judgmental	Random	Stratified Random	Systematic Grid	Systematic Random	Search	Transect
Establish Threat	1	4	3	2 ^a	3	3	2
Identify Sources	1	4	2	2 ^a	3	2	3
Delineate Extent of Contamination	4	3	3	1 ^b	1	1	1
Evaluate Treatment and Disposal Options	3	3	1	2	2	4	2
Confirm Cleanup	4	1 ^c	3	1 ^b	1	1	1 ^c

- 1 Preferred approach.
- 2 Acceptable approach.
- 3 Moderately acceptable approach.
- 4 Least acceptable approach.
- a Should be used with field analytical screening.
- b Preferred only where known trends are present.
- c Allows for statistical support of cleanup verification if sampling over entire site.

8.3.1.2 Random Sampling

Random sampling involves the arbitrary collection of samples within a defined area. Refer to EPA 1984 and EPA 1989 for a random number table and guidelines on selecting sample coordinates. The arbitrary selection of sample locations requires each sample location to be chosen independently so that results in all locations within the area of concern have an equal chance of being selected. To facilitate statistical probabilities of contaminant concentration, the area of concern must be homogeneous with respect to the parameters being monitored. Thus, the higher the degree of heterogeneity, the less the random sampling approach will reflect site conditions (see Figure 8-1).

8.3.1.3 Stratified Random Sampling

Stratified random sampling relies primarily on historical information and prior analytical results to divide the area of concern into smaller sampling areas, or “strata.” Strata can be defined by several factors, including sampling depth, contaminant concentration levels, and contaminant source areas. Sampling locations should be selected within a strata using random selection procedures (see Figure 8-2).

8.3.1.4 Systematic Grid Sampling

Systematic grid sampling involves the division of the area of concern into smaller sampling areas using a square or triangular grid. Samples are then collected from the intersections of the grid lines, or “nodes.” The origin and direction for placement of the grid should be selected by using an initial random point. The distance between nodes is dependent upon the size of the area of concern and the number of samples to be collected (see Figure 8-3).

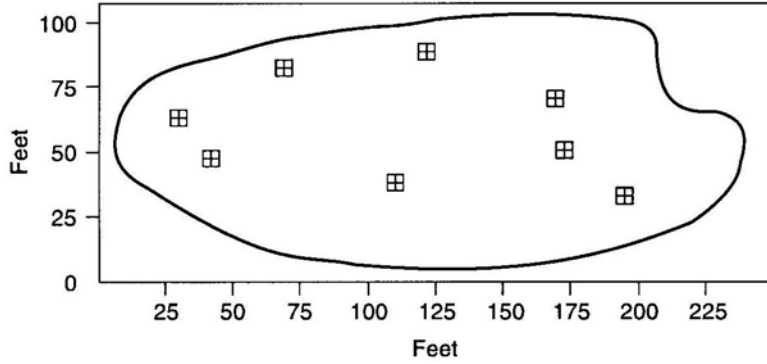

Figure 8-1 Random Sampling**

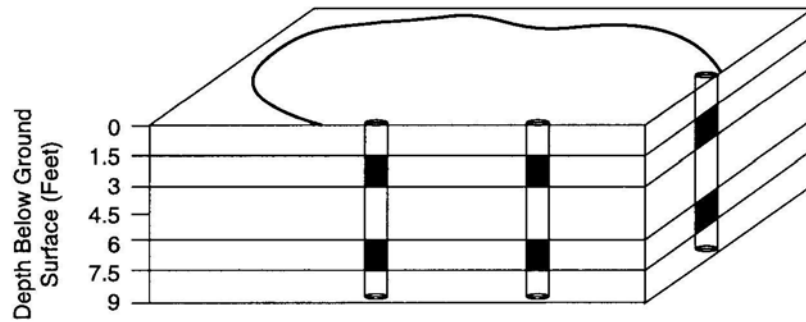

Figure 8-2 Stratified Random Sampling

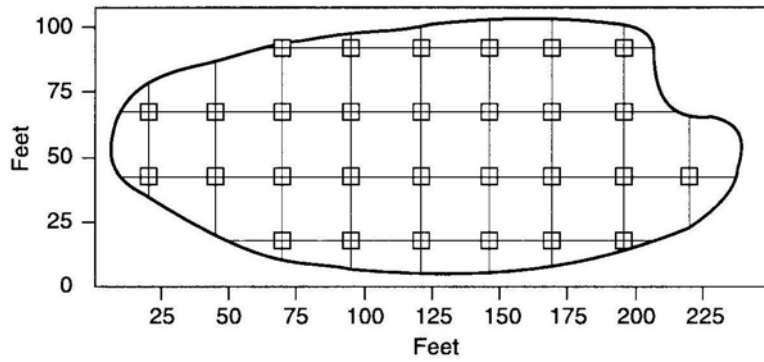

Figure 8-3 Systematic Grid Sampling**

** After EPA, February 1989

Legend	
—	Sample Area Boundary
⊠	Selected Sample Location
■	Sample Location



TITLE:	SOIL SAMPLING	
CATEGORY:	ENV 3.13	REVISED: August 1997

8.3.1.5 Systematic Random Sampling

Systematic random sampling involves dividing the area of concern into smaller sampling areas as described in Section 8.3.1.4. Samples are collected within each grid cell using random selection procedures (see Figure 8-4).

8.3.1.6 Biased-Search Sampling

Search sampling utilizes a systematic grid or systematic random sampling approach to define areas where contaminants exceed cleanup standards (i.e., hot spots). The distance between the grid lines and number of samples to be collected are dependent upon the acceptable level of error (i.e., the chance of missing a hot spot). This sampling approach requires that assumptions be made regarding the size, shape, and depth of hot spots (see Figure 8-5).

8.3.1.7 Transect Sampling

Transect sampling involves establishing one or more transect lines, parallel or nonparallel, across the area of concern. If the lines are parallel, this sampling approach is similar to systematic grid sampling. The advantage of transect sampling over systematic grid sampling is the relative ease of establishing and relocating transect lines as opposed to an entire grid. Samples are collected at regular intervals along the transect line at the surface and/or at a specified depth(s). The distance between the sample locations is determined by the length of the line and the number of samples to be collected (see Figure 8-6).

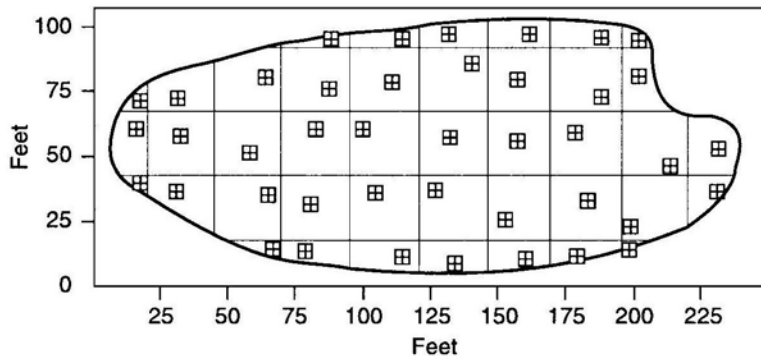

Figure 8-4 Systematic Random Sampling

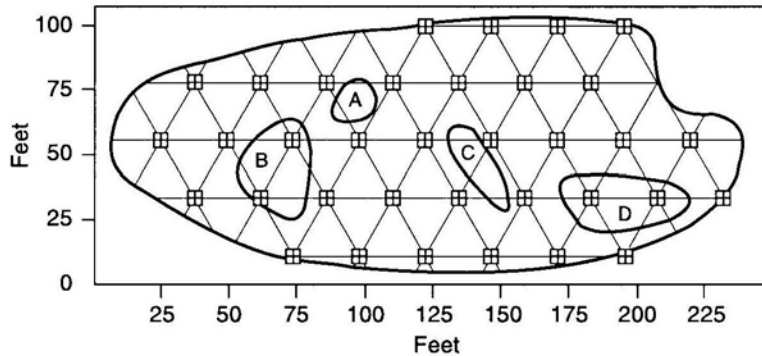

Figure 8-5 Search Sampling

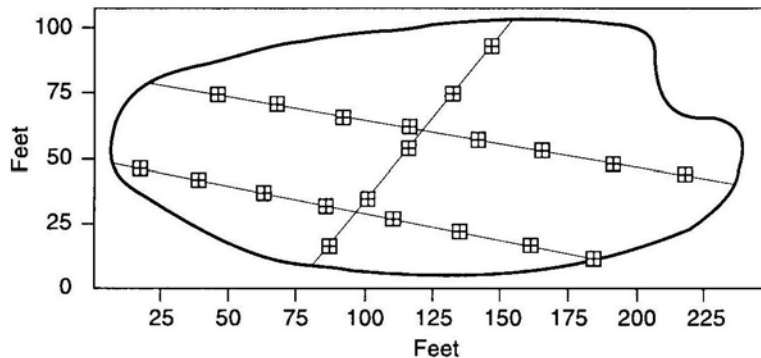
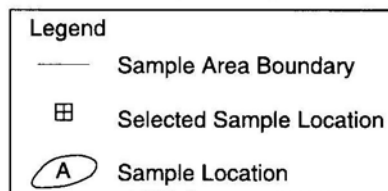

Figure 8-6 Transect Sampling

After EPA, February 1989



8.3.2 Surface Soil Samples

Collection of samples from near-surface soil can be accomplished with tools such as spades, spoons, shovels, and scoops. The surface material can be removed to the required depth with this equipment; stainless-steel or plastic scoops can then be used to collect the sample.

This method can be used in most soil types, but is limited to sampling near-surface areas. Accurate, representative samples can be collected with this procedure, depending on the care and precision demonstrated by the sampling technician. The use of a flat, pointed mason trowel to cut a block of the desired soil can be helpful when undisturbed profiles are required (e.g., for volatile organic analyses [VOAs]). A stainless-steel scoop, lab spoon, or plastic spoon will suf-



TITLE: SOIL SAMPLING

CATEGORY: ENV 3.13

REVISED: August 1997

fice in most other applications. Care should be exercised to avoid the use of devices plated with chrome or other materials, as is common with garden implements such as potting trowels.

Soil samples are collected using the following procedure:

1. Carefully remove the top layer of soil to the desired sample depth with a precleaned spade;
2. Using a precleaned, stainless-steel scoop, spoon, trowel, or plastic spoon, remove and discard the thin layer of soil from the area that came into contact with the shovel;
3. Transfer the sample into an appropriate container using a stainless-steel or plastic lab spoon or equivalent. If composite samples are to be collected, place the soil sample in a stainless-steel or plastic bucket and mix thoroughly to obtain a homogeneous sample representative of the entire sampling interval. Place the soil samples into labeled containers. (**Caution: Never composite VOA samples**);
4. VOA samples should be collected directly from the bottom of the hole before mixing the sample to minimize volatilization of contaminants;
5. Check to ensure that the VOA vial Teflon liner is present in the cap, if required. Fill the VOA vial fully to the top to reduce headspace. Secure the cap tightly. The chemical preservation of solids is generally not recommended. Refrigeration is usually the best approach, supplemented by a minimal holding time;
6. Ensure that a sufficient sample size has been collected for the desired analysis, as specified in the Sampling Plan;
7. Decontaminate equipment between samples according to E & E's SOP for Sampling Equipment Decontamination (see ENV 3.15); and
8. Fill in the hole and replace grass turf, if necessary.

QA/QC samples should be collected as specified, according to the Work Plan.

8.3.3 Sampling at Depth with Augers and Thin-Walled Tube Samplers

This system consists of an auger, a series of extensions, a T-handle, and a thin-walled tube. The auger is used to bore a hole to a desired sampling depth and is then withdrawn. The auger tip is then replaced with a tube core sampler, lowered down the borehole, and driven into the soil to the completion depth. The core is then withdrawn and the sample is collected.

Several augers are available, including bucket type, continuous-flight (screw), and post-hole augers. Because they provide a large volume of sample in a short time, bucket types are better for direct sample recovery. When continuous-flight augers are used, the sample can be collected directly off the flights, usually at 5-foot intervals. The continuous-flight augers are sat-



TITLE: SOIL SAMPLING

CATEGORY: ENV 3.13

REVISED: August 1997

isfactory for use when a composite of the complete soil column is desired. Posthole augers have limited utility for sample collection because they are designed to cut through fibrous, rooted, swampy soil.

The following procedures will be used for collecting soil samples with the hand auger:

1. Attach the auger bit to a drill rod extension, and attach the T-handle to the drill rod.
2. Clear the area to be sampled of any surface debris (e.g., twigs, rocks, and litter). It may be advisable to remove the first 3 to 6 inches of surface soil from an area approximately 6 inches in radius around the drilling location.
3. Begin augering, periodically removing and depositing accumulated soils onto a canvas or plastic sheet spread near the hole. This prevents accidental brushing of loose material back down the borehole when removing the auger or adding drill rods. It also facilitates refilling the hole and avoids possible contamination of the surrounding area.
4. After reaching the desired depth, slowly and carefully remove the auger from the boring. When sampling directly from the auger, collect the sample after the auger is removed from the boring and proceed to Step 11.
5. A precleaned stainless-steel auger sleeve can also be used to collect a sample. After reaching the desired sampling depth, remove the auger and place the sleeve inside the auger. Collect the sample with the auger. Remove the auger from the boring. The sample will be collected only from the sleeve. The soil from the auger tip should never be used for the sample.
6. Remove the auger tip from the drill rods and replace with a precleaned thin-walled tube sampler. Install the proper cutting tip.
7. Carefully lower the tube sampler down the borehole. Gradually force the tube sampler into the soil. Care should be taken to avoid scraping the borehole sides. Avoid hammering the drill rods to facilitate coring, because the vibrations may cause the boring walls to collapse.
8. Remove the tube sampler and unscrew the drill rods.
9. Remove the cutting tip and core from the device.
10. Discard the top of the core (approximately 1 inch), because this represents material collected before penetration of the layer in question. Place the remaining core into the sample container.



TITLE: SOIL SAMPLING

CATEGORY: ENV 3.13

REVISED: August 1997

11. If required, ensure that a Teflon liner is present in the cap. Secure the cap tightly onto the sample container. Place the sample bottle in a plastic bag and put on ice to keep the sample at 4°Celsius.
12. Carefully and clearly label the container with the appropriate sample tag, addressing all the categories or parameters listed in E & E's SOP for Sample Packaging and Shipping (see ENV 3.16).
13. Use the chain-of-custody form to document the types and numbers of soil samples collected and logged. Verify that the chain-of-custody form is correctly and completely filled out.
14. Record the time and date of sample collection, as well as a description of the sample, in the field logbook.
15. If another sample is to be collected in the sample hole, but at a greater depth, re-attach the auger bit to the drill and assembly, and follow Steps 3 through 11, making sure to decontaminate the auger and tube sampler between samples.
16. Abandon the hole according to applicable regulations. Generally, shallow holes can simply be backfilled with the removed soil material.
17. Decontaminate the sampling equipment per E & E's SOP for Sampling Equipment Decontamination (see ENV 3.15).

8.3.4 Sampling at Depth with a Trier

1. Insert the trier into the material to be sampled at a 0° to 45° angle from horizontal. This orientation minimizes the spillage of sample material. Extraction of samples may require tilting of the containers.
2. Rotate the trier once or twice to cut a core of material.
3. Slowly withdraw the trier, making sure that the slot is facing upward.
4. Transfer the sample into a suitable container with the aid of a spatula and brush.
5. If required, ensure that a Teflon liner is present in the cap. Secure the cap tightly onto the sample container. Samples are handled in accordance with E & E's SOP for Sample Packaging and Shipping (see ENV 3.16).
6. Carefully and clearly label the container with the appropriate sample tag, addressing all the categories or parameters listed in E & E's SOP for Sample Packaging and Shipping (see ENV 3.16).



TITLE: SOIL SAMPLING

CATEGORY: ENV 3.13

REVISED: August 1997

7. Use the chain-of-custody form to document the types and numbers of soil samples collected and logged.
8. Record the time and date of sample collection as well as a description of the sample and any associated air monitoring measurements in the field logbook.
9. Abandon the hole according to applicable regulations. Generally, shallow holes can simply be backfilled with the removed soil material.
10. Decontaminate sampling equipment per E & E's SOP for Sampling Equipment Decontamination (see ENV 3.15).

8.3.5 Sampling at Depth with a Split-Spoon (Barrel) Sampler

The procedure for split-spoon sampling describes the extraction of undisturbed soil cores of 18 or 24 inches in length. A series of consecutive cores may be sampled to give a complete soil column, or an auger may be used to drill down to the desired depth for sampling. The split spoon is then driven to its sampling depth through the bottom of the augured hole and the core extraction.

This sampling device may be used to collect information such as soil density. All work should be performed in accordance with American Society for Testing and Materials (ASTM) D 1586-84, *Penetration Test and Split Barrel Sampling of Soils*.

1. Assemble the sampler by aligning both sides of the barrel and then screwing the bit on the bottom and the heavier head piece on top. Install a retaining cap in the head piece if necessary.
2. Place the sampler in a perpendicular position on the sample material.
3. Using a sledge hammer or well ring, if available, drive the tube. Do not drive past the bottom of the head piece because compression of the sample will result.
4. Record the length of the tube used to penetrate the material being sampled and the number of blows required to obtain this depth.
5. Withdraw the split spoon and open by unscrewing the bit and head. If a split sample is desired, a clean stainless-steel knife should be used to divide the tube contents in half, lengthwise. This sampler is available in 2- and 3.5-inch diameters. The required sample volume may dictate the use of the larger barrel. If needed, stainless-steel or Teflon sleeves can be used inside the split-spoon. If sleeves removed from the split-spoon are capped immediately, volatilization of contaminants can be reduced. When split-spoon sampling is performed to gain geologic information, all work should be performed in accordance with ASTM D 1586-67 (reapproved in 1974).



TITLE: SOIL SAMPLING

CATEGORY: ENV 3.13

REVISED: August 1997

6. Cap the sample container, place in a double plastic bag, and attach the label and custody seal. Record all pertinent data in the field logbook and complete the sample analysis request form and chain-of-custody record before collecting the next sample.
7. If required, preserve or place the sample on ice.
8. Follow proper decontamination procedures and deliver samples to the laboratory for analysis.

8.3.6 Test Pit/Trench Excavation

These relatively large excavations are used to remove sections of soils when detailed examination of soil characteristics (horizontal, structure, color, etc.) is required. It is the least cost-effective sampling method because of the relatively high cost of backhoe operation.

1. Prior to any excavations with a backhoe, it is important to ensure that all sampling locations are clear of utility lines and poles (subsurface as well as above surface).
2. Using the backhoe, a trench is dug to approximately 3 feet in width and approximately 1 foot below the cleared sampling depth. Place removed or excavated soils on canvas or plastic sheets, if necessary. Trenches greater than 4 feet deep must be sloped or protected by a shoring system, as required by Occupational Safety and Health Administration (OSHA) regulations.
3. A shovel is used to remove a 1- to 2-inch layer of soil from the vertical face of the pit where sampling is to be done.
4. Samples are collected using a trowel, scoop, or coring device at the desired intervals. Be sure to scrape the vertical face at the point of sampling to remove any soil that may have fallen from above, and to expose soil for sampling. Samples are removed and placed in an appropriate container.
5. If required, ensure that a Teflon liner is present in the cap. Secure the cap tightly onto the sample container. Samples are handled in accordance with E & E's SOP for Sample Packaging and Shipping (see ENV 3.16).
6. Carefully and clearly label the container with the appropriate sample tag, addressing all the categories or parameters listed in E & E's SOP for Sample Packaging and Shipping (see ENV 3.16).
7. Use the chain-of-custody form to document the types and numbers of soil samples collected and logged.
8. Record the time and date of sample collection as well as a description of the sample and any associated air monitoring measurements in the field logbook.



TITLE: SOIL SAMPLING

CATEGORY: ENV 3.13

REVISED: August 1997

9. Abandon the hole according to applicable state regulations. Generally, excavated holes can simply be backfilled with the removed soil material.
10. Decontaminate sampling equipment, including the backhoe bucket, per E & E's SOP for Sampling Equipment Decontamination (see ENV 3.15).

8.4 Sample Preparation

In addition to sampling equipment, representative sample collection includes sample quantity, volume, preservation, and holding time (see Table 8-2). *Sample preparation* refers to all aspects of sample handling after collection. How a sample is prepared can affect its representativeness. For example, homogenizing can result in a loss of volatiles and is therefore inappropriate when volatile contaminants are the concern.

8.4.1 Sample Quantity and Volume

The volume and number of samples necessary for site characterization will vary according to the budget, project schedule, and sampling approach.

8.4.2 Sample Preservation and Holding Time

Sample preservation and holding times are as discussed in Section 4.

8.4.3 Removing Extraneous Material

Discard materials in a sample that are not relevant for site or sample characterization (e.g., glass, rocks, and leaves), because their presence may introduce an error in analytical procedures.

8.4.4 Homogenizing Samples

Homogenizing is the mixing of a sample to provide a uniform distribution of the contaminants. Proper homogenization ensures that the containerized samples are representative of the total soil sample collected. All samples to be composited or split should be homogenized after all aliquots have been combined. Do not homogenize samples for volatile compound analysis.

Table 8-2 Standard Sampling Holding Times, Preservation Methods, and Volume Requirements

Protocol Parameter	Holding Time		Minimum Volume Required		Container Type		Preservation	
	Soil	Water	Soil	Water	Soil	Water	Soil	Water
SW-846								
VOA ^e	14 days from date sampled	14 days from date sampled	15 g	One 40-mL vial; no air space	Two 40-mL vials; no air space	Two 40-mL vials; no air space	Cool to 4°C (ice in cooler)	Add HCl until pH <2 and cool to 4° (ice in cooler)
Semi-VOA (BNAs) ^e	14 days to extract from date sampled	7 days to extract from date sampled	30 g	1 L	8-oz. glass jar with Teflon-lined cap	½-gallon amber glass bottle	Cool to 4°C (ice in cooler)	Cool to 4°C (ice in cooler)
PCBs ^{d,e}	14 days to extract from date sampled	7 days to extract from date sampled	30 g	1 L	4-oz. glass jar with Teflon-lined cap	½-gallon amber glass bottle	Cool to 4°C (ice in cooler)	Cool to 4°C (ice in cooler)
Pesticides/PCBs ^{d,e}	14 days to extract from date sampled	7 days to extract from date sampled	30 g	1 L	8-oz. glass jar with Teflon-lined cap	½-gallon amber glass bottle	Cool to 4°C (ice in cooler)	Cool to 4°C (ice in cooler)
Metals ^c	6 months from date sampled	6 months from date sampled	10 g	300 mL	8-oz. glass jar with Teflon-lined cap	1-L polyethylene bottle with polyethylene-lined cap	Cool to 4°C (ice in cooler)	Add HNO ₃ until pH <2 and cool to 4°C (ice in cooler)
Cyanide ^c	14 days from date sampled	14 days from date sampled	10 g	100 mL	8-oz. glass jar with Teflon-lined cap	1-L polyethylene bottle with polyethylene-lined cap	Cool to 4°C (ice in cooler)	Add NaOH until pH >12 and cool to 4°C (ice in cooler)
Hexavalent chromium ^a	24 hours from time sampled	24 hours from time sampled	10 g	50 mL	8-oz. glass jar with Teflon-lined cap	125-mL polyethylene bottle with polyethylene-lined cap	Cool to 4°C (ice in cooler)	Cool to 4°C (ice in cooler)
Total Organic Carbon (TOC) ^a	NA	28 days from date sampled	5 g	10 mL	8-oz. glass jar with Teflon-lined cap	125-mL polyethylene bottle with polyethylene-lined cap	Cool to 4°C (ice in cooler)	Add H ₂ SO ₄ until pH <2 and cool to 4°C (ice in cooler)
Total Organic Halides (TOX)	NA	7 days from date sampled	100 g	200 mL	8-oz. glass jar with Teflon-lined cap	1-L amber glass bottle	Cool to 4°C (ice in cooler)	Add H ₂ SO ₄ until pH <2 and cool to 4°C (ice in cooler)

CATEGORY:

ENV 3.13

REVISED:

August 1997

TITLE:

SOIL SAMPLING



Table 8-2 Standard Sampling Holding Times, Preservation Methods, and Volume Requirements

Protocol Parameter	Holding Time		Minimum Volume Required		Container Type		Preservation	
	Soil	Water	Soil	Water	Soil	Water	Soil	Water
Total Recoverable Petroleum Hydrocarbons ^e	28 days from date sampled	28 days from date sampled	50 g	1 L	8-oz. glass jar with Teflon-lined cap	1-L amber glass bottle	Cool to 4°C (ice in cooler)	Add H ₂ SO ₄ until pH <2 and cool to 4°C (ice in cooler)
EPA-CLP								
VOA ^e	10 days from date received	10 days from date received	15 g	One 40-mL vial; no air space	Two 40-mL vials; no air space	Two 40-mL vials; no air space	Cool to 4°C (ice in cooler)	Add HCl until pH <2 and cool to 4°C (ice in cooler)
Semi-VOA (BNAs) ^e	10 days to extract from date received	5 days to extract from date received	30 g	1 L	8-oz. glass jar with Teflon-lined cap	½-gallon amber glass bottle	Cool to 4°C (ice in cooler)	Cool to 4°C (ice in cooler)
PCBs ^{d,e}	10 days to extract from date received	5 days to extract from date received	30 g	1 L	4-oz. glass jar with Teflon-lined cap	½-gallon amber glass bottle	Cool to 4°C (ice in cooler)	Cool to 4°C (ice in cooler)
Pesticides/PCBs ^{d,e}	10 days to extract from date received	5 days to extract from date received	30 g	1 L	8-oz. glass jar with Teflon-lined cap	½-gallon amber glass bottle	Cool to 4°C (ice in cooler)	Cool to 4°C (ice in cooler)
Metals ^c	6 months from date sampled	6 months from date sampled	10 g	300 mL	8-oz. glass jar with Teflon-lined cap	1-L polyethylene bottle with polyethylene-lined cap	Cool to 4°C (ice in cooler)	Add HNO ₃ to pH <2 and cool to 4°C (ice in cooler)
Cyanide ^c	12 days from date received	12 days from date received	10 g	100 mL	8-oz. glass jar with Teflon-lined cap	1-L polyethylene bottle with polyethylene-lined cap	Cool to 4°C (ice in cooler)	Add NaOH to pH >12 and cool to 4°C (ice in cooler)
NYSDEC-CLP								
VOA ^e	7 days from date received	10 days from date received	15 g	One 40-mL vial; no air space	Two 40-mL vials; no air space	Two 40-mL vials; no air space	Cool to 4°C (ice in cooler)	Add HCl until pH <2 and cool to 4°C (ice in cooler)
Semi-VOA (BNAs) ^e	5 days to extract from date received	5 days to extract from date received	30 g	1 L	8-oz. glass jar with Teflon-lined cap	½-gallon amber glass bottle	Cool to 4°C (ice in cooler)	Cool to 4°C (ice in cooler)



Table 8-2 Standard Sampling Holding Times, Preservation Methods, and Volume Requirements

Protocol Parameter	Holding Time		Minimum Volume Required		Container Type		Preservation	
	Soil	Water	Soil	Water	Soil	Water	Soil	Water
PCBs ^{d,e}	5 days to extract from date received	5 days to extract from date received	30 g	1 L	4-oz. glass jar with Teflon-lined cap	½-gallon amber glass bottle	Cool to 4°C (ice in cooler)	Cool to 4°C (ice in cooler)
Pesticides/PCBs ^{d,e}	5 days to extract from date received	5 days to extract from date received	30 g	1 L	8-oz. glass jar with Teflon-lined cap	½-gallon amber glass bottle	Cool to 4°C (ice in cooler)	Cool to 4°C (ice in cooler)
Metals ^c	6 months from date sampled	6 months from date sampled	10 g	300 mL	8-oz. glass jar with Teflon-lined cap	1-L polyethylene bottle with polyethylene-lined cap	Cool to 4°C (ice in cooler)	Add HNO ₃ to pH <2 and cool to 4°C (ice in cooler)
Cyanide ^c	12 days from date received	12 days from date received	10 g	100 mL	8-oz. glass jar with Teflon-lined cap	1-L polyethylene bottle with polyethylene-lined cap	Cool to 4°C (ice in cooler)	Add NaOH to pH >12 and cool to 4°C (ice in cooler)
EPA Water and Waste								
Total Dissolved Solids (TDS)	NA	7 days from date sampled	NA	200 mL	NA	1-L polyethylene bottle with polyethylene-lined cap	NA	Cool to 4°C (ice in cooler)

Note: All sample bottles will be prepared in accordance with EPA bottle-washing procedures. These procedures are incorporated in E & E's Laboratory and Field Personnel Chain-of-Custody Documentation and Quality Assurance/Quality Control Procedures Manual, July 1987.

- ^a Technical requirements for sample holding times have been established for water matrices only. However, they are also suggested for use as guidelines in evaluating soil data.
- ^b Holding time for GC/MS analysis is 7 days if samples are not preserved.
- ^c Maximum holding time for mercury is 28 days from time sampled.
- ^d If one container has already been collected for PCB analysis, then only one additional container need be collected for extractable organic, BNA, or pesticides/PCB analysis.
- ^e Extra containers required for MS/MSD.

Key:

NA = Not applicable.



TITLE: SOIL SAMPLING

CATEGORY: ENV 3.13

REVISED: August 1997

8.4.5 Compositing Samples

Compositing is the process of physically combining and homogenizing several individual soil aliquots of the same volume or weight. Compositing samples provides an average concentration of contaminants over a certain number of sampling points. Compositing dilutes high-concentration aliquots; therefore, detection limits should be reduced accordingly. If the composite area is heterogeneous in concentration and its composite value is to be compared to a particular action level, then that action level must be divided by the total number of aliquots making up the composite for accurate determination of the detection limit.

8.4.6 Splitting Samples

Splitting samples (after preparation) is performed when multiple portions of the same samples are required to be analyzed separately. Fill the sample containers simultaneously with alternate spoonfuls of the homogenized sample (see Figure 8-7).

8.5 Post-Operations

8.5.1 Field

Decontaminate all equipment according to E & E's SOP for Sampling Equipment Decontamination (see ENV 3.15).

8.5.2 Office

Organize field notes into a report format and transfer logging information to appropriate forms.

9. Calculations

There are no specific calculations required for these procedures.

10. Quality Assurance/Quality Control

The objective of QA/QC is to identify and implement methodologies that limit the introduction of error into sampling and analytical procedures.



TITLE:	SOIL SAMPLING	
CATEGORY:	ENV 3.13	REVISED: August 1997

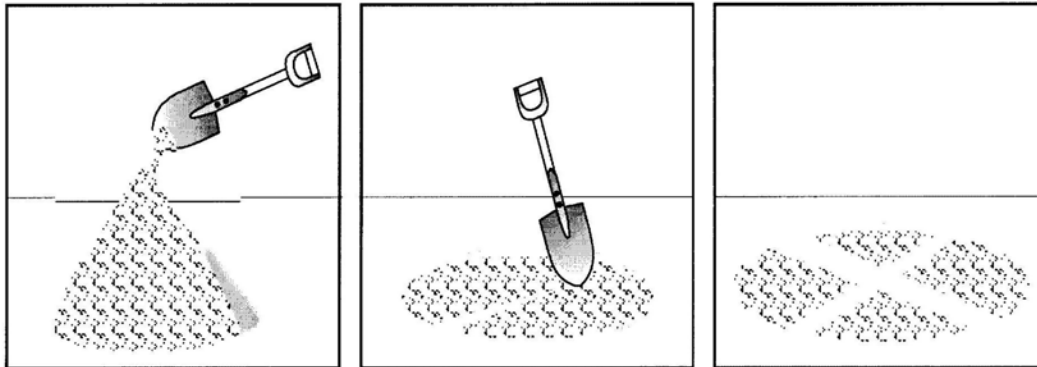

Step 1:

- Cone Sample on hard, clean surface
- Mix by forming new cone

Step 2:

- Quarter after flattening cone

Step 3:

- Divide sample into quarters

Step 4:

- Remix opposite quarters
- Reform cone
- Repeat a minimum of 5 times

After: ASTM Standard C702-87

Figure 8-7 Quartering to Homogenized and Split Samples

10.1 Sampling Documentation

10.1.1 Soil Sample Label

All soil samples shall be documented in accordance with E & E's SOP for Sample Packaging and Shipping (see ENV 3.16). The soil sample label is filled out prior to collecting the sample and should contain the following:

1. Site name or identification.
2. Sample location and identifier.
3. Date samples were collected in a day, month, year format (e.g., 03 Jan 88 for January 3, 1988).
4. Time of sample collection, using 24-hour clock in the hours:minutes format.
5. Sample depth interval. Units used for depths should be in feet and tenths of feet.
6. Preservatives used, if any.
7. Analysis required.



TITLE: SOIL SAMPLING

CATEGORY: ENV 3.13

REVISED: August 1997

8. Sampling personnel.
9. Comments and other relevant observations (e.g., color, odor, sample technique).

10.1.2 Logbook

A bound field notebook will be maintained by field personnel to record daily activities, including sample collection and tracking information. A separate entry will be made for each sample collected. These entries should include information from the sample label and a complete physical description of the soil sample, including texture, color (including notation of soil mottling), consistency, moisture content, cementation, and structure.

10.1.3 Chain of Custody

Use the chain-of-custody form to document the types and numbers of soil samples collected and logged. Refer to E & E's SOP for Sample Packaging and Shipping (see ENV 3.16) for directions on filling out this form.

10.2 Sampling Design

1. Sampling situations vary widely; thus, no universal sampling procedure can be recommended. However, a Sampling Plan should be implemented before any sampling operation is attempted, with attention paid to contaminant type and potential concentration variations.
2. Any of the sampling methods described here should allow a representative soil sample to be obtained, if the Sampling Plan is properly designed.
3. Consideration must also be given to the collection of a sample representative of all horizons present in the soil. Selection of the proper sampler will facilitate this procedure.
4. A stringent QA Project Plan should be outlined before any sampling operation is attempted. This should include, but not be limited to, properly cleaned samplers and sample containers, appropriate sample collection procedures, chain-of-custody procedures, and QA/QC samples.

11. Data Validation

The data generated will be reviewed according to the QA/QC considerations that are identified in Section 10.



TITLE: SOIL SAMPLING

CATEGORY: ENV 3.13

REVISED: August 1997

11.1 Quality Assurance/Quality Control Samples

QA/QC samples are used to identify error due to sampling and/or analytical methodologies and chain-of-custody procedures.

11.1.1 Field Duplicates (Replicates)

Field duplicates are collected from one location and treated as separate samples throughout the sample handling and analytical processes. These samples are used to assess total error for critical samples with contaminant concentrations near the action level.

11.1.2 Collocated Samples

Collocated samples are generally collected 1.5 to 3.0 feet away from selected field samples to determine both local soil and contaminant variations on site. These samples are used to evaluate site variation within the immediate vicinity of sample collection.

11.1.3 Background Samples

Background or “clean” samples are collected from an area upgradient from the contamination area and representative of the typical conditions. These samples provide a standard for comparison of on-site contaminant concentration levels.

11.1.4 Rinsate (Equipment) Blanks

Rinsate blanks are collected by pouring analyte-free water (i.e., laboratory de-ionized water) on decontaminated sampling equipment to test for residual contamination. These samples are used to assess potential cross contamination due to improper decontamination procedures.

11.1.5 Performance Evaluation Samples

Performance evaluation samples are generally prepared by a third party, using a quantity of analyte(s) known to the preparer but unknown to the laboratory. The percentage of analyte(s) identified in the sample is used to evaluate laboratory procedural error.

11.1.6 Matrix Spike/Matrix Spike Duplicates (MS/MSDs)

MS/MSD samples are spiked in the laboratory with a known quantity of analyte(s) to confirm percent recoveries. They are primarily used to check sample matrix interferences.

11.1.7 Field Blanks

Field blanks are prepared in the field with certified clean sand, soil, or water. These samples are used to evaluate contamination error associated with sampling methodology and laboratory procedures.



TITLE: SOIL SAMPLING

CATEGORY: ENV 3.13

REVISED: August 1997

11.1.8 Trip Blanks

Trip blanks are prepared prior to going into the field using certified clean sand, soil, or water. These samples are used to assess error associated with sampling methodology and analytical procedures for volatile organics.

12. Health and Safety

12.1 Hazards Associated with On-Site Contaminants

Depending on site-specific contaminants, various protective programs must be implemented prior to soil sampling. The site Health and Safety Plan should be reviewed with specific emphasis placed on a protection program planned for direct-contact tasks. Standard safe operating practices should be followed, including minimization of contact with potential contaminants in both the vapor phase and solid matrix by using both respirators and disposable clothing.

Use appropriate safe work practices for the type of contaminant expected (or determined from previous sampling efforts):

- Particulate or Metals Contaminants
 - Avoid skin contact with, and ingestion of, soils and dusts.
 - Use protective gloves.

- Volatile Organic Contaminants
 - Pre-survey the site with an HNu 101 or OVA 128 prior to collecting soil samples.
 - If monitoring results indicate organic constituents, sampling activities may be conducted in Level C protection. At a minimum, skin protection will be afforded by disposable protective clothing.

13. References

ASTM D 1586-67 (reapproved 1974), ASTM Committee on Standards, Philadelphia, PA.

ASTM D 1586-84, Penetration Test and Split Barrel Sampling of Soils.

Barth, D. S. and B. J. Mason, 1984, *Soil Sampling Quality Assurance User's Guide*, EPA-600/4-84-043.



TITLE: SOIL SAMPLING

CATEGORY: ENV 3.13

REVISED: August 1997

de Vera, E. R., B. P. Simmons, R. D. Stephen, and D. L. Storm, 1980, *Samplers and Sampling Procedures for Hazardous Waste Streams*, EPA-600/2-80-018.

Ecology and Environment, Inc., 1990, *Standard Operating Procedures*: “Equipment Decontamination,” and “Sample Packaging and Shipping.”

Mason, B. J., 1983, *Preparation of Soil Sampling Protocol: Technique and Strategies*, EPA-600/4-83-020.

U.S. Environmental Protection Agency (EPA), 1984, *Characterization of Hazardous Waste Sites – A Methods Manual: Volume II, Available Sampling Methods*, (2nd ed.), 1984, EPA-600/4-84-076.

_____, 1991, *Removal Program Representative Sampling Guidance: Volume I – Soil*, (Interim Final), EPA-9360.4-10.

_____, 1984, *Characterization of Hazardous Waste Sites – A Methods Manual: Volume I, Site Investigations*, Section 7: Environmental Monitoring Systems Laboratory, Las Vegas, Nevada, EPA/600/4-84/075.

_____, February 1989, *Methods for Evaluating the Attainment of Cleanup Standards: Volume I, Soils and Solid Media*, EPA/230/02-89/042.



TITLE:	SOIL SAMPLING	
CATEGORY:	ENV 3.13	REVISED: August 1997

A SAMPLING AUGERS

A. Sampling Augers



(a)
Ship Auger



(b)
Closed-Spiral Auger



(c)
Open-Spiral Auger

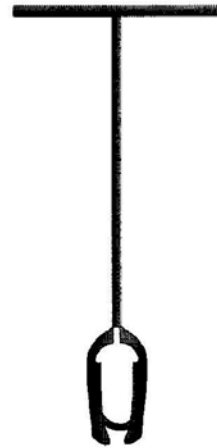

(d)
Iwan Auger



TITLE:	SOIL SAMPLING	
CATEGORY:	ENV 3.13	REVISED: August 1997

B SAMPLING TRIER

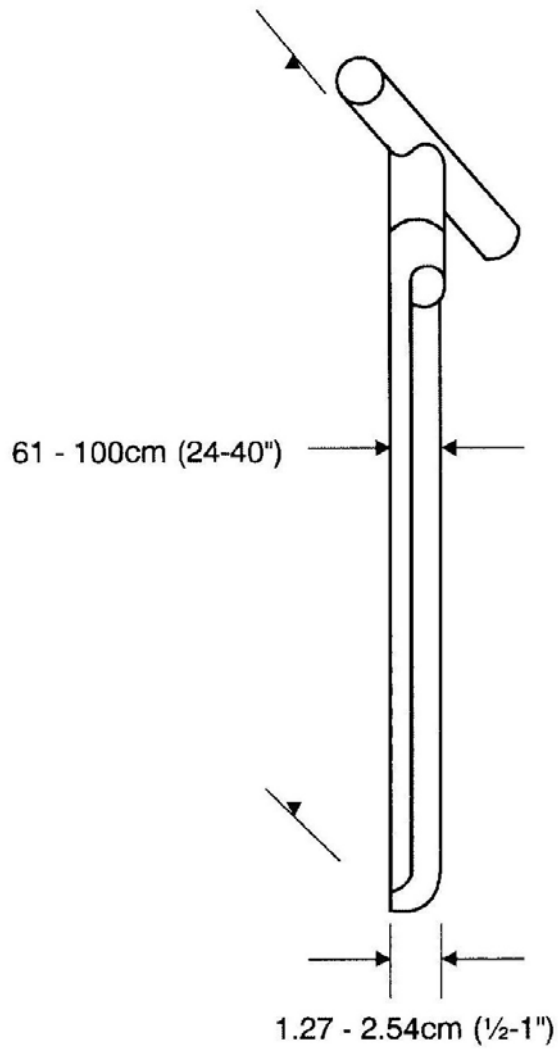



TITLE:	SOIL SAMPLING	
CATEGORY:	ENV 3.13	REVISED: August 1997

C SPLIT-SPOON SAMPLER

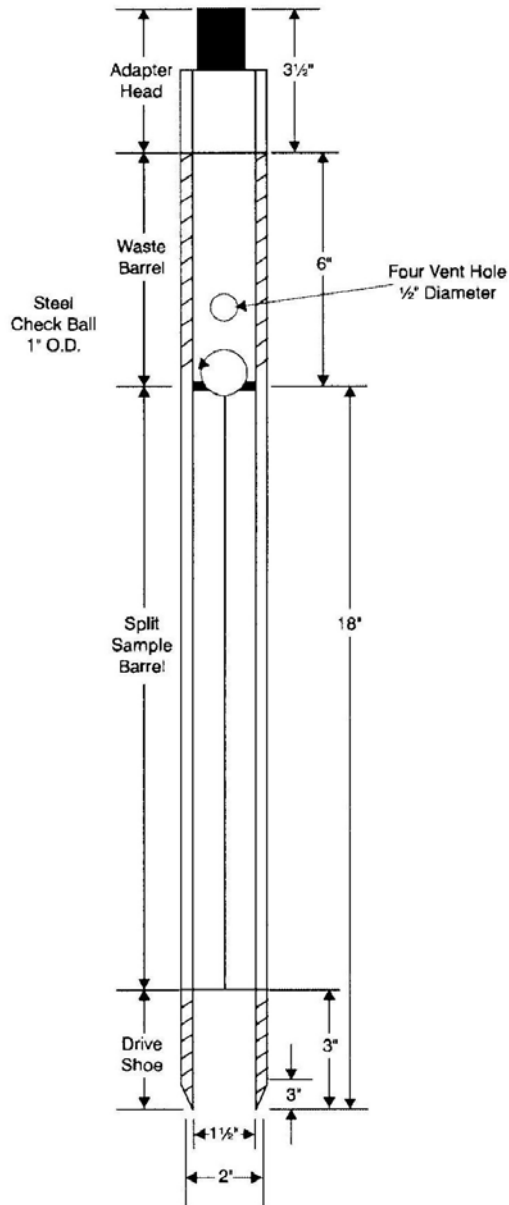



Title:	SAMPLING EQUIPMENT DECONTAMINATION
Category:	ENV 3.15
Revised:	March 1999

STANDARD OPERATING PROCEDURE

SAMPLING EQUIPMENT DECONTAMINATION

© 1999 Ecology and Environment, Inc.

ecology and environment, inc.

368 Pleasant View Drive / Lancaster, New York 14086 / (716) 684-8060



TITLE: SAMPLING EQUIPMENT DECONTAMINATION

CATEGORY: ENV 3.15

REVISED: March 1999

None of the information contained in this Ecology and Environment, Inc., (E & E) publication is to be construed as granting any right, by implication or otherwise, for the manufacture, sale, or use in connection with any method, apparatus, or product covered by letters patent, nor as ensuring anyone against liability for infringement of letters patent.

Anyone wishing to use this E & E publication should first seek permission from the company. Every effort has been made by E & E to ensure the accuracy and reliability of the information contained in the document; however, the company makes no representations, warranty, or guarantee in connection with this E & E publication and hereby expressly disclaims any liability or responsibility for loss or damage resulting from its use; for any violation of any federal, state, or municipal regulation with which this E & E publication may conflict; or for the infringement of any patent resulting from the use of the E & E publication.



TITLE:	SAMPLING EQUIPMENT DECONTAMINATION		
CATEGORY:	ENV 3.15	REVISED:	March 1999

TABLE OF CONTENTS

<u>Section</u>	<u>Page</u>
1. Scope and Application	1
2. Method Summary.....	1
3. Interferences.....	1
4. Equipment/Apparatus	2
5. Reagents	3
6. Procedures.....	3
6.1 Abrasive Cleaning Methods.....	5
6.2 Non-abrasive Cleaning Methods.....	5
6.3 Field Sampling Equipment Cleaning Procedures	7
7. Quality Assurance/Quality Control.....	8
8. Health and Safety	9
9. References.....	9



TITLE:	SAMPLING EQUIPMENT DECONTAMINATION		
CATEGORY:	ENV 3.15	REVISED:	March 1999

LIST OF TABLES

<u>Table</u>		<u>Page</u>
1	Decontamination Solvents	8



TITLE: SAMPLING EQUIPMENT DECONTAMINATION

CATEGORY: ENV 3.15

REVISED: March 1999

1. Scope and Application

The purpose of this procedure is to provide a description of methods for preventing or reducing cross-contamination and general guidelines for designing and selecting decontamination procedures for use at potential hazardous waste sites. The decontamination procedures chosen will prevent introduction and cross-contamination of suspected contaminants in environmental samples, and will protect the health and safety of site personnel.

2. Method Summary

Removing or neutralizing contaminants that have accumulated on personnel and equipment ensures protection of personnel from permeating substances, reduces/eliminates transfer of contaminants to clean areas, prevents the mixing of incompatible substances, and minimizes the likelihood of sample contamination.

Cross-contamination can be removed by physical decontamination procedures. The abrasive and non-abrasive methods include the use of brushes, high pressure water, air and wet blasting, and high pressure Freon cleaning. These methods should be followed by a wash/rinse process using appropriate cleaning solutions. A general protocol for cleaning with solutions is as follows:

1. Physical removal.
2. Non-phosphate detergent plus tap water.
3. Tap water.
4. 10% nitric acid.
5. Distilled/deionized water rinse.
6. Solvent rinse.
7. Total air dry.
8. Triple rinse with distilled/deionized water.

This procedure can be expanded to include additional or alternate solvent rinses that will remove specified target compounds if required by site-specific work plans (WP) or as directed by a particular client.

3. Interferences

The use of distilled/deionized water commonly available from commercial vendors may be acceptable for decontamination of sampling equipment provided that it has been verified by laboratory analysis to be analyte-free distilled/deionized water. Distilled water available from local grocery stores and pharmacies is generally not acceptable for final decontamination rinses. Contaminant-free deionized water is available from commercial vendors and may be shipped directly to the site or your hotel.



TITLE: SAMPLING EQUIPMENT DECONTAMINATION

CATEGORY: ENV 3.15

REVISED: March 1999

The use of an untreated potable water supply is not an acceptable substitute for tap water. Tap water may be used from any municipal water treatment system.

4. Equipment/Apparatus

The following are standard materials and equipment used as a part of the decontamination process:

- Appropriate protective clothing;
- Air purifying respirator (APR);
- Field log book;
- Non-phosphate detergent;
- Selected high purity, contaminant-free solvents;
- Long-handled brushes;
- Drop cloths (plastic sheeting);
- Trash containers;
- Paper towels;
- Galvanized tubs or equivalent (e.g., baby pools);
- Tap water;
- Contaminant-free distilled/deionized water;
- Metal/plastic container for storage and disposal of contaminated wash solutions;
- Pressurized sprayers, H₂O;
- Pressurized sprayers, solvents;
- Trash bags;
- Aluminum foil;
- Sample containers;



TITLE: SAMPLING EQUIPMENT DECONTAMINATION

CATEGORY: ENV 3.15

REVISED: March 1999

- Safety glasses or splash shield; and
- Emergency eyewash bottle.

5. Reagents

There are no reagents used in this procedure aside from decontamination solutions used for the equipment. The type of decontamination solution to be used shall depend upon the type and degree of contamination present and as specified in the project/site-specific Quality Assurance Project Plan (QAPP).

In general, the following solvents are utilized for decontamination purposes:

- 10% nitric acid wash (reagent grade nitric acid diluted with deionized/distilled water – 1 part acid to 10 parts water)^a;
- Acetone (pesticide grade)^b ;
- Hexane (pesticide grade)^b;
- Methanol; and
- Methylene chloride^b.

^a Only if sample is to be analyzed for trace metals.

^b Only if sample is to be analyzed for organics requiring specific or specialized decontamination procedures. These solvents must be kept away from samples in order to avoid contamination by decon solvents.

6. Procedures

Decontamination is the process of removing or neutralizing contaminants that have accumulated on both personnel and equipment. Specific procedures in each case are designed accordingly and may be identified in either the Health and Safety Plan (HSP), WP, QAPP, or all three.

As part of the HSP, a personnel decontamination plan should be developed and set up before any personnel or equipment enters the areas of potential contamination. Decontamination procedures for equipment will be specified in the WP and the associated QAPP. These plans should include:

- Number and layout of decontamination stations;
- Decontamination equipment needed (see Section 4);



TITLE: SAMPLING EQUIPMENT DECONTAMINATION

CATEGORY: ENV 3.15

REVISED: March 1999

- Appropriate decontamination methods;
- Procedures to prevent contamination of clean areas;
- Methods and procedures to minimize worker contact with contaminants during removal of protective clothing;
- Methods and procedures to prevent cross-contamination of samples and maintain sample integrity and sample custody; and
- Methods for disposal of contaminated clothing, equipment, and solutions.

Revisions to these plans may be necessary for health and safety when the types of protective clothing, site conditions, or on-site hazards are reassessed based on new information.

Prevention of Contamination

Several procedures can be established to minimize contact with waste and the potential for contamination. For example:

- Employing work practices that minimize contact with hazardous substances (e.g., avoid areas of obvious contamination, avoid touching potentially hazardous substances);
- Use of remote sampling, handling, and container-opening techniques;
- Covering monitoring and sampling equipment with plastic or other protective material;
- Use of disposable outer garments and disposable sampling equipment with proper containment of these disposable items;
- Use of disposable towels to clean the outer surfaces of sample bottles before and after sample collection; and
- Encasing the source of contaminants with plastic sheeting or overpacks.

Proper procedures for dressing prior to entrance into contaminated areas will minimize the potential for contaminants to bypass the protective clothing. Generally, all fasteners (zippers, buttons, snaps, etc.) should be used, gloves and boots tucked under or over sleeves and pant legs, and all junctures taped (see the Health and Safety Plan for these procedures).



TITLE: SAMPLING EQUIPMENT DECONTAMINATION

CATEGORY: ENV 3.15

REVISED: March 1999

Decontamination Methods

All personnel, samples, and equipment leaving the contaminated area of a site must be decontaminated to remove any chemicals or infectious organisms that may have adhered to them. Various decontamination methods will either physically remove, inactivate by chemical detoxification/disinfection/sterilization, or remove contaminants by both physical and chemical means.

In many cases, gross contamination can be removed by physical means. The physical decontamination techniques can be grouped into two categories: abrasive methods and non-abrasive methods.

6.1 Abrasive Cleaning Methods

Abrasive cleaning methods work by rubbing and wearing away the top layer of the surface containing the contaminant. The following reviews the available abrasive methods.

Mechanical

Mechanical methods include using brushes with metal, nylon, or natural bristles. The amount and type of contaminants removed will vary with the hardness of bristles, length of time brushing, and degree of brush contact. Material may also be removed by using appropriate tools to scrape, pry, or otherwise remove adhered materials.

Air Blasting

Air blasting equipment uses compressed air to force abrasive material through a nozzle at high velocities. The distance between nozzle and surface cleaned, air pressure, and time of air blasting dictate cleaning efficiency. The method's disadvantages are its inability to control the exact amount of material removed and its large amount of waste generated.

Wet Blasting

Wet blast cleaning involves the use of a suspended fine abrasive. The abrasive/water mixture is delivered by compressed air to the contaminated area. By using very fine abrasives, the amount of materials removed can be carefully controlled.

6.2 Non-abrasive Cleaning Methods

Non-abrasive cleaning methods work by either dissolution or by forcing the contaminant off a surface with pressure. In general, less of the equipment surface is removed using non-abrasive methods.



TITLE: SAMPLING EQUIPMENT DECONTAMINATION

CATEGORY: ENV 3.15

REVISED: March 1999

High-Pressure Water

This method consists of a high-pressure pump, an operator controlled directional nozzle, and high-pressure hose. Operating pressure usually ranges from 340 to 680 psi, which relates to flow rates of 20 to 140 lpm.

Steam Cleaning

This method uses water delivered at high pressure and high temperature in order to remove accumulated solids and/or oils.

Ultra-High-Pressure Water

This system produces a water jet from 1,000 to 4,000 atm. This ultra-high-pressure spray can remove tightly-adhered surface films. The water velocity ranges from 500 m/sec. (1,000 atm) to 900 m/sec. (4,000 atm). Additives can be used to enhance the cleaning action, if approved by the QAPP for the project.

High-Pressure Freon Cleaning

Freon cleaning is a very effective method for cleaning cloth, rubber, plastic, and external/internal metal surfaces. Freon 113 (trichlorotrifluoroethane) is dense, chemically stable, relatively non-toxic, and leaves no residue. The vapor is easily removed from the air by activated charcoal. A high pressure (1,000 atm) jet of liquid Freon 113 is directed onto the surface to be cleaned. The Freon can be collected in a sump, filtered, and reused.

Physical removal of gross contamination should be followed by a wash/rinse process using cleaning solutions. One or more of the following methods utilize cleaning solutions.

Dissolving

Removal of surface contaminants can be accomplished by chemically dissolving them, although the solvent must be compatible with the equipment and protective clothing. Organic solvents include alcohols, ethers, ketones, aromatics, straight-chain alkanes, and common petroleum products. Halogenated solvents are generally incompatible with protective clothing and are toxic. Table 1 provides a general guide to the solubility of contaminant categories in four types of solvents.

Surfactants

Surfactants reduce adhesion forces between contaminants and the surface being cleaned and prevents reposition of the contaminants. Non-phosphate detergents dissolved in tap water is an acceptable surfactant solution.



TITLE: SAMPLING EQUIPMENT DECONTAMINATION

CATEGORY: ENV 3.15

REVISED: March 1999

Rinsing

Contaminants are removed and rinsing through dilution, physical attraction, and solubilization.

Disinfection/Sterilization

Disinfectants are a practical means of inactivating infectious agents. Unfortunately, standard sterilization methods are impractical for large equipment and personal protective clothing.

6.3 Field Sampling Equipment Cleaning Procedures

The following steps for equipment cleaning should be followed for general field sampling activities.

1. Physical removal (abrasive or non-abrasive methods).
2. Scrub with non-phosphate detergent plus tap water.
3. Tap water rinse.
4. 10% nitric acid (required during sampling for inorganics only).
5. Distilled/deionized water rinse.
6. Solvent rinse (required during sampling for organics only).
7. Total air dry (required during sampling for organics only).
8. Triple rinse with distilled/deionized water.

Table 1 lists solvent rinses which may be required for elimination of particular chemicals. After each solvent rinse, the equipment should be air-dried and triple-rinsed with distilled/deionized water.

Solvent rinses are not necessarily required when organics are not a contaminant of concern. Similarly, an acid rinse is not necessarily required if analysis does not include inorganics.

NOTE: Reference the appropriate analytical procedure for specific decontamination solutions required for adequate removal of the contaminants of concern.

Sampling equipment that requires the use of plastic or teflon tubing should be disassembled, cleaned, and the tubing replaced with clean tubing, if necessary, before commencement of sampling or between sampling locations.



TITLE:	SAMPLING EQUIPMENT DECONTAMINATION	
CATEGORY:	ENV 3.15	REVISED: March 1999

Table 1 Decontamination Solvents

Solvent	Soluble Contaminants
Water	Low-chain compounds Salts Some organic acids and other polar compounds
Dilute Bases For example: <ul style="list-style-type: none"> ■ detergent ■ soap 	Acidic compounds Phenol Thiols Some nitro and sulfonic compounds
Organic Solvents: For example: <ul style="list-style-type: none"> ■ alcohols (methanol) ■ ethers ■ ketones ■ aromatics ■ straight-chain alkanes (e.g., hexane) ■ common petroleum products (e.g., fuel oil, kerosene) 	Nonpolar compounds (e.g., some organic compounds)

WARNING: Some organic solvents can permeate and/or degrade the protective clothing.

7. Quality Assurance/Quality Control

QA/QC samples are intended to provide information concerning possible cross-contamination during collection, handling, preparation, and packing of samples from field locations for subsequent review and interpretation. A field blank (rinsate blank) provides an additional check on possible sources of contamination from ambient air and from sampling instruments used to collect and transfer samples into sample containers.

A field blank (rinsate blank) consists of a sample of analyte-free water passed through/over a precleaned/decontaminated sampling device and placed in a clean area to attempt to simulate a worst-case condition regarding ambient air contributions to sample contamination.

Field blanks should be collected at a rate of one per day per sample matrix even if samples are not shipped that day. The field blanks should return to the lab with the trip blanks originally sent to the field and be packed with their associated matrix.

The field blank places a mechanism of control on equipment decontamination, sample handling, storage, and shipment procedures. It is also indicative of ambient conditions and/or equipment conditions that may affect the quality of the samples.

Holding times for field blanks analyzed by CLP methods begin when the blank is received in the laboratory (as documented on the chain of parameters and associated analytical methods).

Holding times for samples and blanks analyzed by SW-846 or the 600 and 500 series begins at the time of sample collection.



TITLE: SAMPLING EQUIPMENT DECONTAMINATION

CATEGORY: ENV 3.15

REVISED: March 1999

8. Health and Safety

Decontamination can pose hazards under certain circumstances even though performed to protect health and safety. Hazardous substances may be incompatible with decontamination methods (i.e., the method may react with contaminants to produce heat, explosion, or toxic products). Decontamination methods may be incompatible with clothing or equipment (e.g., some solvents can permeate and/or degrade protective clothing). Also, a direct health hazard to workers can be posed from chemical decontamination solutions that may be hazardous if inhaled or may be flammable.

The decontamination solutions must be determined to be compatible before use. Any method that permeates, degrades, or damages personal protective equipment should not be used. If decontamination methods do pose a direct health hazard, measures should be taken to protect personnel or modified to eliminate the hazard.

All site-specific safety procedures should be followed for the cleaning operation. At a minimum, the following precautions should be taken:

1. Safety glasses with splash shields or goggles, neoprene gloves, and laboratory apron should be worn.
2. All solvent rinsing operations should be conducted under a fume hood or in open air.
3. No eating, smoking, drinking, chewing, or any hand-to-mouth contact is permitted.

9. References

Field Sampling Procedures Manual, New Jersey Department of Environmental Protection, 1988.

A Compendium of Superfund Field Operations Methods, EPA 540/p-87/001.

Engineering Support Branch Standard Operating Procedures and Quality Assurance Manual, USEPA Region IV, April 1, 1986.

Occupational Safety and Health Guidance Manual for Hazardous Waste Site Activities, NIOSH/OSHA/USCG/EPA, October 1985.

Ecology and Environment - Lakewood
3700 Industry Ave, Suite 102
Lakewood, CA 90712
Attention: Mike Schwennesen

Project ID: T02-09-11-08-0005

Report Number: PUI0975

Sampled: 09/15/11
Received: 09/16/11

TOTAL METALS

Analyte	Method	Batch	Reporting Limit	Sample Result	Dilution Factor	Date Extracted	Date Analyzed	Data Qualifiers
Sample ID: PUI0975-01 (1KMHSR-OFS-148-001-002 - Soil)								
Reporting Units: mg/kg								
Arsenic	EPA 6010B	11I0581	5.0	180	0.996	9/16/2011	9/18/2011	
Lead	EPA 6010B	11I0581	5.0	760	0.996	9/16/2011	9/18/2011	
Sample ID: PUI0975-02 (1KMHSR-OFS-148-002-002 - Soil)								
Reporting Units: mg/kg								
Arsenic	EPA 6010B	11I0581	5.0	200	0.988	9/16/2011	9/18/2011	
Lead	EPA 6010B	11I0581	5.0	850	0.988	9/16/2011	9/18/2011	
Sample ID: PUI0975-03 (1KMHSR-OFS-148-003-002 - Soil)								
Reporting Units: mg/kg								
Arsenic	EPA 6010B	11I0581	5.0	29	0.968	9/16/2011	9/18/2011	
Lead	EPA 6010B	11I0581	5.0	67	0.968	9/16/2011	9/18/2011	
Sample ID: PUI0975-04 (1KMHSR-OFS-148-005-002 - Soil)								
Reporting Units: mg/kg								
Arsenic	EPA 6010B	11I0581	5.0	21	0.969	9/16/2011	9/18/2011	
Lead	EPA 6010B	11I0581	5.0	61	0.969	9/16/2011	9/18/2011	
Sample ID: PUI0975-05 (1KMHSR-OFS-111-001-002 - Soil)								
Reporting Units: mg/kg								
Arsenic	EPA 6010B	11I0581	5.0	170	0.996	9/16/2011	9/18/2011	
Lead	EPA 6010B	11I0581	5.0	460	0.996	9/16/2011	9/18/2011	

BLIND
DUPLICATES
TO LAB
RS
10/3/12

MA 1/12/12

TestAmerica Phoenix
Erik Vaasen
Project Manager

The results pertain only to the samples tested in the laboratory. This report shall not be reproduced, except in full, without written permission from TestAmerica.

Ecology and Environment - Lakewood
3700 Industry Ave, Suite 102
Lakewood, CA 90712
Attention: Mike Schwennesen

Project ID: T02-09-11-08-0005

Report Number: PUJ1827

Sampled: 10/29/11

Received: 10/29/11

INORGANICS

Analyte	Method	Batch	Reporting Limit	Sample Result	Dilution Factor	Date Extracted	Date Analyzed	Data Qualifiers
Sample ID: PUJ1827-04 (1KMHSR-OFS-002-004-072 - Soil)								
Reporting Units: mg/kg								
Cyanide	SW 9010C/9014	11K0029	0.40	1.9	J 0.979	11/1/2011	11/1/2011	
Sample ID: PUJ1827-05 (1KMHSR-OFS-002-005-072 - Soil)								
Reporting Units: mg/kg								
Cyanide	SW 9010C/9014	11K0029	0.40	2.6	J 1.01	11/1/2011	11/1/2011	

BLIND
DUPLICATES
TO LAB
VS
1/25/12

[Handwritten signature] 1/25/12

TestAmerica Phoenix

Erik Aasen
Project Manager

9 of 299

The results pertain only to the samples tested in the laboratory. This report shall not be reproduced, except in full, without written permission from TestAmerica.

PUJ1827 <Page 4 of 11>

Ecology and Environment - Lakewood
3700 Industry Ave, Suite 102
Lakewood, CA 90712
Attention: Mike Schwennesen

Project ID: T02-09-11-08-0005

Report Number: PUK0708

Sampled: 11/09/11
Received: 11/09/11

TOTAL METALS

Analyte	Method	Batch	Reporting Limit	Sample Result	Dilution Factor	Date Extracted	Date Analyzed	Data Qualifiers
Sample ID: PUK0708-01 (IKMHSR-OFS-002-014-002 - Soil)								
Reporting Units: mg/kg								
Arsenic	EPA 6010B	11K0374	5.0	67 J	0.996	11/9/2011	11/11/2011	BLIND DUPLICATES TO LAB MS 1/29/12
Lead	EPA 6010B	11K0374	5.0	65	0.996	11/9/2011	11/11/2011	
Sample ID: PUK0708-02 (IKMHSR-OFS-002-015-002 - Soil)								
Reporting Units: mg/kg								
Arsenic	EPA 6010B	11K0374	5.0	70 J	0.998	11/9/2011	11/11/2011	MS 1/29/12
Lead	EPA 6010B	11K0374	5.0	60	0.998	11/9/2011	11/11/2011	
Sample ID: PUK0708-03 (IKMHSR-OFS-002-016-002 - Soil)								
Reporting Units: mg/kg								
Arsenic	EPA 6010B	11K0374	5.0	50 J	0.997	11/9/2011	11/11/2011	MS 1/25/12
Lead	EPA 6010B	11K0374	5.0	32	0.997	11/9/2011	11/11/2011	

TestAmerica Phoenix

Erik Aasen
Project Manager

7 of 129

The results pertain only to the samples tested in the laboratory. This report shall not be reproduced, except in full, without written permission from TestAmerica.

PUK0708 <Page 2 of 5>

Ecology and Environment - Lakewood
3700 Industry Ave, Suite 102
Lakewood, CA 90712
Attention: Mike Schwennesen

Project ID: T02-09-11-08-0005

Report Number: PUK0813

Sampled: 11/10/11
Received: 11/11/11

TOTAL METALS

Analyte	Method	Batch	Reporting Limit	Sample Result	Dilution Factor	Date Extracted	Date Analyzed	Data Qualifiers
Sample ID: PUK0813-01 (IKMHSR-OFS-002-017-002 - Soil)								
Reporting Units: mg/kg								
Arsenic	EPA 6010B	11K0454	5.0	200 J	0.975	11/11/2011	11/14/2011	
Lead	EPA 6010B	11K0454	5.0	160	0.975	11/11/2011	11/14/2011	
Sample ID: PUK0813-02 (IKMHSR-OFS-002-018-002 - Soil)								
Reporting Units: mg/kg								
Arsenic	EPA 6010B	11K0454	5.0	22 J	0.958	11/11/2011	11/14/2011	
Lead	EPA 6010B	11K0454	5.0	9.1	0.958	11/11/2011	11/14/2011	
Sample ID: PUK0813-03 (IKMHSR-OFS-002-019-002 - Soil)								
Reporting Units: mg/kg								
Arsenic	EPA 6010B	11K0454	5.0	56 J	0.994	11/11/2011	11/14/2011	
Lead	EPA 6010B	11K0454	5.0	47	0.994	11/11/2011	11/14/2011	

[Handwritten Signature]
1/25/12

TestAmerica Phoenix

Erik Aasen
Project Manager

7 of 138

The results pertain only to the samples tested in the laboratory. This report shall not be reproduced, except in full, without written permission from TestAmerica.

PUK0813 <Page 2 of 5>

Ecology and Environment - Lakewood
3700 Industry Ave, Suite 102
Lakewood, CA 90712
Attention: Mike Schwennesen

Project ID: T02-09-11-08-0005
Report Number: PUJ1827

Sampled: 10/29/11
Received: 10/29/11

TOTAL METALS

Analyte	Method	Batch	Reporting Limit	Sample Result	Dilution Factor	Date Extracted	Date Analyzed	Data Qualifiers
Sample ID: PUJ1827-01 (1KMHSR-OFS-002-001-002 - Soil)								
Reporting Units: mg/kg								
Arsenic	EPA 6010B	11J1199	5.0	24	0.988	10/31/2011	11/4/2011	
Lead	EPA 6010B	11J1199	5.0	11	0.988	10/31/2011	11/1/2011	
Sample ID: PUJ1827-02 (1KMHSR-OFS-002-002-002 - Soil)								
Reporting Units: mg/kg								
Arsenic	EPA 6010B	11J1199	5.0	25	0.967	10/31/2011	11/4/2011	
Lead	EPA 6010B	11J1199	5.0	12	0.967	10/31/2011	11/1/2011	
Sample ID: PUJ1827-03 (1KMHSR-OFS-002-003-002 - Soil)								
Reporting Units: mg/kg								
Arsenic	EPA 6010B	11J1199	5.0	25	0.991	10/31/2011	11/4/2011	
Lead	EPA 6010B	11J1199	5.0	36	0.991	10/31/2011	11/1/2011	
Sample ID: PUJ1827-04 (1KMHSR-OFS-002-004-072 - Soil) <i>BLIND DUPLICATE w/ 002-005-072 11-29-12</i>								
Reporting Units: mg/kg								
Antimony	EPA 6010B	11J1199	5.0	40 J	1	10/31/2011	11/4/2011	
Arsenic	EPA 6010B	11J1199	5.0	5000	10	10/31/2011	11/17/2011	D2
Barium	EPA 6010B	11J1199	5.0	26	1	10/31/2011	11/1/2011	
Beryllium	EPA 6010B	11J1199	0.50	ND	1	10/31/2011	11/1/2011	
Cadmium	EPA 6010B	11J1199	0.50	120	1	10/31/2011	11/1/2011	
Chromium	EPA 6010B	11J1199	2.0	13	1	10/31/2011	11/1/2011	
Cobalt	EPA 6010B	11J1199	2.0	18	1	10/31/2011	11/1/2011	
Copper	EPA 6010B	11J1199	5.0	800	1	10/31/2011	11/1/2011	
Lead	EPA 6010B	11J1199	5.0	5100	1	10/31/2011	11/1/2011	
Mercury	EPA 7471A	11J1213	2.0	17	19.1	11/1/2011	11/1/2011	B7, D2
Molybdenum	EPA 6010B	11J1199	2.0	5.2	1	10/31/2011	11/1/2011	
Nickel	EPA 6010B	11J1199	2.0	14	1	10/31/2011	11/1/2011	
Selenium	EPA 6010B	11J1199	5.0	31	1	10/31/2011	11/1/2011	
Silver	EPA 6010B	11J1199	2.5	36	1	10/31/2011	11/1/2011	
Thallium	EPA 6010B	11J1199	5.0	ND	1	10/31/2011	11/1/2011	
Vanadium	EPA 6010B	11J1199	1.0	29	1	10/31/2011	11/1/2011	
Zinc	EPA 6010B	11J1199	1000	48000	100	10/31/2011	11/4/2011	D2

[Signature] 1/25/12

TestAmerica Phoenix
Erik Aasen
Project Manager

7 of 299

The results pertain only to the samples tested in the laboratory. This report shall not be reproduced, except in full, without written permission from TestAmerica.

Ecology and Environment - Lakewood
 3700 Industry Ave, Suite 102
 Lakewood, CA 90712
 Attention: Mike Schwennesen

Project ID: T02-09-11-08-0005

Report Number: PUJ1827

Sampled: 10/29/11
 Received: 10/29/11

TOTAL METALS

Analyte	Method	Batch	Reporting Limit	Sample Result	Dilution Factor	Date Extracted	Date Analyzed	Data Qualifiers
Sample ID: PUJ1827-05 (1KMHSR-OFS-002-005-072 - Soil)								
Reporting Units: mg/kg								
Antimony	EPA 6010B	11J1199	5.0	38 J	0.977	10/31/2011	11/4/2011	
Arsenic	EPA 6010B	11J1199	50	5300	9.77	10/31/2011	11/17/2011	D2
Barium	EPA 6010B	11J1199	5.0	32	0.977	10/31/2011	11/1/2011	
Beryllium	EPA 6010B	11J1199	0.50	ND	0.977	10/31/2011	11/1/2011	
Cadmium	EPA 6010B	11J1199	0.50	120	0.977	10/31/2011	11/1/2011	
Chromium	EPA 6010B	11J1199	2.0	15	0.977	10/31/2011	11/1/2011	
Cobalt	EPA 6010B	11J1199	2.0	19	0.977	10/31/2011	11/1/2011	
Copper	EPA 6010B	11J1199	5.0	950	0.977	10/31/2011	11/1/2011	
Lead	EPA 6010B	11J1199	5.0	5300	0.977	10/31/2011	11/1/2011	
Mercury	EPA 7471A	11J1213	2.0	10	21.2	11/1/2011	11/1/2011	B7, M4
Molybdenum	EPA 6010B	11J1199	2.0	5.5	0.977	10/31/2011	11/1/2011	
Nickel	EPA 6010B	11J1199	2.0	14	0.977	10/31/2011	11/1/2011	
Selenium	EPA 6010B	11J1199	5.0	29	0.977	10/31/2011	11/1/2011	
Silver	EPA 6010B	11J1199	2.5	35	0.977	10/31/2011	11/1/2011	
Thallium	EPA 6010B	11J1199	5.0	ND	0.977	10/31/2011	11/1/2011	
Vanadium	EPA 6010B	11J1199	1.0	33	0.977	10/31/2011	11/1/2011	
Zinc	EPA 6010B	11J1199	1000	44008	97.7	10/31/2011	11/4/2011	D2

BLIND DUPLICATE W/ 002-004-072

MS 1-29-12

m. A. 1/25/12

TestAmerica Phoenix

Erik Vaasen
 Project Manager

8 of 299

The results pertain only to the samples tested in the laboratory. This report shall not be reproduced, except in full, without written permission from TestAmerica.

PUJ1827 <Page 3 of 11>

Ecology and Environment - Lakewood
3700 Industry Ave, Suite 102
Lakewood, CA 90712
Attention: Mindy Song

Project ID: T02-09-11-08-0005

Report Number: PUI1581

Sampled: 09/26/11
Received: 09/27/11

TOTAL METALS

Analyte	Method	Batch	Reporting Limit	Sample Result	Dilution Factor	Date Extracted	Date Analyzed	Data Qualifiers
Sample ID: PUI1581-01 (IKMHSR-OFS-111-009-002 - Soil)								
Reporting Units: mg/kg								
Arsenic	EPA 6010B	11I0976	5.0	160	0.996	9/27/2011	9/28/2011	M3
Lead	EPA 6010B	11I0976	5.0	610	0.996	9/27/2011	9/28/2011	M3
Sample ID: PUI1581-02 (IKMHSR-OFS-111-006-002 - Soil)								
Reporting Units: mg/kg								
Arsenic	EPA 6010B	11I0976	5.0	120	1	9/27/2011	9/28/2011	
Lead	EPA 6010B	11I0976	5.0	390	1	9/27/2011	9/28/2011	
Sample ID: PUI1581-03 (IKMHSR-OFS-306-003-002 - Soil)								
Reporting Units: mg/kg								
Arsenic	EPA 6010B	11I0976	5.0	29	0.997	9/27/2011	9/28/2011	
Lead	EPA 6010B	11I0976	5.0	59	0.997	9/27/2011	9/28/2011	
Sample ID: PUI1581-04 (IKMHSR-OFS-306-004-002 - Soil)								
Reporting Units: mg/kg								
Arsenic	EPA 6010B	11I0976	5.0	52	0.996	9/27/2011	9/28/2011	
Lead	EPA 6010B	11I0976	5.0	180	0.996	9/27/2011	9/28/2011	

[Handwritten Signature] 1/20/12

TestAmerica Phoenix

Erik Aasen
Project Manager

7 of 132

Ecology and Environment - Lakewood
3700 Industry Ave, Suite 102
Lakewood, CA 90712
Attention: Mike Schwennesen

Project ID: T02-09-11-08-0005
Report Number: PUI1139

Sampled: 09/19/11
Received: 09/20/11

TOTAL METALS

Analyte	Method	Batch	Reporting Limit	Sample Result	Dilution Factor	Date Extracted	Date Analyzed	Data Qualifiers
Sample ID: PUI1139-01 (1KMHSR-OFS-111-002-002 - Soil)								
Reporting Units: mg/kg								
Arsenic	EPA 6010B	11I0710	5.0	84	0.997	9/20/2011	9/21/2011	
Lead	EPA 6010B	11I0710	5.0	460	0.997	9/20/2011	9/21/2011	
Sample ID: PUI1139-02 (1KMHSR-OFS-111-003-002 - Soil)								
Reporting Units: mg/kg								
Arsenic	EPA 6010B	11I0710	5.0	160	0.995	9/20/2011	9/21/2011	
Lead	EPA 6010B	11I0710	5.0	620	0.995	9/20/2011	9/21/2011	
Sample ID: PUI1139-03 (1KMHSR-OFS-111-004-002 - Soil)								
Reporting Units: mg/kg								
Arsenic	EPA 6010B	11I0710	5.0	180	0.997	9/20/2011	9/21/2011	
Lead	EPA 6010B	11I0710	5.0	880	0.997	9/20/2011	9/21/2011	
Sample ID: PUI1139-04 (1KMHSR-OFS-111-005-002 - Soil)								
Reporting Units: mg/kg								
Arsenic	EPA 6010B	11I0710	5.0	190	0.997	9/20/2011	9/21/2011	
Lead	EPA 6010B	11I0710	5.0	820	0.997	9/20/2011	9/21/2011	

MS 1/12/12

TestAmerica Phoenix

Erik Aasen
Project Manager

7 of 101

The results pertain only to the samples tested in the laboratory. This report shall not be reproduced, except in full, without written permission from TestAmerica.

PUI1139 <Page 2 of 5>

Ecology and Environment - Lakewood
3700 Industry Ave, Suite 102
Lakewood, CA 90712
Attention: Mindy Song

Project ID: T02-09-11-08-0005

Report Number: PUJ0935

Sampled: 10/07/11-10/13/11
Received: 10/14/11

TOTAL METALS

Analyte	Method	Batch	Reporting Limit	Sample Result	Dilution Factor	Date Extracted	Date Analyzed	Data Qualifiers
Sample ID: PUJ0935-01 (IKMHSR-OFS-118-003-002 - Soil)				Sampled: 10/07/11				
Reporting Units: mg/kg								
Arsenic	EPA 6010B	11J0706	5.0	250	0.998	10/18/2011	10/19/2011	
Lead	EPA 6010B	11J0706	5.0	820	J 0.998	10/18/2011	10/19/2011	
Sample ID: PUJ0935-02 (IKMHSR-OFS-118-004-002 - Soil)				Sampled: 10/07/11				
Reporting Units: mg/kg								
Arsenic	EPA 6010B	11J0706	5.0	98	0.998	10/18/2011	10/19/2011	
Lead	EPA 6010B	11J0706	5.0	620	J 0.998	10/18/2011	10/19/2011	
Sample ID: PUJ0935-03 (IKMHSR-OFS-118-005-002 - Soil)				Sampled: 10/07/11				
Reporting Units: mg/kg								
Arsenic	EPA 6010B	11J0706	5.0	74	0.999	10/18/2011	10/19/2011	M1
Lead	EPA 6010B	11J0706	5.0	470	J 0.999	10/18/2011	10/19/2011	M2
Sample ID: PUJ0935-04 (IKMHSR-OFS-133-001-002 - Soil)				Sampled: 10/11/11				
Reporting Units: mg/kg								
Arsenic	EPA 6010B	11J0706	5.0	320	0.999	10/18/2011	10/19/2011	
Lead	EPA 6010B	11J0706	5.0	1000	J 0.999	10/18/2011	10/19/2011	
Sample ID: PUJ0935-05 (IKMHSR-OFS-133-003-002 - Soil)				Sampled: 10/12/11				
Reporting Units: mg/kg								
Arsenic	EPA 6010B	11J0706	5.0	240	1	10/18/2011	10/19/2011	
Lead	EPA 6010B	11J0706	5.0	720	J 1	10/18/2011	10/19/2011	
Sample ID: PUJ0935-06 (IKMHSR-OFS-133-002-002 - Soil)				Sampled: 10/13/11				
Reporting Units: mg/kg								
Arsenic	EPA 6010B	11J0706	5.0	71	0.997	10/18/2011	10/19/2011	
Lead	EPA 6010B	11J0706	5.0	220	J 0.997	10/18/2011	10/19/2011	
Sample ID: PUJ0935-07 (Arrowhead-Common-007 - Soil)				Sampled: 10/13/11				
Reporting Units: mg/kg								
Arsenic	EPA 6010B	11J0706	5.0	12	0.997	10/18/2011	10/19/2011	
Barium	EPA 6010B	11J0706	5.0	77	0.997	10/18/2011	10/19/2011	
Cadmium	EPA 6010B	11J0706	0.50	ND	0.997	10/18/2011	10/19/2011	
Chromium	EPA 6010B	11J0706	2.0	5.5	J 0.997	10/18/2011	10/19/2011	
Lead	EPA 6010B	11J0706	5.0	7.6	J 0.997	10/18/2011	10/19/2011	
Mercury	EPA 7471A	11J0718	0.10	ND	0.934	10/19/2011	10/20/2011	
Selenium	EPA 6010B	11J0706	5.0	ND	0.997	10/18/2011	10/19/2011	
Silver	EPA 6010B	11J0706	2.5	ND	0.997	10/18/2011	10/19/2011	

BLIND DUPLICATES TO LAB IS 1-22-12

Mindy Song 1/25/12

TestAmerica Phoenix

Erik Aasen
Project Manager

8 of 213

The results pertain only to the samples tested in the laboratory. This report shall not be reproduced, except in full, without written permission from TestAmerica.

PUJ0935 <Page 3 of 10>

Ecology and Environment - Lakewood
 3700 Industry Ave, Suite 102
 Lakewood, CA 90712
 Attention: Mindy Song

Project ID: T02-09-11-08-0005

Report Number: PUJ0935

Sampled: 10/07/11-10/13/11
 Received: 10/14/11

TOTAL METALS

Analyte	Method	Batch	Reporting Limit	Sample Result	Dilution Factor	Date Extracted	Date Analyzed	Data Qualifiers
Sample ID: PUJ0935-08 (Arrowhead-Common-008 - Soil)				Sampled: 10/13/11				
Reporting Units: mg/kg								
Arsenic	EPA 6010B	11J0706	5.0	12	0.998	10/18/2011	10/19/2011	
Barium	EPA 6010B	11J0706	5.0	99	0.998	10/18/2011	10/19/2011	
Cadmium	EPA 6010B	11J0706	0.50	ND	0.998	10/18/2011	10/19/2011	
Chromium	EPA 6010B	11J0706	2.0	7.3 J	0.998	10/18/2011	10/19/2011	
Lead	EPA 6010B	11J0706	5.0	8.0 J	0.998	10/18/2011	10/19/2011	
Mercury	EPA 7471A	11J0718	0.10	ND	0.93	10/19/2011	10/20/2011	
Selenium	EPA 6010B	11J0706	5.0	ND	0.998	10/18/2011	10/19/2011	
Silver	EPA 6010B	11J0706	2.5	ND	0.998	10/18/2011	10/19/2011	
Sample ID: PUJ0935-09 (Arrowhead-Common-009 - Soil)				Sampled: 10/13/11				
Reporting Units: mg/kg								
Arsenic	EPA 6010B	11J0706	5.0	15	0.999	10/18/2011	10/19/2011	
Barium	EPA 6010B	11J0706	5.0	110	0.999	10/18/2011	10/19/2011	
Cadmium	EPA 6010B	11J0706	0.50	ND	0.999	10/18/2011	10/19/2011	
Chromium	EPA 6010B	11J0706	2.0	7.9 J	0.999	10/18/2011	10/19/2011	
Lead	EPA 6010B	11J0706	5.0	9.6 J	0.999	10/18/2011	10/19/2011	
Mercury	EPA 7471A	11J0718	0.10	ND	0.992	10/19/2011	10/20/2011	
Selenium	EPA 6010B	11J0706	5.0	ND	0.999	10/18/2011	10/19/2011	
Silver	EPA 6010B	11J0706	2.5	ND	0.999	10/18/2011	10/19/2011	
Sample ID: PUJ0935-10 (Arrowhead-Common-010 - Soil)				Sampled: 10/13/11				
Reporting Units: mg/kg								
Arsenic	EPA 6010B	11J0706	5.0	14	0.997	10/18/2011	10/19/2011	
Barium	EPA 6010B	11J0706	5.0	110	0.997	10/18/2011	10/19/2011	
Cadmium	EPA 6010B	11J0706	0.50	ND	0.997	10/18/2011	10/19/2011	
Chromium	EPA 6010B	11J0706	2.0	7.9 J	0.997	10/18/2011	10/19/2011	
Lead	EPA 6010B	11J0706	5.0	8.9 J	0.997	10/18/2011	10/19/2011	
Mercury	EPA 7471A	11J0718	0.10	ND	1.01	10/19/2011	10/20/2011	
Selenium	EPA 6010B	11J0706	5.0	ND	0.997	10/18/2011	10/19/2011	
Silver	EPA 6010B	11J0706	2.5	ND	0.997	10/18/2011	10/19/2011	

Mindy Song 1/25/12

TestAmerica Phoenix

Erik Vaasen
 Project Manager

10 of 213

Ecology and Environment - Lakewood
 3700 Industry Ave, Suite 102
 Lakewood, CA 90712
 Attention: Mindy Song

Project ID: T02-09-11-08-0005

Report Number: PUJ0935

Sampled: 10/07/11-10/13/11
 Received: 10/14/11

TOTAL METALS

Analyte	Method	Batch	Reporting Limit	Sample Result	Dilution Factor	Date Extracted	Date Analyzed	Data Qualifiers
Sample ID: PUJ0935-11 (Arrowhead-Common-011 - Soil)				Sampled: 10/13/11				
Reporting Units: mg/kg								
Arsenic	EPA 6010B	11J0706	5.0	15	0.998	10/18/2011	10/19/2011	
Barium	EPA 6010B	11J0706	5.0	120	0.998	10/18/2011	10/19/2011	
Cadmium	EPA 6010B	11J0706	0.50	ND	0.998	10/18/2011	10/19/2011	
Chromium	EPA 6010B	11J0706	2.0	7.3 J	0.998	10/18/2011	10/19/2011	
Lead	EPA 6010B	11J0706	5.0	8.6 J	0.998	10/18/2011	10/19/2011	
Mercury	EPA 7471A	11J0718	0.10	ND	1.02	10/19/2011	10/20/2011	
Selenium	EPA 6010B	11J0706	5.0	ND	0.998	10/18/2011	10/19/2011	
Silver	EPA 6010B	11J0706	2.5	ND	0.998	10/18/2011	10/19/2011	

 1/25/12

TestAmerica Phoenix

Erik Aasen
 Project Manager

11 of 213

Ecology and Environment - Lakewood
3700 Industry Ave, Suite 102
Lakewood, CA 90712
Attention: Mike Schwennesen

Project ID: T02-09-11-08-0005 Iron King Mine - Humboldt Smelte

Report Number: PUI1073

Sampled: 09/17/11

Received: 09/19/11

TOTAL METALS

Analyte	Method	Batch	Reporting Limit	Sample Result	Dilution Factor	Date Extracted	Date Analyzed	Data Qualifiers
Sample ID: PUI1073-01 (IKMHSR-OFS-132-001-012 - Soil)								
Reporting Units: mg/kg								
Arsenic	EPA 6010B	1110654	5.0	100	0.996	9/19/2011	9/20/2011	
Lead	EPA 6010B	1110654	5.0	230	0.996	9/19/2011	9/20/2011	
Sample ID: PUI1073-02 (IKMHSR-OFS-132-002-012 - Soil)								
Reporting Units: mg/kg								
Arsenic	EPA 6010B	1110654	5.0	20	0.996	9/19/2011	9/20/2011	
Lead	EPA 6010B	1110654	5.0	52	0.996	9/19/2011	9/20/2011	
Sample ID: PUI1073-03 (IKMHSR-OFS-132-003-012 - Soil)								
Reporting Units: mg/kg								
Arsenic	EPA 6010B	1110654	5.0	130	0.999	9/19/2011	9/20/2011	
Lead	EPA 6010B	1110654	5.0	480	0.999	9/19/2011	9/20/2011	
Sample ID: PUI1073-04 (IKMHSR-OFS-132-004-012 - Soil)								
Reporting Units: mg/kg								
Arsenic	EPA 6010B	1110654	5.0	200	0.999	9/19/2011	9/20/2011	
Lead	EPA 6010B	1110654	5.0	1400	0.999	9/19/2011	9/20/2011	
Sample ID: PUI1073-05 (IKMHSR-OFS-132-005-012 - Soil)								
Reporting Units: mg/kg								
Arsenic	EPA 6010B	1110654	5.0	100	0.996	9/19/2011	9/20/2011	
Lead	EPA 6010B	1110654	5.0	270	0.996	9/19/2011	9/20/2011	
Sample ID: PUI1073-06 (IKMHSR-OFS-306-001-012 - Soil)								
Reporting Units: mg/kg								
Arsenic	EPA 6010B	1110654	5.0	23	0.996	9/19/2011	9/20/2011	
Lead	EPA 6010B	1110654	5.0	41	0.996	9/19/2011	9/20/2011	
Sample ID: PUI1073-07 (IKMHSR-OFS-306-002-012 - Soil)								
Reporting Units: mg/kg								
Arsenic	EPA 6010B	1110654	5.0	54	0.998	9/19/2011	9/20/2011	
Lead	EPA 6010B	1110654	5.0	81	0.998	9/19/2011	9/20/2011	

BLIND DUPLICATES TO LAB
09/29/12
MS

[Signature] 1/12/12

TestAmerica Phoenix
Erik Aasen
Project Manager

Ecology and Environment - Lakewood
3700 Industry Ave, Suite 102
Lakewood, CA 90712
Attention: Mike Schwennesen

Project ID: T02-09-11-08-0005

Report Number: PUK0002

Sampled: 10/24/11
Received: 10/28/11

TOTAL METALS

Analyte	Method	Batch	Reporting Limit	Sample Result	Dilution Factor	Date Extracted	Date Analyzed	Data Qualifiers
Sample ID: PUK0002-01 (IKMHSR-0FS-133-004-002 - Soil)								
Reporting Units: mg/kg								
Arsenic	EPA 6010B	11K0042	5.0	90	0.997	11/1/2011	11/3/2011	
Lead	EPA 6010B	11K0042	5.0	280	0.997	11/1/2011	11/3/2011	

MA 11/25/12

TestAmerica Phoenix

Erik Aasen
Project Manager

7 of 135

Ecology and Environment - Lakewood
3700 Industry Ave, Suite 102
Lakewood, CA 90712
Attention: Mike Schwennesen

Project ID: T02-09-11-08-0005

Report Number: PUI1385

Sampled: 09/21/11-09/22/11
Received: 09/22/11

TOTAL METALS

Analyte	Method	Batch	Reporting Limit	Sample Result	Dilution Factor	Date Extracted	Date Analyzed	Data Qualifiers
Sample ID: PUI1385-01 (IKMHSR-OFS-148-006-002 - Soil)				Sampled: 09/21/11				
Reporting Units: mg/kg								
Arsenic	EPA 6010B	1110831	5.0	69 J	0.997	9/23/2011	9/23/2011	M2
Lead	EPA 6010B	1110831	5.0	450 J	0.997	9/23/2011	9/23/2011	M3, N1
Sample ID: PUI1385-02 (IKMHSR-OFS-148-010-002 - Soil)				Sampled: 09/21/11				
Reporting Units: mg/kg								
Arsenic	EPA 6010B	1110831	5.0	39 J	0.979	9/23/2011	9/23/2011	BLIND DUPLICATES TO LAB RS 1/12/12
Lead	EPA 6010B	1110831	5.0	310 J	0.979	9/23/2011	9/23/2011	
Sample ID: PUI1385-03 (IKMHSR-OFS-148-007-002 - Soil)				Sampled: 09/21/11				
Reporting Units: mg/kg								
Arsenic	EPA 6010B	1110831	5.0	120 J	0.954	9/23/2011	9/23/2011	
Lead	EPA 6010B	1110831	5.0	420 J	0.954	9/23/2011	9/23/2011	
Sample ID: PUI1385-04 (IKMHSR-OFS-148-008-002 - Soil)				Sampled: 09/21/11				
Reporting Units: mg/kg								
Arsenic	EPA 6010B	1110831	5.0	290 J	0.962	9/23/2011	9/23/2011	
Lead	EPA 6010B	1110831	5.0	1500 J	0.962	9/23/2011	9/23/2011	
Sample ID: PUI1385-05 (IKMHSR-OFS-148-009-002 - Soil)				Sampled: 09/21/11				
Reporting Units: mg/kg								
Arsenic	EPA 6010B	1110831	5.0	93 J	1	9/23/2011	9/23/2011	
Lead	EPA 6010B	1110831	5.0	380 J	1	9/23/2011	9/23/2011	
Sample ID: PUI1385-06 (BA-OFS-103-COMMON-9/22/11 - Soil)				Sampled: 09/22/11				
Reporting Units: mg/kg								
Arsenic	EPA 6010B	1110831	5.0	9.0 J	1	9/23/2011	9/23/2011	
Barium	EPA 6010B	1110831	5.0	110	1	9/23/2011	9/23/2011	
Cadmium	EPA 6010B	1110831	0.50	ND	1	9/23/2011	9/23/2011	
Chromium	EPA 6010B	1110831	2.0	24	1	9/23/2011	9/23/2011	
Lead	EPA 6010B	1110831	5.0	8.2 J	1	9/23/2011	9/23/2011	
Mercury	EPA 7471A	1110809	0.10	ND	1.09	9/22/2011	9/23/2011	
Selenium	EPA 6010B	1110831	5.0	ND	1	9/23/2011	9/23/2011	
Silver	EPA 6010B	1110831	2.5	ND	1	9/23/2011	9/23/2011	

ms 1/12/12

TestAmerica Phoenix

Erik Aasen
Project Manager

7 of 100

The results pertain only to the samples tested in the laboratory. This report shall not be reproduced, except in full, without written permission from TestAmerica.

PUI1385 <Page 2 of 7>

Ecology and Environment - Lakewood
3700 Industry Ave, Suite 102
Lakewood, CA 90712
Attention: Mike Schwennesen

Project ID: T02-09-11-08-0005

Report Number: PUI1385

Sampled: 09/21/11-09/22/11
Received: 09/22/11

TOTAL METALS

Analyte	Method	Batch	Reporting Limit	Sample Result	Dilution Factor	Date Extracted	Date Analyzed	Data Qualifiers
Sample ID: PUI1385-07 (BA-OFS-103-TOP-9/22/11 - Soil)				Sampled: 09/22/11				
Reporting Units: mg/kg								
Arsenic	EPA 6010B	11I0831	5.0	6.8 J	0.993	9/23/2011	9/23/2011	
Barium	EPA 6010B	11I0831	5.0	69	0.993	9/23/2011	9/23/2011	
Cadmium	EPA 6010B	11I0831	0.50	ND	0.993	9/23/2011	9/23/2011	
Chromium	EPA 6010B	11I0831	2.0	17 J	0.993	9/23/2011	9/23/2011	
Lead	EPA 6010B	11I0831	5.0	ND	0.993	9/23/2011	9/23/2011	
Mercury	EPA 7471A	11I0809	0.10	ND	1.03	9/22/2011	9/23/2011	
Selenium	EPA 6010B	11I0831	5.0	ND	0.993	9/23/2011	9/23/2011	
Silver	EPA 6010B	11I0831	2.5	ND	0.993	9/23/2011	9/23/2011	

MA 1/12/12

TestAmerica Phoenix

Erik Aasen
Project Manager

Ecology and Environment - Lakewood
 3700 Industry Ave, Suite 102
 Lakewood, CA 90712
 Attention: Mindy Song

Project ID: T02-09-11-08-0005

Report Number: PUJ0029

Sampled: 10/03/11
 Received: 10/03/11

TOTAL METALS

Analyte	Method	Batch	Reporting Limit	Sample Result	Dilution Factor	Date Extracted	Date Analyzed	Data Qualifiers
Sample ID: PUJ0029-01 (IKMHSR-OFS-244/208-001-002 - Soil)								
Reporting Units: mg/kg								
Arsenic	EPA 6010B	11J0041	5.0	26	1	10/3/2011	10/4/2011	
Lead	EPA 6010B	11J0041	5.0	18	1	10/3/2011	10/4/2011	
Sample ID: PUJ0029-02 (IKMHSR-OFS-244/208-002-002 - Soil)								
Reporting Units: mg/kg								
Arsenic	EPA 6010B	11J0041	5.0	21	1	10/3/2011	10/4/2011	
Lead	EPA 6010B	11J0041	5.0	14	1	10/3/2011	10/4/2011	
Sample ID: PUJ0029-03 (IKMHSR-OFS132-005-002 - Soil)								
Reporting Units: mg/kg								
Arsenic	EPA 6010B	11J0041	5.0	93	1	10/3/2011	10/4/2011	
Lead	EPA 6010B	11J0041	5.0	320	1	10/3/2011	10/4/2011	
Sample ID: PUJ0029-04 (IKMHSR-OFS132-006-002 - Soil)								
Reporting Units: mg/kg								
Arsenic	EPA 6010B	11J0041	5.0	14	1	10/3/2011	10/4/2011	
Lead	EPA 6010B	11J0041	5.0	23	1	10/3/2011	10/4/2011	
Sample ID: PUJ0029-05 (IKMHSR-OFS132-007-002 - Soil)								
Reporting Units: mg/kg								
Arsenic	EPA 6010B	11J0041	5.0	52	1	10/3/2011	10/4/2011	
Lead	EPA 6010B	11J0041	5.0	400	1	10/3/2011	10/4/2011	
Sample ID: PUJ0029-06 (IKMHSR-OFS132-008-002 - Soil)								
Reporting Units: mg/kg								
Arsenic	EPA 6010B	11J0041	5.0	150	1	10/3/2011	10/4/2011	
Lead	EPA 6010B	11J0041	5.0	660	1	10/3/2011	10/4/2011	M3

BLIND
 DUPLICATES
 TO LAB
 MS
 1/29/12

[Signature] 1/20/12

TestAmerica Phoenix
 Erik Aasen
 Project Manager

The results pertain only to the samples tested in the laboratory. This report shall not be reproduced, except in full, without written permission from TestAmerica.

Ecology and Environment - Lakewood
3700 Industry Ave, Suite 102
Lakewood, CA 90712
Attention: Mike Schwennesen

Project ID: TO2-09-11-08-0005

Report Number: PUJ0335

Sampled: 10/05/11-10/06/11
Received: 10/06/11

TOTAL METALS

Analyte	Method	Batch	Reporting Limit	Sample Result	Dilution Factor	Date Extracted	Date Analyzed	Data Qualifiers
Sample ID: PUJ0335-01 (IKMHSR-OFS-260-002-002 - Soil)				Sampled: 10/05/11				
Reporting Units: mg/kg								
Arsenic	EPA 6010B	11J0213	5.0	200	0.999	10/6/2011	10/7/2011	
Lead	EPA 6010B	11J0213	5.0	770	0.999	10/6/2011	10/7/2011	
Sample ID: PUJ0335-02 (IKMHSR-OFS-260-003-002 - Soil)				Sampled: 10/05/11				
Reporting Units: mg/kg								
Arsenic	EPA 6010B	11J0213	5.0	75	0.997	10/6/2011	10/7/2011	
Lead	EPA 6010B	11J0213	5.0	330	0.997	10/6/2011	10/7/2011	
Sample ID: PUJ0335-03 (IKMHSR-OFS-118-001-002 - Soil)				Sampled: 10/06/11				
Reporting Units: mg/kg								
Arsenic	EPA 6010B	11J0213	5.0	95	0.996	10/6/2011	10/7/2011	
Lead	EPA 6010B	11J0213	5.0	310	0.996	10/6/2011	10/7/2011	
Sample ID: PUJ0335-04 (IKMHSR-OFS-118-002-002 - Soil)				Sampled: 10/06/11				
Reporting Units: mg/kg								
Arsenic	EPA 6010B	11J0213	5.0	85	0.996	10/6/2011	10/7/2011	
Lead	EPA 6010B	11J0213	5.0	400	0.996	10/6/2011	10/7/2011	

 1/20/12

TestAmerica Phoenix

Erik Aasen
Project Manager

7 of 158

Ecology and Environment - Lakewood
 3700 Industry Ave, Suite 102
 Lakewood, CA 90712
 Attention: Mindy Song

Project ID: T02-09-11-08-005

Report Number: PUI0034

Sampled: 08/31/11-09/01/11
 Received: 09/01/11

TOTAL METALS

Analyte	Method	Batch	Reporting Limit	Sample Result	Dilution Factor	Date Extracted	Date Analyzed	Data Qualifiers
Sample ID: PUI0034-01 (OFS-260-11-002 - Soil)				Sampled: 08/31/11				
Reporting Units: mg/kg								
Arsenic	EPA 6010B	11I0028	5.0	21	0.998	9/1/2011	9/2/2011	
Lead	EPA 6010B	11I0028	5.0	40	0.998	9/1/2011	9/2/2011	
Sample ID: PUI0034-02 (OFS-260-10-002 - Soil)				Sampled: 08/31/11				
Reporting Units: mg/kg								
Arsenic	EPA 6010B	11I0028	5.0	28	0.998	9/1/2011	9/2/2011	
Lead	EPA 6010B	11I0028	5.0	110	0.998	9/1/2011	9/2/2011	
Sample ID: PUI0034-03 (OFS-260-12-002 - Soil)				Sampled: 08/31/11				
Reporting Units: mg/kg								
Arsenic	EPA 6010B	11I0028	5.0	41	0.997	9/1/2011	9/2/2011	
Lead	EPA 6010B	11I0028	5.0	63	0.997	9/1/2011	9/2/2011	
Sample ID: PUI0034-04 (OFS-260-13-002 - Soil)				Sampled: 08/31/11				
Reporting Units: mg/kg								
Arsenic	EPA 6010B	11I0028	5.0	27	0.996	9/1/2011	9/2/2011	
Lead	EPA 6010B	11I0028	5.0	52	0.996	9/1/2011	9/2/2011	
Sample ID: PUI0034-05 (BA-1-1 - Soil)				Sampled: 08/31/11				
Reporting Units: mg/kg								
Arsenic	EPA 6010B	11I0028	5.0	350	0.999	9/1/2011	9/2/2011	
Barium	EPA 6010B	11I0028	5.0	390	0.999	9/1/2011	9/2/2011	
Cadmium	EPA 6010B	11I0028	0.50	ND	0.999	9/1/2011	9/2/2011	B3
Chromium	EPA 6010B	11I0028	2.0	120	0.999	9/1/2011	9/2/2011	
Lead	EPA 6010B	11I0028	5.0	8.7	0.999	9/1/2011	9/2/2011	
Mercury	EPA 7471A	11I0113	0.10	0.16	1.04	9/6/2011	9/7/2011	
Selenium	EPA 6010B	11I0028	5.0	10	0.999	9/1/2011	9/2/2011	
Silver	EPA 6010B	11I0028	2.5	ND	0.999	9/1/2011	9/2/2011	

NOT PART OF ICMHSR TCRA IS 10/3/11

[Signature]
 11/12/12

TestAmerica Phoenix
 Erik Aasen
 Project Manager

The results pertain only to the samples tested in the laboratory. This report shall not be reproduced, except in full, without written permission from TestAmerica.

Ecology and Environment - Lakewood
3700 Industry Ave, Suite 102
Lakewood, CA 90712
Attention: Mindy Song

Project ID: T02-09-11-08-005

Report Number: PUI0034

Sampled: 08/31/11-09/01/11
Received: 09/01/11

TOTAL METALS

Analyte	Method	Batch	Reporting Limit	Sample Result	Dilution Factor	Date Extracted	Date Analyzed	Data Qualifiers
Sample ID: PUI0034-06 (BA-1-2 - Soil)			Sampled: 08/31/11					
Reporting Units: mg/kg								
Arsenic	EPA 6010B	11I0028	5.0	210	0.998	9/1/2011	9/2/2011	
Barium	EPA 6010B	11I0028	5.0	220	0.998	9/1/2011	9/2/2011	
Cadmium	EPA 6010B	11I0028	0.50	ND	0.998	9/1/2011	9/2/2011	B3
Chromium	EPA 6010B	11I0028	2.0	110	0.998	9/1/2011	9/2/2011	
Lead	EPA 6010B	11I0028	5.0	ND	0.998	9/1/2011	9/2/2011	
Mercury	EPA 7471A	11I0113	0.090	ND	0.898	9/6/2011	9/7/2011	
Selenium	EPA 6010B	11I0028	5.0	5.4	0.998	9/1/2011	9/2/2011	
Silver	EPA 6010B	11I0028	2.5	ND	0.998	9/1/2011	9/2/2011	
Sample ID: PUI0034-07 (BA-2-1 - Soil)			Sampled: 08/31/11					
Reporting Units: mg/kg								
Arsenic	EPA 6010B	11I0028	5.0	30	0.999	9/1/2011	9/2/2011	
Barium	EPA 6010B	11I0028	5.0	37	0.999	9/1/2011	9/2/2011	
Cadmium	EPA 6010B	11I0028	0.50	ND	0.999	9/1/2011	9/2/2011	B3
Chromium	EPA 6010B	11I0028	2.0	33	0.999	9/1/2011	9/2/2011	
Lead	EPA 6010B	11I0028	5.0	ND	0.999	9/1/2011	9/2/2011	
Mercury	EPA 7471A	11I0113	0.10	ND	1.09	9/6/2011	9/7/2011	
Selenium	EPA 6010B	11I0028	5.0	5.0	0.999	9/1/2011	9/2/2011	M1
Silver	EPA 6010B	11I0028	2.5	ND	0.999	9/1/2011	9/2/2011	
Sample ID: PUI0034-08 (BA-2-2 - Soil)			Sampled: 08/31/11					
Reporting Units: mg/kg								
Arsenic	EPA 6010B	11I0028	5.0	43	0.998	9/1/2011	9/2/2011	
Barium	EPA 6010B	11I0028	5.0	63	0.998	9/1/2011	9/2/2011	
Cadmium	EPA 6010B	11I0028	0.50	ND	0.998	9/1/2011	9/2/2011	B3
Chromium	EPA 6010B	11I0028	2.0	120	0.998	9/1/2011	9/2/2011	
Lead	EPA 6010B	11I0028	5.0	ND	0.998	9/1/2011	9/2/2011	
Mercury	EPA 7471A	11I0113	0.10	ND	0.963	9/6/2011	9/7/2011	
Selenium	EPA 6010B	11I0028	5.0	5.0	0.998	9/1/2011	9/2/2011	
Silver	EPA 6010B	11I0028	2.5	ND	0.998	9/1/2011	9/2/2011	

M. A.
11/12/12

TestAmerica Phoenix

Erik Aasen
Project Manager

9 of 180

Ecology and Environment - Lakewood
 3700 Industry Ave, Suite 102
 Lakewood, CA 90712
 Attention: Mindy Song

Project ID: T02-09-11-08-005

Report Number: PUI0034

Sampled: 08/31/11-09/01/11
 Received: 09/01/11

TOTAL METALS

Analyte	Method	Batch	Reporting Limit	Sample Result	Dilution Factor	Date Extracted	Date Analyzed	Data Qualifiers	
Sample ID: PUI0034-09 (BA-3-1 - Soil)				Sampled: 09/01/11					
Reporting Units: mg/kg									
Arsenic	EPA 6010B	11I0028	5.0	8.1	0.999	9/1/2011	9/2/2011		
Barium	EPA 6010B	11I0028	5.0	62	0.999	9/1/2011	9/2/2011		
Cadmium	EPA 6010B	11I0028	0.50	ND	0.999	9/1/2011	9/2/2011	B3	
Chromium	EPA 6010B	11I0028	2.0	18	0.999	9/1/2011	9/2/2011		
Lead	EPA 6010B	11I0028	5.0	5.5	0.999	9/1/2011	9/2/2011		
Mercury	EPA 7471A	11I0113	0.10	ND	0.995	9/6/2011	9/7/2011		
Selenium	EPA 6010B	11I0028	5.0	ND	0.999	9/1/2011	9/2/2011		
Silver	EPA 6010B	11I0028	2.5	ND	0.999	9/1/2011	9/2/2011		
Sample ID: PUI0034-10 (OFS-116-001-002-COMP - Soil)				Sampled: 09/01/11					
Reporting Units: mg/kg									
Arsenic	EPA 6010B	11I0028	5.0	35	0.998	9/1/2011	9/2/2011		
Lead	EPA 6010B	11I0028	5.0	41	0.998	9/1/2011	9/2/2011		
Sample ID: PUI0034-11 (OFS-116-002-002-COMP - Soil)				Sampled: 09/01/11					
Reporting Units: mg/kg									
Arsenic	EPA 6010B	11I0028	5.0	150	0.996	9/1/2011	9/2/2011		
Lead	EPA 6010B	11I0028	5.0	200	0.996	9/1/2011	9/2/2011		
Sample ID: PUI0034-12 (OFS-116-902-002-COMP - Soil)				Sampled: 09/01/11					
Reporting Units: mg/kg									
Arsenic	EPA 6010B	11I0028	5.0	160	0.999	9/1/2011	9/2/2011		
Lead	EPA 6010B	11I0028	5.0	230	0.999	9/1/2011	9/2/2011		
Sample ID: PUI0034-13 (OFS-116-003-002-COMP - Soil)				Sampled: 09/01/11					
Reporting Units: mg/kg									
Arsenic	EPA 6010B	11I0028	5.0	19	0.996	9/1/2011	9/2/2011		
Lead	EPA 6010B	11I0028	5.0	23	0.996	9/1/2011	9/2/2011		

NOT PART OF IKMHSR TCRA
 NS 10/3/11

[Handwritten Signature] 1/12/12

TestAmerica Phoenix
 Erik Aasen
 Project Manager

Ecology and Environment - Lakewood
3700 Industry Ave, Suite 102
Lakewood, CA 90712
Attention: Mike Schwennesen

Project ID: T02-09-11-08-0005

Report Number: PUI1702

Sampled: 09/27/11
Received: 09/28/11

TOTAL METALS

Analyte	Method	Batch	Reporting Limit	Sample Result	Dilution Factor	Date Extracted	Date Analyzed	Data Qualifiers
Sample ID: PUI1702-01 (IKMHSR-OFS-301-002-002 - Soil)								
Reporting Units: mg/kg								
Arsenic	EPA 6010B	1111033	5.0	69	0.999	9/28/2011	9/29/2011	
Lead	EPA 6010B	1111033	5.0	230	0.999	9/28/2011	9/29/2011	
Sample ID: PUI1702-02 (IKMHSR-OFS-103-001-002 - Soil)								
Reporting Units: mg/kg								
Arsenic	EPA 6010B	1111033	5.0	62	0.996	9/28/2011	9/29/2011	
Lead	EPA 6010B	1111033	5.0	180	0.996	9/28/2011	9/29/2011	
Sample ID: PUI1702-03 (IKMHSR-OFS-260-001-002 - Soil)								
Reporting Units: mg/kg								
Arsenic	EPA 6010B	1111033	5.0	220	0.998	9/28/2011	9/29/2011	
Lead	EPA 6010B	1111033	5.0	870	0.998	9/28/2011	9/29/2011	M3

 1/20/12

TestAmerica Phoenix

Erik Aasen
Project Manager

7 of 147

Ecology and Environment - Lakewood
3700 Industry Ave, Suite 102
Lakewood, CA 90712
Attention: Mindy Song

Project ID: T02-09-11-08-0005

Report Number: PUI1573

Sampled: 09/26/11
Received: 09/26/11

TOTAL METALS

Analyte	Method	Batch	Reporting Limit	Sample Result	Dilution Factor	Date Extracted	Date Analyzed	Data Qualifiers
Sample ID: PUI1573-01 (IKMHSR-OFS-301-001-002 - Soil)								
Reporting Units: mg/kg								
Arsenic	EPA 6010B	11I0915	5.0	110	0.998	9/26/2011	9/27/2011	
Lead	EPA 6010B	11I0915	5.0	770	0.998	9/26/2011	9/27/2011	M3
Sample ID: PUI1573-02 (IKMHSR-OFS-111-007-002 - Soil)								
Reporting Units: mg/kg								
Arsenic	EPA 6010B	11I0915	5.0	140	0.997	9/26/2011	9/27/2011	
Lead	EPA 6010B	11I0915	5.0	290	0.997	9/26/2011	9/27/2011	
Sample ID: PUI1573-03 (IKMHSR-OFS-111-008-002 - Soil)								
Reporting Units: mg/kg								
Arsenic	EPA 6010B	11I0915	5.0	160	0.996	9/26/2011	9/27/2011	
Lead	EPA 6010B	11I0915	5.0	570	0.996	9/26/2011	9/27/2011	

m 1/20/12

TestAmerica Phoenix
Erik Aasen
Project Manager

Ecology and Environment - Lakewood
3700 Industry Ave, Suite 102
Lakewood, CA 90712
Attention: Mike Schwennesen

Project ID: T02-09-11-08-0005
Report Number: PUJ0107

Sampled: 10/04/11
Received: 10/04/11

TOTAL METALS

Analyte	Method	Batch	Reporting Limit	Sample Result	Dilution Factor	Date Extracted	Date Analyzed	Data Qualifiers
Sample ID: PUJ0107-01 (Arrowhead-Common-003 - Soil)								
Reporting Units: mg/kg								
Arsenic	EPA 6010B	11J0100	5.0	15	0.996	10/4/2011	10/5/2011	
Lead	EPA 6010B	11J0100	5.0	9.9	0.996	10/4/2011	10/5/2011	
Sample ID: PUJ0107-02 (Arrowhead-Common-004 - Soil)								
Reporting Units: mg/kg								
Arsenic	EPA 6010B	11J0100	5.0	15	0.998	10/4/2011	10/5/2011	
Lead	EPA 6010B	11J0100	5.0	11	0.998	10/4/2011	10/5/2011	
Sample ID: PUJ0107-03 (Arrowhead-Common-005 - Soil)								
Reporting Units: mg/kg								
Arsenic	EPA 6010B	11J0100	5.0	16	0.997	10/4/2011	10/5/2011	
Lead	EPA 6010B	11J0100	5.0	12	0.997	10/4/2011	10/5/2011	
Sample ID: PUJ0107-04 (Arrowhead-Common-006 - Soil)								
Reporting Units: mg/kg								
Arsenic	EPA 6010B	11J0100	5.0	14	0.997	10/4/2011	10/5/2011	
Lead	EPA 6010B	11J0100	5.0	10	0.997	10/4/2011	10/5/2011	



TestAmerica Phoenix
Erik Aasen
Project Manager

7 of 161

Ecology and Environment - Lakewood
 3700 Industry Ave, Suite 102
 Lakewood, CA 90712
 Attention: Mike Schwennesen

Project ID: T02-02-09-11-08-0005

Report Number: PUI0848

Sampled: 09/14/11
 Received: 09/14/11

TOTAL METALS

Analyte	Method	Batch	Reporting Limit	Sample Result	Dilution Factor	Date Extracted	Date Analyzed	Data Qualifiers
Sample ID: PUI0848-01 (BA-2-3 - Soil)								
Reporting Units: mg/kg								
Arsenic	EPA 6010B	11I0488	5.0	37	0.999	9/14/2011	9/15/2011	
Barium	EPA 6010B	11I0488	5.0	54	0.999	9/14/2011	9/15/2011	
Cadmium	EPA 6010B	11I0488	0.50	ND	0.999	9/14/2011	9/15/2011	
Chromium	EPA 6010B	11I0488	2.0	57	0.999	9/14/2011	9/15/2011	
Lead	EPA 6010B	11I0488	5.0	8.3	0.999	9/14/2011	9/15/2011	
Mercury	EPA 7471A	11I0506	0.10	ND	1.05	9/15/2011	9/15/2011	
Selenium	EPA 6010B	11I0488	5.0	6.5	0.999	9/14/2011	9/15/2011	
Silver	EPA 6010B	11I0488	2.5	ND	0.999	9/14/2011	9/15/2011	
Sample ID: PUI0848-02 (BA-2-4 - Soil)								
Reporting Units: mg/kg								
Arsenic	EPA 6010B	11I0488	5.0	17	0.996	9/14/2011	9/15/2011	
Barium	EPA 6010B	11I0488	5.0	77	0.996	9/14/2011	9/15/2011	
Cadmium	EPA 6010B	11I0488	0.50	ND	0.996	9/14/2011	9/15/2011	
Chromium	EPA 6010B	11I0488	2.0	13	0.996	9/14/2011	9/15/2011	
Lead	EPA 6010B	11I0488	5.0	16	0.996	9/14/2011	9/15/2011	
Mercury	EPA 7471A	11I0506	0.10	ND	0.985	9/15/2011	9/15/2011	
Selenium	EPA 6010B	11I0488	5.0	ND	0.996	9/14/2011	9/15/2011	
Silver	EPA 6010B	11I0488	2.5	ND	0.996	9/14/2011	9/15/2011	
Sample ID: PUI0848-03 (BA-2-5 - Soil)								
Reporting Units: mg/kg								
Arsenic	EPA 6010B	11I0488	5.0	17	0.999	9/14/2011	9/15/2011	
Barium	EPA 6010B	11I0488	5.0	73	0.999	9/14/2011	9/15/2011	M1, M2
Cadmium	EPA 6010B	11I0488	0.50	ND	0.999	9/14/2011	9/15/2011	
Chromium	EPA 6010B	11I0488	2.0	15	0.999	9/14/2011	9/15/2011	
Lead	EPA 6010B	11I0488	5.0	16	0.999	9/14/2011	9/15/2011	
Mercury	EPA 7471A	11I0506	0.10	ND	1.07	9/15/2011	9/15/2011	
Selenium	EPA 6010B	11I0488	5.0	ND	0.999	9/14/2011	9/15/2011	
Silver	EPA 6010B	11I0488	2.5	ND	0.999	9/14/2011	9/15/2011	

[Handwritten Signature] 1/12/12

TestAmerica Phoenix

Erik Aasen
 Project Manager

Ecology and Environment - Lakewood
3700 Industry Ave, Suite 102
Lakewood, CA 90712
Attention: Mike Schwennesen

Project ID: T02-02-09-11-08-0005

Report Number: PUI0848

Sampled: 09/14/11

Received: 09/14/11

TOTAL METALS

Analyte	Method	Batch	Reporting Limit	Sample Result	Dilution Factor	Date Extracted	Date Analyzed	Data Qualifiers
Sample ID: PUI0848-04 (BA-7-1 - Soil)								
Reporting Units: mg/kg								
Arsenic	EPA 6010B	11I0488	5.0	ND	0.996	9/14/2011	9/15/2011	
Barium	EPA 6010B	11I0488	5.0	77	0.996	9/14/2011	9/15/2011	
Cadmium	EPA 6010B	11I0488	0.50	ND	0.996	9/14/2011	9/15/2011	
Chromium	EPA 6010B	11I0488	2.0	15	0.996	9/14/2011	9/15/2011	
Lead	EPA 6010B	11I0488	5.0	ND	0.996	9/14/2011	9/15/2011	
Mercury	EPA 7471A	11I0506	0.11	ND	1.12	9/15/2011	9/15/2011	
Selenium	EPA 6010B	11I0488	5.0	ND	0.996	9/14/2011	9/15/2011	
Silver	EPA 6010B	11I0488	2.5	ND	0.996	9/14/2011	9/15/2011	

M. J. 1/12/12

TestAmerica Phoenix

Erik Aasen
Project Manager

8 of 138

Ecology and Environment - Lakewood
 3700 Industry Ave, Suite 102
 Lakewood, CA 90712
 Attention: Mindy Song

Project ID: T02-09-11-08-0005

Report Number: PUI0643

Sampled: 09/12/11
 Received: 09/12/11

TOTAL METALS

Analyte	Method	Batch	Reporting Limit	Sample Result	Dilution Factor	Date Extracted	Date Analyzed	Data Qualifiers
Sample ID: PUI0643-01 (BA-3-2 - Soil)								
Reporting Units: mg/kg								
Arsenic	EPA 6010B	11I0376	5.0	11	0.998	9/12/2011	9/13/2011	
Barium	EPA 6010B	11I0376	5.0	64	0.998	9/12/2011	9/13/2011	
Cadmium	EPA 6010B	11I0376	0.50	ND	0.998	9/12/2011	9/13/2011	
Chromium	EPA 6010B	11I0376	2.0	14	0.998	9/12/2011	9/13/2011	
Lead	EPA 6010B	11I0376	5.0	5.4	0.998	9/12/2011	9/13/2011	
Mercury	EPA 7471A	11I0417	0.10	ND	0.989	9/13/2011	9/13/2011	M2
Selenium	EPA 6010B	11I0376	5.0	ND	0.998	9/12/2011	9/13/2011	
Silver	EPA 6010B	11I0376	2.5	ND	0.998	9/12/2011	9/13/2011	
Sample ID: PUI0643-02 (BA-3-3 - Soil)								
Reporting Units: mg/kg								
Arsenic	EPA 6010B	11I0376	5.0	8.2	0.996	9/12/2011	9/13/2011	
Barium	EPA 6010B	11I0376	5.0	73	0.996	9/12/2011	9/13/2011	
Cadmium	EPA 6010B	11I0376	0.50	ND	0.996	9/12/2011	9/13/2011	
Chromium	EPA 6010B	11I0376	2.0	16	0.996	9/12/2011	9/13/2011	
Lead	EPA 6010B	11I0376	5.0	5.7	0.996	9/12/2011	9/13/2011	
Mercury	EPA 7471A	11I0417	0.10	ND	0.991	9/13/2011	9/13/2011	
Selenium	EPA 6010B	11I0376	5.0	ND	0.996	9/12/2011	9/13/2011	
Silver	EPA 6010B	11I0376	2.5	ND	0.996	9/12/2011	9/13/2011	
Sample ID: PUI0643-03 (BA-6-1 - Soil)								
Reporting Units: mg/kg								
Arsenic	EPA 6010B	11I0376	5.0	11	0.999	9/12/2011	9/13/2011	
Barium	EPA 6010B	11I0376	5.0	73	0.999	9/12/2011	9/13/2011	
Cadmium	EPA 6010B	11I0376	0.50	ND	0.999	9/12/2011	9/13/2011	
Chromium	EPA 6010B	11I0376	2.0	4.0	0.999	9/12/2011	9/13/2011	
Lead	EPA 6010B	11I0376	5.0	8.6	0.999	9/12/2011	9/13/2011	
Mercury	EPA 7471A	11I0417	0.10	ND	1.11	9/13/2011	9/13/2011	
Selenium	EPA 6010B	11I0376	5.0	ND	0.999	9/12/2011	9/13/2011	
Silver	EPA 6010B	11I0376	2.5	ND	0.999	9/12/2011	9/13/2011	

Mindy Song 11/12/12

TestAmerica Phoenix

Erik Aasen
 Project Manager

7 of 167

Ecology and Environment - Lakewood
3700 Industry Ave, Suite 102
Lakewood, CA 90712
Attention: Mindy Song

Project ID: T02-09-1L-08-0005 Iron King Mine-Humboldt Smelter
Report Number: PUI0617

Sampled: 09/12/11
Received: 09/12/11

TOTAL METALS

Analyte	Method	Batch	Reporting Limit	Sample Result	Dilution Factor	Date Extracted	Date Analyzed	Data Qualifiers
Sample ID: PUI0617-01 (BA-4-1 - Soil)								
Reporting Units: mg/kg								
Arsenic	EPA 6010B	11I0376	5.0	ND	0.998	9/12/2011	9/13/2011	
Barium	EPA 6010B	11I0376	5.0	77	0.998	9/12/2011	9/13/2011	
Cadmium	EPA 6010B	11I0376	0.50	ND	0.998	9/12/2011	9/13/2011	
Chromium	EPA 6010B	11I0376	2.0	7.4	0.998	9/12/2011	9/13/2011	
Lead	EPA 6010B	11I0376	5.0	6.1	0.998	9/12/2011	9/13/2011	
Mercury	EPA 7471A	11I0364	0.10	ND	0.919	9/12/2011	9/13/2011	
Selenium	EPA 6010B	11I0376	5.0	ND	0.998	9/12/2011	9/13/2011	
Silver	EPA 6010B	11I0376	2.5	ND	0.998	9/12/2011	9/13/2011	
Sample ID: PUI0617-02 (BA-4-2 - Soil)								
Reporting Units: mg/kg								
Arsenic	EPA 6010B	11I0376	5.0	ND	0.999	9/12/2011	9/13/2011	
Barium	EPA 6010B	11I0376	5.0	93	0.999	9/12/2011	9/13/2011	
Cadmium	EPA 6010B	11I0376	0.50	ND	0.999	9/12/2011	9/13/2011	
Chromium	EPA 6010B	11I0376	2.0	8.7	0.999	9/12/2011	9/13/2011	
Lead	EPA 6010B	11I0376	5.0	7.1	0.999	9/12/2011	9/13/2011	
Mercury	EPA 7471A	11I0364	0.10	ND	0.994	9/12/2011	9/13/2011	M2
Selenium	EPA 6010B	11I0376	5.0	ND	0.999	9/12/2011	9/13/2011	
Silver	EPA 6010B	11I0376	2.5	ND	0.999	9/12/2011	9/13/2011	
Sample ID: PUI0617-03 (BA-5-1 - Soil)								
Reporting Units: mg/kg								
Arsenic	EPA 6010B	11I0376	5.0	7.4	0.997	9/12/2011	9/13/2011	
Barium	EPA 6010B	11I0376	5.0	80	0.997	9/12/2011	9/13/2011	
Cadmium	EPA 6010B	11I0376	0.50	ND	0.997	9/12/2011	9/13/2011	
Chromium	EPA 6010B	11I0376	2.0	15	0.997	9/12/2011	9/13/2011	
Lead	EPA 6010B	11I0376	5.0	5.9	0.997	9/12/2011	9/13/2011	
Mercury	EPA 7471A	11I0364	0.11	ND	1.14	9/12/2011	9/13/2011	
Selenium	EPA 6010B	11I0376	5.0	ND	0.997	9/12/2011	9/13/2011	
Silver	EPA 6010B	11I0376	2.5	ND	0.997	9/12/2011	9/13/2011	

M. A. 1/12/12

TestAmerica Phoenix

Erik Aasen
Project Manager

7 of 149

Ecology and Environment - Lakewood
3700 Industry Ave, Suite 102
Lakewood, CA 90712
Attention: Mindy Song

Project ID: T02-09-1L-08-0005 Iron King Mine-Humboldt Smelter

Report Number: PUI0617

Sampled: 09/12/11
Received: 09/12/11

TOTAL METALS

Analyte	Method	Batch	Reporting Limit	Sample Result	Dilution Factor	Date Extracted	Date Analyzed	Data Qualifiers
Sample ID: PUI0617-04 (BA-5-2 - Soil)								
Reporting Units: mg/kg								
Arsenic	EPA 6010B	11I0376	5.0	7.3	1	9/12/2011	9/13/2011	
Barium	EPA 6010B	11I0376	5.0	90	1	9/12/2011	9/13/2011	
Cadmium	EPA 6010B	11I0376	0.50	ND	1	9/12/2011	9/13/2011	
Chromium	EPA 6010B	11I0376	2.0	16	1	9/12/2011	9/13/2011	
Lead	EPA 6010B	11I0376	5.0	5.8	1	9/12/2011	9/13/2011	
Mercury	EPA 7471A	11I0364	0.091	ND	0.906	9/12/2011	9/13/2011	
Selenium	EPA 6010B	11I0376	5.0	ND	1	9/12/2011	9/13/2011	
Silver	EPA 6010B	11I0376	2.5	ND	1	9/12/2011	9/13/2011	

Mindy Song 11/12/12

TestAmerica Phoenix

Erik Aasen
Project Manager

8 of 149

Ecology and Environment - Lakewood
 3700 Industry Ave, Suite 102
 Lakewood, CA 90712
 Attention: Mike Schwennesen

Project ID: T02-09-11-08-0005 Iron King Mine-Humboldt Smelter
 Report Number: PUI1047

Sampled: 09/16/11
 Received: 09/16/11

TOTAL METALS

Analyte	Method	Batch	Reporting Limit	Sample Result	Dilution Factor	Date Extracted	Date Analyzed	Data Qualifiers
Sample ID: PUI1047-01 (BA-7-2 - Soil)								
Reporting Units: mg/kg								
Arsenic	EPA 6010B	11I0581	5.0	5.1	0.998	9/16/2011	9/18/2011	
Barium	EPA 6010B	11I0581	5.0	81	0.998	9/16/2011	9/18/2011	
Cadmium	EPA 6010B	11I0581	0.50	ND	0.998	9/16/2011	9/18/2011	
Chromium	EPA 6010B	11I0581	2.0	18	0.998	9/16/2011	9/18/2011	
Lead	EPA 6010B	11I0581	5.0	ND	0.998	9/16/2011	9/18/2011	
Mercury	EPA 7471A	11I0619	0.10	ND	0.925	9/19/2011	9/19/2011	
Selenium	EPA 6010B	11I0581	5.0	ND	0.998	9/16/2011	9/18/2011	
Silver	EPA 6010B	11I0581	2.5	ND	0.998	9/16/2011	9/18/2011	
Sample ID: PUI1047-02 (BA-7-3 - Soil)								
Reporting Units: mg/kg								
Arsenic	EPA 6010B	11I0581	5.0	ND	0.998	9/16/2011	9/18/2011	
Barium	EPA 6010B	11I0581	5.0	70	0.998	9/16/2011	9/18/2011	
Cadmium	EPA 6010B	11I0581	0.50	ND	0.998	9/16/2011	9/18/2011	
Chromium	EPA 6010B	11I0581	2.0	18	0.998	9/16/2011	9/18/2011	
Lead	EPA 6010B	11I0581	5.0	ND	0.998	9/16/2011	9/18/2011	
Mercury	EPA 7471A	11I0619	0.10	ND	1.01	9/19/2011	9/19/2011	
Selenium	EPA 6010B	11I0581	5.0	ND	0.998	9/16/2011	9/18/2011	
Silver	EPA 6010B	11I0581	2.5	ND	0.998	9/16/2011	9/18/2011	
Sample ID: PUI1047-03 (IKMHSR-OFS-148-004-002 - Soil)								
Reporting Units: mg/kg								
Arsenic	EPA 6010B	11I0581	5.0	120	0.999	9/16/2011	9/18/2011	
Lead	EPA 6010B	11I0581	5.0	470	0.999	9/16/2011	9/18/2011	

 1/12/12

TestAmerica Phoenix
 Erik Aasen
 Project Manager

7 of 136

Ecology and Environment - Lakewood 3700 Industry Ave, Suite 102 Lakewood, CA 90712 Attention: Mike Schwennesen	Project ID: T02-09-11-08-0005 Report Number: PUK0352	Sampled: 11/03/11 Received: 11/04/11
---	---	---

TOTAL METALS

Analyte	Method	Batch	Reporting Limit	Sample Result	Dilution Factor	Date Extracted	Date Analyzed	Data Qualifiers
Sample ID: PUK0352-01 (IKMHSR-OFS-002-010-002 - Soil)								
Reporting Units: mg/kg								
Arsenic	EPA 6010B	11K0189	5.0	21	0.998	11/4/2011	11/5/2011	
Lead	EPA 6010B	11K0189	5.0	6.1	0.998	11/4/2011	11/5/2011	
Sample ID: PUK0352-02 (IKMHSR-OFS-002-011-002 - Soil)								
Reporting Units: mg/kg								
Arsenic	EPA 6010B	11K0189	5.0	18	0.997	11/4/2011	11/5/2011	
Lead	EPA 6010B	11K0189	5.0	ND	0.997	11/4/2011	11/5/2011	
Sample ID: PUK0352-03 (IKMHSR-OFS-002-012-120 - Soil)								
Reporting Units: mg/kg								
Arsenic	EPA 6010B	11K0189	5.0	190	0.998	11/4/2011	11/5/2011	
Lead	EPA 6010B	11K0189	5.0	31	0.998	11/4/2011	11/5/2011	
Sample ID: PUK0352-04 (IKMHSR-OFS-002-013-002 - Soil)								
Reporting Units: mg/kg								
Arsenic	EPA 6010B	11K0189	5.0	43	0.999	11/4/2011	11/5/2011	
Lead	EPA 6010B	11K0189	5.0	25	0.999	11/4/2011	11/5/2011	

[Handwritten Signature] 1/25/12

TestAmerica Phoenix

Erik Aasen
Project Manager

7 of 161

The results pertain only to the samples tested in the laboratory. This report shall not be reproduced, except in full, without written permission from TestAmerica.

PUK0352 <Page 2 of 5>

Ecology and Environment - Lakewood
3700 Industry Ave, Suite 102
Lakewood, CA 90712
Attention: Mike Schwennesen

Project ID: T02-09-11-08-0005

Report Number: PUI1808

Sampled: 09/28/11-09/29/11
Received: 09/29/11

TOTAL METALS

Analyte	Method	Batch	Reporting Limit	Sample Result	Dilution Factor	Date Extracted	Date Analyzed	Data Qualifiers
Sample ID: PUI1808-01 (Arrowhead-Common-001 - Soil)				Sampled: 09/29/11				
Reporting Units: mg/kg								
Arsenic	EPA 6010B	11I1086	5.0	14	0.996	9/29/2011	9/30/2011	
Lead	EPA 6010B	11I1086	5.0	8.8	0.996	9/29/2011	9/30/2011	
Sample ID: PUI1808-02 (Arrowhead-Common-002 - Soil)				Sampled: 09/29/11				
Reporting Units: mg/kg								
Arsenic	EPA 6010B	11I1086	5.0	13	0.996	9/29/2011	9/30/2011	
Lead	EPA 6010B	11I1086	5.0	8.8	0.996	9/29/2011	9/30/2011	
Sample ID: PUI1808-03 (MDI-GD-Common-001 - Soil)				Sampled: 09/28/11				
Reporting Units: mg/kg								
Arsenic	EPA 6010B	11I1086	5.0	8.9	0.995	9/29/2011	9/30/2011	
Lead	EPA 6010B	11I1086	5.0	ND	0.995	9/29/2011	9/30/2011	
Sample ID: PUI1808-04 (MDI-GD-Common-002 - Soil)				Sampled: 09/28/11				
Reporting Units: mg/kg								
Arsenic	EPA 6010B	11I1086	5.0	8.3	0.998	9/29/2011	9/30/2011	
Lead	EPA 6010B	11I1086	5.0	5.7	0.998	9/29/2011	9/30/2011	
Sample ID: PUI1808-05 (NCLS-Topsoil-001 - Soil)				Sampled: 09/29/11				
Reporting Units: mg/kg								
Arsenic	EPA 6010B	11I1086	5.0	ND	0.998	9/29/2011	9/30/2011	
Lead	EPA 6010B	11I1086	5.0	ND	0.998	9/29/2011	9/30/2011	

[Handwritten Signature] 1/20/12

TestAmerica Phoenix

Erik Aasen
Project Manager

7 of 157

Ecology and Environment - Lakewood
 3700 Industry Ave, Suite 102
 Lakewood, CA 90712
 Attention: Mike Schwennesen

Project ID: T02-09-11-08-0005

Report Number: PUI1474

Sampled: 09/23/11
 Received: 09/23/11

TOTAL METALS

Analyte	Method	Batch	Reporting Limit	Sample Result	Dilution Factor	Date Extracted	Date Analyzed	Data Qualifiers
Sample ID: PUI1474-01 (MDI-GLENDALE-TOPSOILA - Soil)								
Reporting Units: mg/kg								
Arsenic	EPA 6010B	11I0855	5.0	9.0	0.995	9/23/2011	9/26/2011	
Barium	EPA 6010B	11I0855	5.0	100 J	0.995	9/23/2011	9/26/2011	M2
Cadmium	EPA 6010B	11I0855	0.50	ND	0.995	9/23/2011	9/26/2011	
Chromium	EPA 6010B	11I0855	2.0	23	0.995	9/23/2011	9/26/2011	
Lead	EPA 6010B	11I0855	5.0	5.8	0.995	9/23/2011	9/26/2011	
Mercury	EPA 7471A	11I0900	0.10	ND	0.933	9/26/2011	9/26/2011	
Selenium	EPA 6010B	11I0855	5.0	ND	0.995	9/23/2011	9/26/2011	
Silver	EPA 6010B	11I0855	2.5	ND	0.995	9/23/2011	9/26/2011	
Sample ID: PUI1474-02 (MDI-GLENDALE-TOPSOILB - Soil)								
Reporting Units: mg/kg								
Arsenic	EPA 6010B	11I0855	5.0	11	0.998	9/23/2011	9/26/2011	
Barium	EPA 6010B	11I0855	5.0	110 J	0.998	9/23/2011	9/26/2011	
Cadmium	EPA 6010B	11I0855	0.50	ND	0.998	9/23/2011	9/26/2011	
Chromium	EPA 6010B	11I0855	2.0	25	0.998	9/23/2011	9/26/2011	
Lead	EPA 6010B	11I0855	5.0	6.4	0.998	9/23/2011	9/26/2011	
Mercury	EPA 7471A	11I0900	0.10	ND	0.915	9/26/2011	9/26/2011	
Selenium	EPA 6010B	11I0855	5.0	ND	0.998	9/23/2011	9/26/2011	
Silver	EPA 6010B	11I0855	2.5	ND	0.998	9/23/2011	9/26/2011	
Sample ID: PUI1474-03 (MDI-RG-COMMON - Soil)								
Reporting Units: mg/kg								
Arsenic	EPA 6010B	11I0855	5.0	10	0.999	9/23/2011	9/26/2011	
Barium	EPA 6010B	11I0855	5.0	120 J	0.999	9/23/2011	9/26/2011	
Cadmium	EPA 6010B	11I0855	0.50	ND	0.999	9/23/2011	9/26/2011	
Chromium	EPA 6010B	11I0855	2.0	25	0.999	9/23/2011	9/26/2011	
Lead	EPA 6010B	11I0855	5.0	9.1	0.999	9/23/2011	9/26/2011	
Mercury	EPA 7471A	11I0900	0.10	ND	0.978	9/26/2011	9/26/2011	
Selenium	EPA 6010B	11I0855	5.0	ND	0.999	9/23/2011	9/26/2011	
Silver	EPA 6010B	11I0855	2.5	ND	0.999	9/23/2011	9/26/2011	

[Handwritten Signature] 1/20/12

TestAmerica Phoenix

Erik Aasen
 Project Manager

Ecology and Environment - Lakewood
3700 Industry Ave, Suite 102
Lakewood, CA 90712
Attention: Mike Schwennesen

Project ID: T02-09-11-08-0005

Report Number: PUI1474

Sampled: 09/23/11
Received: 09/23/11

TOTAL METALS

Analyte	Method	Batch	Reporting Limit	Sample Result	Dilution Factor	Date Extracted	Date Analyzed	Data Qualifiers
Sample ID: PUI1474-04 (MDI-MG-TOPSOIL - Soil)								
Reporting Units: mg/kg								
Arsenic	EPA 6010B	11I0855	5.0	ND	0.996	9/23/2011	9/26/2011	
Barium	EPA 6010B	11I0855	5.0	87 J	0.996	9/23/2011	9/26/2011	
Cadmium	EPA 6010B	11I0855	0.50	ND	0.996	9/23/2011	9/26/2011	
Chromium	EPA 6010B	11I0855	2.0	12	0.996	9/23/2011	9/26/2011	
Lead	EPA 6010B	11I0855	5.0	8.4	0.996	9/23/2011	9/26/2011	
Mercury	EPA 7471A	11I0900	0.10	ND	1.02	9/26/2011	9/26/2011	
Selenium	EPA 6010B	11I0855	5.0	ND	0.996	9/23/2011	9/26/2011	
Silver	EPA 6010B	11I0855	2.5	ND	0.996	9/23/2011	9/26/2011	

TestAmerica Phoenix

Erik Vaasen
Project Manager

8 of 167

Ecology and Environment - Lakewood
3700 Industry Ave, Suite 102
Lakewood, CA 90712
Attention: Mike Schwennesen

Project ID: T02-09-11-08-0005

Report Number: PUK0099

Sampled: 11/01/11
Received: 11/02/11

TOTAL METALS

Analyte	Method	Batch	Reporting Limit	Sample Result	Dilution Factor	Date Extracted	Date Analyzed	Data Qualifiers
Sample ID: PUK0099-01RE1 (IKMHSR-OFS-002-006-002 - Soil)								
Reporting Units: mg/kg								
Arsenic	EPA 6010B	11K0255	5.0	42	0.998	11/7/2011	11/9/2011	
Lead	EPA 6010B	11K0255	5.0	42	0.998	11/7/2011	11/9/2011	
Sample ID: PUK0099-02RE1 (IKMHSR-OFS-002-007-002 - Soil)								
Reporting Units: mg/kg								
Arsenic	EPA 6010B	11K0255	5.0	110	0.996	11/7/2011	11/9/2011	
Lead	EPA 6010B	11K0255	5.0	71	0.996	11/7/2011	11/9/2011	
Sample ID: PUK0099-03RE1 (IKMHSR-OFS-002-008-060 - Soil)								
Reporting Units: mg/kg								
Arsenic	EPA 6010B	11K0255	5.0	86	0.998	11/7/2011	11/9/2011	
Lead	EPA 6010B	11K0255	5.0	85	0.998	11/7/2011	11/9/2011	
Sample ID: PUK0099-04RE1 (IKMHSR-OFS-002-009-060 - Soil)								
Reporting Units: mg/kg								
Arsenic	EPA 6010B	11K0255	5.0	1300	0.997	11/7/2011	11/9/2011	
Lead	EPA 6010B	11K0255	5.0	2000	0.997	11/7/2011	11/9/2011	

 11/25/12

TestAmerica Phoenix

Erik Vaasen
Project Manager

7 of 127

The results pertain only to the samples tested in the laboratory. This report shall not be reproduced, except in full, without written permission from TestAmerica.

PUK0099 <Page 2 of 5>

Ecology and Environment - Lakewood
3700 Industry Ave, Suite 102
Lakewood, CA 90712
Mindy Song

Work Order: PUI1583
Project: Iron King Mine - Humboldt Smelter Removal
Project Number: T02-09-11-08-0005

Received: 09/27/11
Reported: 09/28/11 17:01

ANALYTICAL REPORT

Analyte	Result	Qual	Date Analyzed	Analyst	Rpt Limit ug, Total	Method
Metals using ICP-AES by NIOSH 7300 (Modified)						
Sample ID: PUI1583-01 (IKMHSR-9/22/11-Air-1)		Filter	Sample Air Volume: 1056L		Sampled: 09/22/11	
	ug, Total	mg/m3	ppm		Prepared: 09/27/11 18:32	
Arsenic	<2.50	<0.00237	<0.000773	9/28/2011	bb	2.50 NIOSH 7300
Lead	<0.312	<0.000295	<0.0000349	9/28/2011	bb	0.312 NIOSH 7300
Sample ID: PUI1583-02 (IKMHSR-9/22/11-Air-2)		Filter	Sample Air Volume: 1045L		Sampled: 09/22/11	
	ug, Total	mg/m3	ppm		Prepared: 09/27/11 18:32	
Arsenic	<2.50	<0.00239	<0.000781	9/28/2011	bb	2.50 NIOSH 7300
Lead	<0.312	<0.000299	<0.0000352	9/28/2011	bb	0.312 NIOSH 7300
Sample ID: PUI1583-03 (IKMHSR-9/22/11-Air-3)		Filter	Sample Air Volume: 1056L		Sampled: 09/22/11	
	ug, Total	mg/m3	ppm		Prepared: 09/27/11 18:32	
Arsenic	<2.50	<0.00237	<0.000773	9/28/2011	bb	2.50 NIOSH 7300
Lead	<0.312	<0.000295	<0.0000349	9/28/2011	bb	0.312 NIOSH 7300
Sample ID: PUI1583-04 (IKMHSR-9/22/11-Air-FB)		Filter	Sample Air Volume: L		Sampled: 09/22/11	
	ug, Total	mg/m3	ppm		Prepared: 09/27/11 18:32	
Arsenic	<2.50	--	--	9/28/2011	bb	2.50 NIOSH 7300
Lead	<0.312	--	--	9/28/2011	bb	0.312 NIOSH 7300

M. Song 11/10/12

Ecology and Environment - Lakewood
 3700 Industry Ave, Suite 102
 Lakewood, CA 90712
 Mike Schwennesen

Work Order: PUJ1805
 Project: Iron King Mine - Humboldt Smelter Removal
 Project Number: T02-09-11-08-0005

Received: 10/28/11
 Reported: 11/04/11 14:49

ANALYTICAL REPORT

Analyte	Result	Qual	Date Analyzed	Analyst	Rpt Limit ug, Total	Method
Metals using ICP-AES by NIOSH 7300 (Modified)						
Sample ID: PUJ1805-01 (1 KMHSR-10/10/11-AIR-1)		Filter		Sample Air Volume: 1165L		Sampled: 10/10/11 08:00
	ug, Total	mg/m3	ppm			Prepared: 11/02/11 19:20
Arsenic	<2.50	<0.00215	<0.000700	11/3/2011	bb	2.50 NIOSH 7300
Lead	0.521	0.000447	0.0000528	11/3/2011	bb	0.312 NIOSH 7300
Sample ID: PUJ1805-02 (1 KMHSR-10/10/11-AIR-2)		Filter		Sample Air Volume: 1109L		Sampled: 10/10/11 08:00
	ug, Total	mg/m3	ppm			Prepared: 11/02/11 19:20
Arsenic	<2.50	<0.00225	<0.000736	11/3/2011	bb	2.50 NIOSH 7300
Lead	<0.312	<0.000281	<0.0000332	11/3/2011	bb	0.312 NIOSH 7300
Sample ID: PUJ1805-03 (1 KMHSR-10/10/11-AIR-3)		Filter		Sample Air Volume: 1112L		Sampled: 10/10/11 08:00
	ug, Total	mg/m3	ppm			Prepared: 11/02/11 19:20
Arsenic	<2.50	<0.00225	<0.000734	11/3/2011	bb	2.50 NIOSH 7300
Lead	<0.312	<0.000281	<0.0000331	11/3/2011	bb	0.312 NIOSH 7300
Sample ID: PUJ1805-04 (1 KMHSR-10/10/11-AIR-4)		Filter		Sample Air Volume: 1106L		Sampled: 10/10/11 08:00
	ug, Total	mg/m3	ppm			Prepared: 11/02/11 19:20
Arsenic	<2.50	<0.00226	<0.000738	11/3/2011	bb	2.50 NIOSH 7300
Lead	<0.312	<0.000282	<0.0000333	11/3/2011	bb	0.312 NIOSH 7300
Sample ID: PUJ1805-05 (1 KMHSR-10/10/11-AIR-FB)		Filter		Sample Air Volume: L		Sampled: 10/10/11 08:00
	ug, Total	mg/m3	ppm			Prepared: 11/02/11 19:20
Arsenic	<2.50	--	--	11/3/2011	bb	2.50 NIOSH 7300
Lead	<0.312	--	--	11/3/2011	bb	0.312 NIOSH 7300

MA 11/10/12

Ecology and Environment - Lakewood 3700 Industry Ave, Suite 102 Lakewood, CA 90712 Mike Schwennesen	Work Order: PUK0100 Project: Iron King Mine - Humboldt Smelter Removal Project Number: T02-09-11-08-0005	Received: 11/02/11 Reported: 11/09/11 17:13
--	--	--

ANALYTICAL REPORT

Analyte	Result	Qual	Date Analyzed	Analyst	Rpt Limit ug, Total	Method
Metals using ICP-AES by NIOSH 7300 (Modified)						
Sample ID: PUK0100-01 (IKMHSR-10/31/11-Air-1)		Filter	Sample Air Volume: 1294L		Sampled: 11/01/11	
	ug, Total	mg/m3	ppm		Prepared: 11/02/11 19:20	
Arsenic	<2.50	<0.00193	<0.000630	11/3/2011	bb	2.50 NIOSH 7300
Lead	<0.312	<0.000241	<0.0000285	11/3/2011	bb	0.312 NIOSH 7300
Sample ID: PUK0100-02 (IKMHSR-10/31/11-Air-2)		Filter	Sample Air Volume: 1234L		Sampled: 11/01/11	
	ug, Total	mg/m3	ppm		Prepared: 11/02/11 19:20	
Arsenic	<2.50	<0.00203	<0.000661	11/3/2011	bb	2.50 NIOSH 7300
Lead	<0.312	<0.000253	<0.0000298	11/3/2011	bb	0.312 NIOSH 7300
Sample ID: PUK0100-03 (IKMHSR-10/31/11-Air-3)		Filter	Sample Air Volume: 1313L		Sampled: 11/01/11	
	ug, Total	mg/m3	ppm		Prepared: 11/02/11 19:20	
Arsenic	<2.50	<0.00190	<0.000621	11/3/2011	bb	2.50 NIOSH 7300
Lead	<0.312	<0.000238	<0.0000280	11/3/2011	bb	0.312 NIOSH 7300
Sample ID: PUK0100-04 (IKMHSR-10/31/11-Air-FB)		Filter	Sample Air Volume: L		Sampled: 11/01/11	
	ug, Total	mg/m3	ppm		Prepared: 11/02/11 19:20	
Arsenic	<2.50	--	--	11/8/2011	MDD	2.50 NIOSH 7300
Lead	<0.312	--	--	11/8/2011	MDD	0.312 NIOSH 7300

[Handwritten Signature] 11/10/12

Ecology and Environment - Lakewood 3700 Industry Ave, Suite 102 Lakewood, CA 90712 Mike Schwennesen	Work Order: PUK0709 Project: Iron King Mine - Humboldt Smelter Removal Project Number: T02-09-11-08-0005	Received: 11/09/11 Reported: 11/17/11 08:58
--	--	--

ANALYTICAL REPORT

Analyte	Result	Qual	Date Analyzed	Analyst	Rpt Limit ug, Total	Method
Metals using ICP-AES by NIOSH 7300 (Modified)						
Sample ID: PUK0709-01 (IKMHSR-11/8/11-AIR-1)		Filter	Sample Air Volume: 1281L		Sampled: 11/08/11	
	ug, Total	mg/m3	ppm		Prepared: 11/14/11 18:50	
Arsenic	<2.50	<0.00195	<0.000637	11/15/2011	bb	2.50 NIOSH 7300
Lead	<0.312	<0.000244	<0.0000287	11/16/2011	MDD	0.312 NIOSH 7300
Sample ID: PUK0709-02 (IKMHSR-11/8/11-AIR-2)		Filter	Sample Air Volume: 1212L		Sampled: 11/08/11	
	ug, Total	mg/m3	ppm		Prepared: 11/14/11 18:50	
Arsenic	<2.50	<0.00206	<0.000673	11/15/2011	bb	2.50 NIOSH 7300
Lead	<0.312	<0.000257	<0.0000304	11/16/2011	MDD	0.312 NIOSH 7300
Sample ID: PUK0709-03 (IKMHSR-11/8/11-AIR-3)		Filter	Sample Air Volume: 1283L		Sampled: 11/08/11	
	ug, Total	mg/m3	ppm		Prepared: 11/14/11 18:50	
Arsenic	<2.50	<0.00195	<0.000636	11/15/2011	bb	2.50 NIOSH 7300
Lead	<0.312	<0.000243	<0.0000287	11/16/2011	MDD	0.312 NIOSH 7300
Sample ID: PUK0709-04 (IKMHSR-11/8/11-AIR-FB)		Filter	Sample Air Volume: L		Sampled: 11/08/11	
	ug, Total	mg/m3	ppm		Prepared: 11/14/11 18:50	
Arsenic	<2.50	--	--	11/15/2011	bb	2.50 NIOSH 7300
Lead	<0.312	--	--	11/16/2011	MDD	0.312 NIOSH 7300

msj 11/10/12



ecology and environment, inc.

International Specialists in the Environment

3700 Industry Avenue, Suite 102
Lakewood, California 90712

October 26, 2011

MEMORANDUM

SUBJECT: Import Material Delivery and Sampling for the Iron King Mine – Humboldt Smelter Time-Critical Removal Action

FROM: Christopher Myers, START
Ecology and Environment, Inc.

TO: Craig Benson, Federal On-Scene Coordinator
US EPA Region 9 Emergency Response Section

During removal activities at the Iron King Mine – Humboldt Smelter site, Ecology and Environment, Inc.'s Superfund Technical Assessment and Response Team (START) was directed by the United States Environmental Protection Agency (U.S. EPA) to collect samples of borrow material from local suppliers in the area of the Iron King Mine – Humboldt Smelter Removal site (the Site). The samples were necessary to determine which material would be suitable to replace contaminated soil removed from residential properties at the Site as part of a time-critical removal action (TCRA).

The contaminants of concern at the Site are arsenic and lead in soil. The site-specific action levels for these contaminants are 38 milligrams per kilogram (mg/kg) for arsenic, and 23 mg/kg for lead. Concentrations of arsenic and lead in borrow material must be at or below these concentrations. The type of soil needed to replace the removed contaminated soil is referred to as “one-inch minus” because it is run through a screen with one-inch mesh.

The START collected samples of the material to initially characterize the material and collected additional samples periodically as it was imported to the Site.

Over the period August 31 through October 13, 2011 the START collected composite samples of the borrow material from each of the sources, and had the samples analyzed by TestAmerica Laboratory in Phoenix, Arizona. The requested analytes and analytical methods were Resource Conservation and Recovery Act (RCRA) metals by U.S. EPA Methods 6010B/7471A. The volumes of material from the suppliers and the results for the arsenic and lead analytes are presented below. Note that the results only represent a “snapshot” of the material available on the date sampled, and that the results are based on a single composite sample. Sampling of backfill material was an ongoing process and was performed as needed to stay ahead of the import events. The following tables provide all relevant information for borrow material delivery and sampling through the close of the project.

Common Soil				
Date	Origin	Load Count	Weight (tons)	Total Import (tons)
09/22/11	MDI Rock Rose Garden	1	23.79	23.79
09/22/11	MDI Rock Paradise Valley	1	23.44	47.23
09/22/11	MDI Rock Rose Garden	1	24.45	71.68
09/22/11	MDI Rock Rose Garden	1	22.91	94.59
09/22/11	MDI Rock Rose Garden	1	24.37	118.96
09/22/11	MDI Rock Paradise Valley	1	22.80	141.76
09/22/11	MDI Rock Rose Garden	1	23.36	165.12
09/22/11	MDI Rock Paradise Valley	1	32.32	197.44
09/28/11	MDI Rock Paradise Valley	1	23.61	221.05
09/28/11	MDI Rock Paradise Valley	1	23.60	244.65
09/28/11	MDI Rock Rose Garden	1	21.91	266.56
09/28/11	MDI Rock Paradise Valley	1	23.88	290.44
09/28/11	MDI Rock Rose Garden	1	22.83	313.27
09/29/11	MDI Rock Rose Garden	1	23.16	336.43
09/29/11	MDI Rock Rose Garden	1	23.07	359.50
09/29/11	MDI Rock Rose Garden	1	25.64	385.14
09/29/11	MDI Rock Rose Garden	1	24.03	409.17
09/29/11	MDI Rock Rose Garden	1	24.90	434.07
09/29/11	MDI Rock Rose Garden	1	23.93	458.00
10/03/11	MDI Rock Glendale	1	23.81	481.81
10/03/11	C&R Trucking	4	90.28	572.09
10/03/11	C&R Trucking	5	115.21	687.30
10/03/11	C&R Trucking	5	117.16	804.46
10/03/11	C&R Trucking	5	97.26	901.72
10/04/11	MDI Rock Glendale	1	23.92	925.64
10/04/11	MDI Rock Glendale	1	23.86	949.50
10/04/11	MDI Rock Glendale	1	24.57	974.07
10/04/11	MDI Rock Glendale	1	23.88	997.95
10/04/11	MDI Rock Glendale	1	23.82	1021.77
10/04/11	MDI Rock Glendale	1	24.50	1046.27
10/04/11	MDI Rock Glendale	1	23.93	1070.20
10/04/11	C&R Trucking	5	113.34	1183.54
10/04/11	C&R Trucking	5	116.28	1299.82
10/04/11	C&R Trucking	5	90.52	1390.34
10/04/11	C&R Trucking	3	69.64	1459.98
10/05/11	C&R Trucking	5	118.82	1578.80
10/05/11	C&R Trucking	5	92.77	1671.57
10/05/11	C&R Trucking	4	96.85	1768.42
10/05/11	C&R Trucking	5	113.85	1882.27
10/05/11	MDI Rock Glendale	1	24.29	1906.56
10/05/11	MDI Rock Glendale	1	23.84	1930.40
10/05/11	MDI Rock Glendale	1	24.29	1954.69
10/05/11	MDI Rock Glendale	1	22.60	1977.29
10/05/11	MDI Rock Glendale	1	24.03	2001.32

Common Soil				
Date	Origin	Load Count	Weight (tons)	Total Import (tons)
10/05/11	MDI Rock Glendale	1	23.91	2025.23
10/05/11	MDI Rock Glendale	1	24.02	2049.25
10/05/11	MDI Rock Glendale	1	23.45	2072.70
10/05/11	MDI Rock Glendale	1	24.42	2097.12
10/05/11	MDI Rock Glendale	1	23.69	2120.81
10/05/11	MDI Rock Glendale	1	23.89	2144.70
10/06/11	C&R Trucking	5	119.17	2263.87
10/06/11	C&R Trucking	5	89.50	2353.37
10/06/11	C&R Trucking	5	114.39	2467.76
10/06/11	C&R Trucking	5	122.14	2589.90
10/06/11	MDI Rock Glendale	1	24.91	2614.81
10/06/11	MDI Rock Glendale	1	23.82	2638.63
10/06/11	MDI Rock Glendale	1	23.84	2662.47
10/06/11	MDI Rock Glendale	1	23.68	2686.15
10/06/11	MDI Rock Glendale	1	23.91	2710.06
10/06/11	MDI Rock Glendale	1	24.04	2734.10
10/06/11	MDI Rock Glendale	1	24.48	2758.58
10/06/11	MDI Rock Glendale	1	23.78	2782.36
10/06/11	MDI Rock Glendale	1	24.11	2806.47
10/06/11	MDI Rock Glendale	1	24.06	2830.53
10/06/11	MDI Rock Glendale	1	23.89	2854.42
10/06/11	MDI Rock Glendale	1	24.51	2878.93
10/06/11	MDI Rock Glendale	1	24.12	2903.05
10/06/11	MDI Rock Glendale	1	23.67	2926.72
10/06/11	MDI Rock Glendale	1	24.16	2950.88
10/10/11	C&R Trucking	5	117.58	3068.46
10/10/11	C&R Trucking	5	114.81	3183.27
10/10/11	C&R Trucking	5	122.27	3305.54
10/10/11	C&R Trucking	5	91.16	3396.70
10/10/11	C&R Trucking	1	12.48	3409.18
10/10/11	MDI Rock Glendale	1	24.23	3433.41
10/10/11	MDI Rock Glendale	1	24.00	3457.41
10/10/11	MDI Rock Glendale	1	24.21	3481.62
10/10/11	MDI Rock Glendale	1	22.75	3504.37
10/10/11	MDI Rock Glendale	1	23.12	3527.49
10/10/11	MDI Rock Glendale	1	25.10	3552.59
10/10/11	MDI Rock Glendale	1	24.41	3577.00
10/10/11	MDI Rock Glendale	1	24.12	3601.12
10/10/11	MDI Rock Glendale	1	24.14	3625.26
10/10/11	MDI Rock Glendale	1	22.95	3648.21
10/11/11	MDI Rock Glendale	1	24.06	3672.27
10/11/11	MDI Rock Glendale	1	24.00	3696.27
10/11/11	MDI Rock Glendale	1	23.72	3719.99
10/11/11	MDI Rock Glendale	1	24.26	3744.25
10/11/11	MDI Rock Glendale	1	23.99	3768.24
10/11/11	MDI Rock Glendale	1	25.00	3793.24

Common Soil				
Date	Origin	Load Count	Weight (tons)	Total Import (tons)
10/11/11	MDI Rock Glendale	1	24.32	3817.56
10/11/11	MDI Rock Glendale	1	23.52	3841.08
10/11/11	MDI Rock Glendale	1	23.96	3865.04
10/11/11	C&R Trucking	5	117.27	3982.31
10/11/11	C&R Trucking	5	92.84	4075.15
10/11/11	C&R Trucking	4	95.60	4170.75
10/11/11	C&R Trucking	3	42.23	4212.98
10/11/11	C&R Trucking	1	12.36	4225.34
10/11/11	C&R Trucking	5	122.59	4347.93
10/12/11	MDI Rock Glendale	1	22.69	4370.62
10/12/11	MDI Rock Glendale	1	24.03	4394.65
10/12/11	MDI Rock Glendale	1	26.60	4421.25
10/12/11	MDI Rock Glendale	1	23.98	4445.23
10/12/11	MDI Rock Glendale	1	24.24	4469.47
10/12/11	MDI Rock Glendale	1	23.94	4493.41
10/12/11	MDI Rock Glendale	1	24.62	4518.03
10/12/11	MDI Rock Glendale	1	23.95	4541.98
10/12/11	MDI Rock Glendale	1	23.62	4565.60
10/12/11	MDI Rock Glendale	1	26.13	4591.73
10/12/11	MDI Rock Glendale	1	23.71	4615.44
10/12/11	MDI Rock Glendale	1	24.07	4639.51
10/12/11	MDI Rock Glendale	1	23.79	4663.30
10/12/11	MDI Rock Glendale	1	23.67	4686.97
10/12/11	C&R Trucking	5	121.67	4808.64
10/12/11	C&R Trucking	5	118.21	4926.85
10/12/11	C&R Trucking	5	116.80	5043.65
10/12/11	C&R Trucking	3	38.33	5081.98
10/12/11	C&R Trucking	5	91.88	5173.86
10/13/11	MDI Rock Glendale	1	24.04	5197.90
10/13/11	MDI Rock Glendale	1	24.04	5221.94
10/13/11	MDI Rock Glendale	1	23.87	5245.81
10/13/11	MDI Rock Glendale	1	23.71	5269.52
10/13/11	MDI Rock Glendale	1	23.60	5293.12
10/13/11	MDI Rock Glendale	1	25.46	5318.58
10/13/11	MDI Rock Glendale	1	23.72	5342.30
10/13/11	MDI Rock Glendale	1	23.67	5365.97
10/13/11	MDI Rock Glendale	1	24.04	5390.01
10/13/11	C&R Trucking	5	120.61	5510.62
10/13/11	C&R Trucking	5	92.53	5603.15
10/13/11	C&R Trucking	5	116.00	5719.15
10/13/11	C&R Trucking	3	37.74	5756.89
10/14/11	MDI Rock Glendale	1	23.88	5780.77
10/14/11	MDI Rock Glendale	1	23.78	5804.55
10/14/11	MDI Rock Glendale	1	23.52	5828.07
10/14/11	MDI Rock Glendale	1	24.03	5852.10
10/14/11	MDI Rock Glendale	1	24.28	5876.38

Common Soil				
Date	Origin	Load Count	Weight (tons)	Total Import (tons)
10/14/11	MDI Rock Glendale	1	23.86	5900.24
10/14/11	MDI Rock Glendale	1	24.02	5924.26
10/14/11	MDI Rock Glendale	1	24.31	5948.57
10/14/11	C&R Trucking	5	114.37	6062.94
10/14/11	C&R Trucking	5	123.15	6186.09
10/14/11	C&R Trucking	3	41.03	6227.12
10/14/11	C&R Trucking	4	71.87	6298.99
10/14/11	C&R Trucking	5	116.82	6415.81
10/24/11	MDI Rock Glendale	1	23.44	6439.25
10/24/11	MDI Rock Glendale	1	24.07	6463.32
10/24/11	MDI Rock Glendale	1	23.70	6487.02
10/24/11	MDI Rock Glendale	1	24.07	6511.09
10/24/11	MDI Rock Glendale	1	12.45	6523.54
10/24/11	MDI Rock Glendale	1	22.82	6546.36
10/24/11	C&R Trucking	5	115.85	6662.21
10/24/11	C&R Trucking	5	119.35	6781.56
10/24/11	C&R Trucking	5	121.95	6903.51
10/24/11	C&R Trucking	5	93.54	6997.05
10/24/11	C&R Trucking	3	42.82	7039.87
10/25/11	C&R Trucking	2	35.92	7075.79
10/25/11	C&R Trucking	2	48.22	7124.01
10/25/11	C&R Trucking	2	45.62	7169.63

Topsoil			
Date Delivered	Origin	Weight (tons)	Total Import (tons)
9/22/2011	MDI Rock	23.79	23.79
9/22/2011	MDI Rock	24.23	48.02
9/23/2011	MDI Rock	23.39	71.41

Sampling							
Supplier	Fill Type	Material Origin	Sample ID	Date Sampled	Date Results Reported	Result (As)	Result (Pb)
MDI Phoenix	Topsoil	Glendale	MDI-Glendale-Topsoil(A+B)	9/23/2011	9/27/2011	11 & 9	5.8 & 6.4
	Topsoil	Paradise Valley	MDI-MG-Topsoil			<5.0	8.4

MDI Glendale	Common	Glendale	MDI-GD- Common-001	9/28/2011	9/30/2011	8.9	<5.0
	Common	Glendale	MDI-GD- Common-002			8.3	5.7
MDI Phoenix	Common	Rose Garden	MDI-RG- Common	9/23/2011	9/27/2011	10	9.1
Arrowhead	Common	Arrowhead	Arrowhead- Common-001	9/29/2011	9/30/2011	14	8.8
	Common	Arrowhead	Arrowhead- Common-002			13	8.8
	Common	Arrowhead	Arrowhead- Common-003	10/4/2011	10/5/2011	15	9.9
	Common	Arrowhead	Arrowhead- Common-004			15	11
	Common	Arrowhead	Arrowhead- Common-005			16	12
	Common	Arrowhead	Arrowhead- Common-006			14	12
	Common	Arrowhead	Arrowhead- Common-007	10/13/11	10/20/11	12	7.8
	Common	Arrowhead	Arrowhead- Common-008			12	8.0
	Common	Arrowhead	Arrowhead- Common-009			15	9.6
	Common	Arrowhead	Arrowhead- Common-010			14	8.9

The addresses for the facilities providing the borrow material are:

Material Delivery, Inc. (MDI)
 10233 W. Northern Avenue
 Glendale, AZ 85355

MDI
 2815 East Rose Garden Lane
 Phoenix, AZ 85050

MDI
 8524 North Morning Glory Road
 Paradise Valley, AZ 85253

C&R Arrowhead
 1405 Road 6 North
 Chino Valley, AZ 86323

ECOLOGY AND ENVIRONMENT, INC.
Superfund Technical Assessment and Response Team
Iron King Mine – Humboldt Smelter Removal
Dewey-Humboldt, Yavapai County, Arizona

E&E Project. No.: 002693.2155.01RF

TDD No: TO2-09-11-08-0005
Contract No. EP-S5-08-01

PHOTO 1

Date: 10/6/11

Direction: Northeast

Photographer: M. Schwennesen,
START

Description: Backfill soil being placed over snow fence at two-foot depth on the southeast side of OFS-133/northwest side of OFS-119.



PHOTO 2

Date: 11/4/11

Direction: Northeast

Photographer:
M. Schwennesen, START

Description: OFS-133 after site restoration that included a new fence.

ECOLOGY AND ENVIRONMENT, INC.
Superfund Technical Assessment and Response Team
Iron King Mine – Humboldt Smelter Removal
Dewey-Humboldt, Yavapai County, Arizona

E&E Project. No.: 002693.2155.01RF

TDD No: TO2-09-11-08-0005
Contract No. EP-S5-08-01



PHOTO 3

Date: 10/3/11

Direction: Southeast

Photographer:

M. Schwennesen, START

Description: Pre-removal back yard of OFS-118.

PHOTO 4

Date: 10/7/11

Direction: Northwest

Photographer:

M. Schwennesen, START

Description: Placement of clean soil over snow fence in progress in back yard of OFS-118.



PHOTO 5

Date: 10/14/11

Direction: Southeast

Photographer:

M. Schwennesen, START

Description: Back yard of OFS-118 after completion of site restoration.

ECOLOGY AND ENVIRONMENT, INC.
Superfund Technical Assessment and Response Team
Iron King Mine – Humboldt Smelter Removal
Dewey-Humboldt, Yavapai County, Arizona

E&E Project. No.: 002693.2155.01RF

TDD No: TO2-09-11-08-0005
Contract No. EP-S5-08-01



PHOTO 6

Date: 9/24/11

Direction: Southeast

Photographer: M. Schwennesen,
START

Description: Foreground excavator removes contaminated soil from the backyard of OFS-111 while a second excavator removes contaminated soil at OFS-260. Humboldt Smelter is visible in the background.

ECOLOGY AND ENVIRONMENT, INC.
Superfund Technical Assessment and Response Team
Iron King Mine – Humboldt Smelter Removal
Dewey-Humboldt, Yavapai County, Arizona

E&E Project. No.: 002693.2155.01RF

TDD No: TO2-09-11-08-0005
Contract No. EP-S5-08-01



PHOTO 7

Date: 10/27/11

Direction: North

Photographer:

M. Schwennesen, START

Description: The Small Tailings Pile in background (to the left of the bulldozer), with START's southern air station in the foreground.



PHOTO 8

Date: 10/29/11

Direction: West

Photographer:

M. Schwennesen, START

Description: Excavator removing gray sludge material from the north end of the Small Tailings Pile.

ECOLOGY AND ENVIRONMENT, INC.
Superfund Technical Assessment and Response Team
Iron King Mine – Humboldt Smelter Removal
Dewey-Humboldt, Yavapai County, Arizona

E&E Project. No.: 002693.2155.01RF

TDD No: TO2-09-11-08-0005
Contract No. EP-S5-08-01



PHOTO 9

Date: 11/9/11

Direction: Northeast

Photographer:

M. Schwennesen, START

Description: Most of the Small Tailings Pile has been removed. The excavator is working in the northwest portion of the pile, near the spill point leading from Iron King Mine property.



PHOTO 10

Date: 11/14/11

Direction: North

Photographer:

M. Schwennesen, START

Description: The Small Tailings Pile has been removed and the area has been re-contoured. Construction of a 400-foot diversion channel made with filter fabric and riprap is in progress.



Lockheed Martin Information Systems & Global Solutions - Civil
Environmental Services SERAS
2890 Woodbridge Avenue, Building 209 Annex
Edison, NJ 08837-3679
Telephone 732-321-4200, Facsimile 732-494-4021

DATE: March 27, 2012

TO: Terrence Johnson, Ph.D., U.S. EPA/ERT Work Assignment Manager

THROUGH: Dennis Miller, SERAS Program Manager *DM*
Rick Leuser, SERAS Deputy Program Manager *RL*

FROM: David Aloysius, PG/CPG, SERAS Task Leader *DA*

SUBJECT: **SITE RESTORATION DESIGN AND IMPLEMENTATION
IRON KING MINE SITE HYDROLOGIC RESTORATION
DEWEY-HUMBOLDT, ARIZONA
WORK ASSIGNMENT - SERAS 0-146: TECHNICAL MEMORANDUM**

INTRODUCTION

This technical memorandum presents the results of design-related calculations, proposed remedies, and on-site observations concerning area-specific hydrologic restoration at the Iron King Mine Site. The work was performed by the Lockheed Martin Task Leader (TL) from the Scientific, Engineering, Response and Analytical Services (SERAS) contract in consultation with the Environmental Protection Agency (EPA) Environmental Response Team (ERT) Work Assignment Manager (WAM) and the EPA Region 9 On-Scene Coordinator (OSC). The SERAS TL was present on site from November 10 through November 15, 2011 to observe all on-site construction activities critical to the hydrologic restoration effort. Site restoration was completed by an EPA Region 9 contractor.

SITE BACKGROUND

The Iron King Mine Site is located in the Town of Dewey-Humboldt, Arizona (AZ). The site, which occupies approximately 153 acres, was periodically operated from 1906 to 1969 for extraction of gold, silver, copper, lead and zinc. The Iron King Mine is bordered by Chaparral Gulch to the north (Figure 1), Galena Gulch to the south, State Highway 69 to the east, and undeveloped land to the west.

There are two tailings piles at the site: the Large Tailings Pile (LTP) and the Small Tailings Pile (STP). The LTP, located just west of Highway 69, covers over 55 acres, is over 100 feet in height and contains over six million cubic yards of mine tailings. The STP is located approximately 600 feet north of the LTP and was found to contain approximately 21,500 cubic yards of tailings (based on field delineation and excavation in November 2011). Chaparral Gulch borders the STP along the northern and eastern sides and is impacted by both runoff and sediment transport from the pile. This pile was an accumulation of

tailings materials that resulted from surface water-related sediment transport over many decades, which began as early as 1940.

The EPA Region 9 Removal Program proposed to excavate and move materials from the STP, and subsequently consolidate the materials immediately adjacent to the LTP, within a temporary storage pile (TSP). Based on the physical characteristics of the site and the general nature of the proposed work, EPA Region 9 requested assistance from the ERT to provide technical support for area restoration of the STP and adjoining areas. This effort included a combination of hydrologic, open channel, and slope stabilization designs for minimizing runoff, erosion, and sediment transport. In addition, interim measures were also required for stabilizing the tailings within the TSP and minimizing surface erosion.

Site Geology

The Iron King mine is approximately located in the geographical center of the Humboldt region. The underlying bedrock is Precambrian in age (Creasey, 1952). Late Cenozoic unconsolidated river wash and valley fill, with some interbedded basalt, locally mantle the Precambrian rocks, especially in the north-central part of the region. The Precambrian rocks consist of two metamorphosed volcanic formations and intrusive rocks that range in composition from quartz porphyry to gabbro. The volcanic formations originally were flows, volcanic breccias, and tuffaceous sedimentary rocks. Dynamo-thermal metamorphism of these rocks formed textures, structures, and mineral assemblages characteristic of low-grade metamorphic rocks; however, sufficient relict textures and structures remain to permit delineation of formations. The Precambrian rocks strike north to northwest and steeply dip in a predominant westward direction.

METHODS

Site Assessment and Proposed Plans

An initial visit to the Iron King Mine Site occurred on July 18, 2011. Parties in attendance included the EPA/ERT WAM and the Lockheed Martin SERAS TL. The purpose of this visit was to visually evaluate and assess the specific areas under investigation. The SERAS TL returned to the site for a one day visit on November 1, 2011 to meet with the EPA Region 9 OSC and the Region 9 contractor to discuss specific details regarding the hydrologic restoration effort.

Proposed final plans for area-specific restoration included the following:

- Subsequent to moving the STP and re-grading the area, a new riprap-lined diversion channel would be constructed, extending from the base of a nickpoint (an abrupt elevation change in the existing channel) to a tributary channel that leads into Chaparral Gulch: a total distance of approximately 400 feet (Figure 1). It was believed that the alignment of the new channel would be a more direct course to Chaparral Gulch (compared to the pre-restoration site drainage channels) and therefore, would be capable of diverting storm water runoff more efficiently and effectively across the site.
- Straw-bales had originally lined the face of the nickpoint. The bales would be removed, the exposed area would be covered with non-woven filter fabric, and then coarse riprap, up to 24-inches in size, would strategically be placed throughout the area to ensure future stability.
- Original drainage channels (gullies) that had originally surrounded the STP (Figure 1) would be partially backfilled with riprap (in key areas) to minimize future erosion, gully formation, and mass wasting of adjoining slopes. In areas where remnant gully walls remained very steep to

vertical (i.e., after site re-grading), coarse riprap would be used to buttress the toes of the embankments.

- Straw wattles would be placed along key slopes throughout the restored STP area in order to intercept surface water runoff and minimize soil erosion and rilling.
- Prior to construction of the TSP, a geosynthetic-reinforced foundation pad would be placed over the ground surface for base reinforcement and subgrade stabilization.

Hydrologic Calculations

Based on discussions with the EPA/ERT WAM, a 50-year return period storm for the local area was used for the design.

Drainage Area Evaluation: A watershed analysis was initially performed using geographic information system (GIS) software to calculate the total drainage area upstream of the new channel discharge point.

Peak discharge estimates: Computer software was used to determine a peak discharge resulting from a 50-year return period storm (NRCS, 2009). Key data that were gathered and incorporated into the analysis included the following:

- Hydrologic Soil Group: Site-specific information obtained from the Natural Resources Conservation Service (NRCS). The soils at the site are classified as Group B. Group B soils have moderate infiltration rates when thoroughly wetted and consist chiefly of soils that are moderately deep to deep, moderately well drained to well drained, and have moderately fine to moderately coarse textures. These soils have a moderate rate of water transmission (0.15 to 0.30 inches per hour).
- Runoff Curve Number (RCN): A numerical representation of the cover type, which directly affects runoff. The RCN for a given soil-cover type is not constant but varies from storm to storm. The index of runoff potential for a given storm is the antecedent runoff condition (ARC). The ARC is an attempt to account for the variation in the RCN at the site from storm to storm. RCNs used for design purposes are typically based on an average ARC. The site-specific RCN was classified as arid rangeland, desert shrub, with poor coverage.
- Watershed Length: Length in feet along the flow path from the hydraulically most distant point within the watershed to the point of interest (i.e., the intersection of the new channel with Chaparral Gulch).
- Watershed Slope: Average slope in percent of the all the contributing land within the watershed boundary (not simply the slope of the main channel or steepest watercourse). This was determined mathematically using GIS software by summing all the individual contour lengths within the watershed, multiplying the total contour length by the contour interval, dividing the product by the watershed area, and then multiplying by 100.
- Time of Concentration: A calculated parameter that relates to the time in hours for runoff to flow from the most hydraulically remote point within the watershed to the point of interest.
- 24-hour Rainfall: The amount of precipitation in a 24-hour period for the corresponding frequency (for this study, a 50-year return period storm). Precipitation data for Dewey, AZ were

obtained from the National Oceanic and Atmospheric Administration's (NOAA) National Weather Service (NWS) Hydrometeorological Design Studies Center (Point Precipitation Frequency Estimates, NOAA Atlas 14). Station location: Latitude: 34.5050; Longitude: -112.1422.

- Rainfall Type: Refers to a set of synthetic rainfall distributions having "nested" rainfall intensities. The set maximizes the rainfall intensities by including selected short-duration intensities with those needed for longer duration. The Type II storm distribution for this region is typical of the more intense storms that occur over much of the United States.

Hydraulic Calculations

A user-developed spreadsheet program was used to determine critical hydraulic parameters for the new channel, which included channel geometry, maximum flow depth, and resulting shear stresses. The program is based on the Manning's equation (McCuen, 1998).

The Manning's roughness coefficient (n), a number that describes the relative roughness of a surface, is an important parameter that is included in the analysis. As this number increases so does the surface roughness. Reduced velocities associated with increased roughness will decrease the amount of erosion. Based on site conditions, an estimated value of 0.025 was used in the analysis. Note, for „natural“ stream channels, values can exceed 0.10.

Riprap Size and Thickness Design

A number of riprap design methods were investigated for the new channel in order to meet the overall goals of the project (Blodgett and McConaughy, 1986; FHWA, 2001). Manual calculations were subsequently compared to methods developed by the Army Corps of Engineers (Maynard *et.al*, 1998).

RESULTS

Derived Hydrologic/Hydraulic Data and Riprap Specifications

The derived data are summarized in Table 1. Hydraulic data for the new channel are based on a trapezoidal design with an average bottom width of 3 feet, side slopes of 3: 1 (horizontal: vertical), an average depth of 3 feet, and an average top width of 21 feet.

The D-size for the riprap relates to the rock diameter (measured as „equivalent spherical diameter“). For example, D-15 relates to a rock size diameter at which 85 percent of the other rocks are larger. D-100 is the maximum rock size and D-50 is the „median“ rock size. A minimum riprap thickness of 24-inches was recommended, based on an assumed rock density or specific gravity of 165 pounds per cubic foot (pcf).

The final design details for the new diversion channel are presented in Figure 2.

Field Construction Design Specifications

Diversion Channel Depth and Grade: In most areas, the average channel depth would be at least 1-foot greater than the riprap thickness. During construction, the channel gradient or slope would be periodically measured to ensure proper grade control (on average, 1-foot drop over 15.4 feet). This would be accomplished using standard surveying, laser-leveling, or line-leveling field methods.

Subgrade Preparation: Prior to filter fabric installation, any additional grade-control fill that could be required in the subgrade would be compacted to a density approximating that of the surrounding undisturbed materials, or any obvious depressions would be overfilled with small riprap. Small brush, trees, stumps, and other objectionable materials would be removed. The subgrade would be cut sufficiently deep so that the finished grade of the riprap along the side slopes would roughly equal the surface elevation of the surrounding areas. The channel would be excavated sufficiently to allow placement of the riprap in a manner such that the finished inside channel dimensions and riprap grade would meet the design specifications.

Non-Woven Filter Fabric: Filter fabric sheeting would be placed directly on the prepared foundation surfaces with a 12-inch minimum overlap. The upper and lower ends of the fabric would be buried to a minimum of 4-inches below the ground surface. Precautions would be taken not to damage the fabric by dropping the riprap. If damage occurred, the riprap would be removed and the sheet would be repaired by adding another layer of filter fabric with a minimum overlap of 12-inches around the damaged area.

Riprap Placement: Placement of the riprap would follow immediately after placement of the filter fabric. Riprap would be placed so that it formed a dense, well-graded mass of rock with minimal voids. The desired distribution of rocks throughout the mass would be obtained by selective loading at a local quarry and controlled dumping during final placement. The riprap would be placed to its full thickness in one operation. The finished channel slopes and channel bottom would be free of pockets (of both small rocks and clusters of large rocks). The finished grade of the riprap would blend in with the surrounding areas.

Downstream Stilling Basin (Energy Dissipator): The downstream end of the diversion channel (before it intersects a small, existing tributary that leads into Chaparral Gulch), would be excavated to a maximum width of approximately 30 feet over a 25-foot horizontal distance, forming an enlarged basin. The minimum depth of the basin would be approximately 1.7 feet (20-inches). The „bottom width“ of the basin would be gradually decreased in both upstream and downstream directions, from approximately 30 feet to 3 feet (to blend into the upstream diversion channel and downstream tributary), over horizontal distances of 15 feet, forming an elongated octagon in plan-view. Additionally, the depth of the diversion channel would be gradually decreased in a downstream direction, from 3 feet to no less than 1.7 feet. The installed thickness of the riprap within the stilling basin, subsequent to filter fabric placement, would be equal to the diameter of the largest rock size or not less than 1-foot. The stilling basin would be necessary in order to dissipate or slow downstream water flow before entering a natural watercourse that leads into Chaparral Gulch Arroyo.

ON-SITE CONSTRUCTION AND RESTORATION

The SERAS TL was present on site from November 10 through November 15, 2011 to observe all on-site construction activities critical to the hydrologic restoration effort. Notes, observations, and measurements recorded during the on-site construction-restoration phase are provided below:

Diversion Channel Construction Materials

- Base filter fabric: PermeaTex 4060 nonwoven geotextile (Northwest Linings & Geotextile Products, Inc.)
- Coarse riprap
 - Source: local quarry
 - Rock type: gabbro
 - Size gradation (approximate): 8- to 24-inches (larger sizes more abundant)
 - Specific gravity: 177 pounds per cubic foot (pcf)

- Total tonnage used: 360
- Graded riprap
 - Source: same as above
 - Rock type: gabbro
 - Size gradation (approximate): 4- to 20-inches
 - Specific gravity: 177 pcf
 - Total tonnage used: 1,160

Construction Activities

- Removed materials from the Small Tailings Pile (STP). In some areas, the depth of excavation was up to 15 feet. Excavated materials were transported to the temporary storage pile (TSP) area. The STP footprint and surrounding areas were graded and contoured using soil material that was primarily acquired from adjacent on-site areas.
- Constructed a riprap-lined diversion channel, approximately 400 feet in length, which included a natural spillway (nickpoint) at the upstream end and a stilling basin (energy dissipator) at the downstream end (refer to Figure 1). Excavators were used to construct the channel and stilling basin and partially re-surface the nickpoint area.
 - After sections of earthwork were completed, nonwoven filter fabric was neatly laid out within the finished areas (i.e., nickpoint, channel, and stilling basin). The filter fabric provides a stable base for subsequent placement of riprap and also minimizes channeling of water beneath the riprap (which prevents undermining).
 - The upstream nickpoint was approximately 65 feet in width (arch-shaped), having a 3-foot vertical drop and a 5-degree slope along a 30-foot downstream section.
 - The diversion channel was approximately 3 feet deep with 3:1 slopes. The bottom width was approximately 3 feet and the top width, at ground surface, was approximately 21 feet (refer to Figure 2). Field measurements were periodically acquired using a Brunton™ pocket transit and laser level to ensure adherence to the design specifications.
 - The stilling basin was approximately 55 feet in length with 4: 1 slopes. In the center of the basin, the bottom width was approximately 30 feet, over a 25-foot distance, which tapered down to 3 feet in both upstream and downstream directions (forming an elongated octagonal shape in plane-view). The depth of the basin varied due to surface topography; however, the minimum depth was no less than 1.7 feet (20-inches).
 - The coarsest riprap was placed within the nickpoint area and along the upstream section of the channel to maximize the reduction of flow energy during peak runoff events. Within the nickpoint area, the riprap thickness was approximately 3 feet (placed to the top crest of the nickpoint). The average thickness of riprap along the channel bottom and side slopes was approximately 2 feet. Within the stilling basin, the average riprap thickness decreased to approximately 16-inches.

- Placed riprap (approximately 16-inches in thickness) along a newly-constructed graded outfall that intersects the southern gully (refer to Figure 1). The length and width of riprap treatment was approximately 26 feet by 25 feet, respectively. Riprap (up to 3 feet in thickness) was additionally placed along a 73-foot section of the southern gully, upstream of the outfall.
- Placed riprap along the toe of a vertical soil embankment (a remnant of the former gully), over a horizontal distance of approximately 70 feet, to provide slope stabilization. The height of the riprap ranged from 3.5 to 4 feet and the bottom width averaged around 8 feet. In cross-sectional view, the riprap formed a triangular buttress along the embankment toe, being widest at ground surface. The vertical height of the embankment ranged from approximately 7 to 12 feet.
- Installed five small riprap check dams along remaining gully sections to slow the movement of stormwater runoff during peak runoff events.
- Installed 675 feet of 8-inch diameter straw wattles along final graded slopes in key areas to minimize soil erosion.

NOTE: The original riprap design was based on an assumed rock density of 165 pcf. Considering that the actual rock density was approximately 177 pcf, it is expected that the final design should exceed the 50-year design storm event.

TSP Design Summary

- Geosynthetic base pad: PermeaTex HS0404 high-strength woven geotextile
- Base pad dimensions (approximate): 220 feet x 165 feet
- Base dimensions of tailings (approximate): 265 feet x 195 feet (tailings overlap base pad)
- Vertical height (approximate): 5.5 feet to less than or equal to 8 feet (height varied)
- Side slopes (approximate): 3:1
- Surface stabilizer: sprayed with an eco-safe, biodegradable, liquid co-polymer (Gorilla-Snot®) to stabilize the tailings and minimize future erosion.

TSP Materials Summary

- Tailings: placed in the TSP over geosynthetic pad: 19,058 cubic yards (cy)
- Tailings (with high moisture content): segregated and placed next to the TSP: 1,066 cy
- Tailings/sludge material: segregated and placed next to the TSP: 1,378 cy
- TOTAL volume of materials removed from the STP: 21,502 cy

Photo-Documentation

A number of photos obtained during the on-site construction activities are presented in Appendix A.

REFERENCES

Blodgett, J.C. and C.E. McConaughy, 1986. Rock Riprap Design for Protection of Stream Channels near Highway Structures, Volume 2: Evaluation of Riprap Design Procedures. U.S. Geological Survey Water Resources Investigation Report 86-4128. Prepared in cooperation with the Federal Highway Administration.

Creasey, S.C., 1952. Geology of the Iron King Mine, Yavapai County, Arizona. Economic Geology, Vol. 47, No. 1, pp. 24-56. January 1952.

Federal Highway Administration (FHWA), 2001. Urban Drainage Design Manual. Hydrologic Engineering Circular No. 22, 2nd edition. Publication No. FHWA-NHI-01-021. U.S. Department of Transportation. Prepared in cooperation with the National Highway Institute. August 2001.

McCuen, R.H., 1998. Hydrologic Analysis and Design. Prentice Hall. 2nd edition.

Natural Resources Conservation Service (NRCS), 2009. EFH2 Computer Program: Estimating Runoff and Peak Discharge. U.S. Department of Agriculture. August 2009.

National Oceanic and Atmospheric Administration (NOAA). Point Precipitation Frequency Estimates, NOAA Atlas 14. National Weather Service (NWS), Hydrometeorological Design Studies Center.

Maynard, S.T., M.T. Hebler, and S.F. Knight, 1998. User's Manual for CHANLPRO, PC Program for Channel Protection Design. U.S. Army Corps of Engineers, Waterways Experiment Station, Coastal & Hydraulics Laboratory, Vicksburg, Mississippi. Technical Report CHL-98-20. July 1998.

TABLE

TABLE 1
Hydrologic, Hydraulic and Riprap Size Data
Iron King Mine Site Hydrologic Restoration
Dewey-Humboldt, Arizona

Watershed-Hydrologic Data

Drainage Area	48.1 acres
Hydrologic Soil Group	B
Runoff Curve Number	77
Watershed Length	2,710 feet
Watershed Slope	15.0 %
Time of Concentration	0.33 hours
Rainfall Distribution	Type II
24-hour rainfall (50-year storm)	3.76 inches
Peak Discharge	75 cubic feet per second (cfs)
Runoff	1.63 inches

Diversion Channel Hydraulic Data

Channel Length	400 feet (+/-)
Channel Slope	0.065 ft/ft (~ 3.7 degrees from horizontal) <u>or</u> a 1-foot drop over 15.4 feet of horizontal distance
Manning's n (estimated)	0.025
Channel Shape	trapezoidal
Bottom Width (avg.)	3.0 feet
Channel Sides	3: 1 slopes (horizontal: vertical)
Channel Depth	3.0 feet (recommended average)
Channel Top Width	21 feet
Max. Flow Depth	1.05 feet
Max. Flow Width	9.30 feet
Min. Freeboard	0.92 feet
Max. Flow Velocity	11.63 feet per second (fps)
Max. Shear Stress (bottom)	2.64 pounds per square foot (psf)
Max. Shear Stress (sides)	2.04 psf

Channel Riprap Specifications

D-100 Rock Size	19-inches avg. (range 17- to 20-inches)*
D-50	13-inches avg. (range 10- to 16-inches)*
D-15	9-inches avg. (range 6- to 11-inches)*
Min. Riprap Thickness	24-inches*

* Based on a rock density of 165 pcf

FIGURES

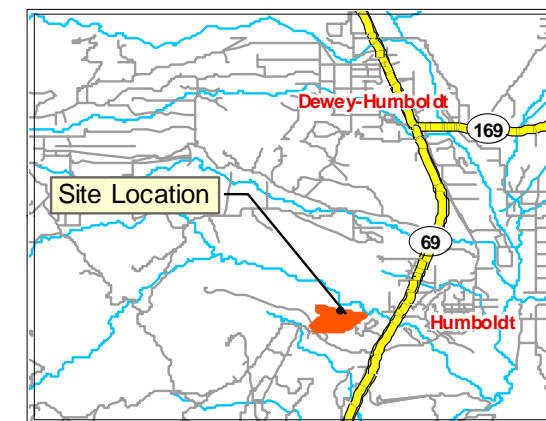
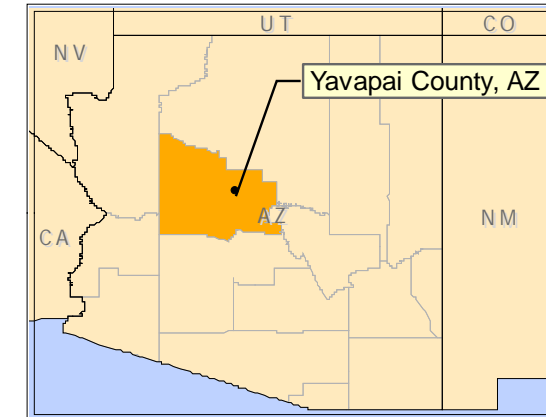
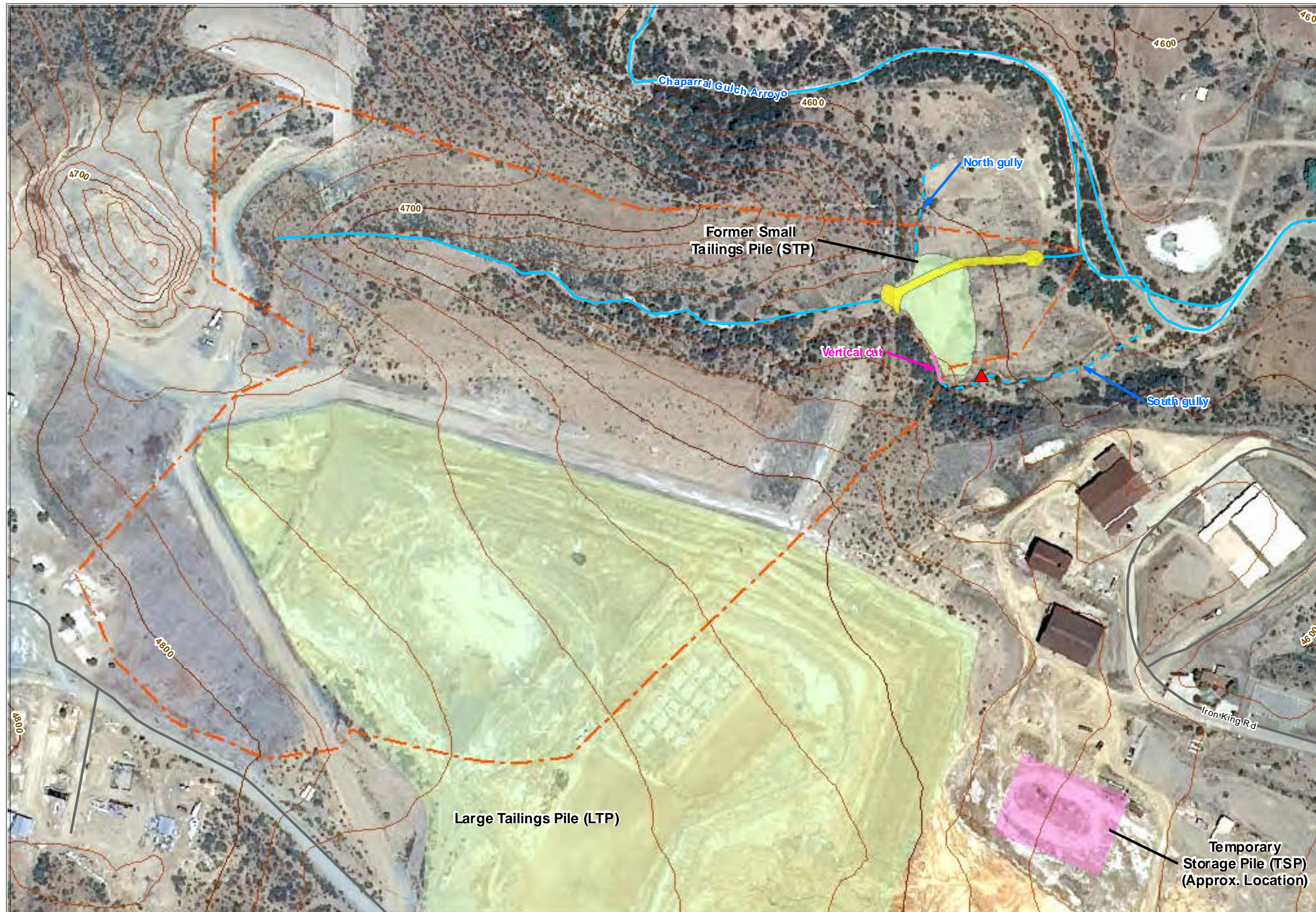

Legend

- ▲ Riprap Outfall
- Drainage Channel
- - - Gully Drainage
- Index Contour
(C.I. = 100 feet)
- - - Intermediate Contour
(C.I. = 20 feet)
- Riprap-Lined Diversion Channel
(Channel Length = 402.4 feet)
- - - Sub-Watershed
(48.08 Acres)

Base map created using NAIIP orthoimagery from USGS, contour and watershed derived from DEM data from USGS.
Diversion channel data from GPS survey 2011.

Map Creation Date: 01 December 2011

Coordinate system: Arizona State Plane
FIPS: 0202
Datum: NAD83
Units: Feet

Data: g:\arcviewprojects\SERAS01\00-146
MXD file: g:\arcviewprojects\SERAS01\SER00146_IronKingMineSite\146_TM2011_Investigation_Area_FinalDesign_f1

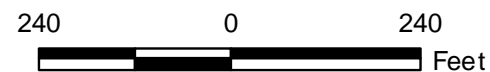

U.S EPA Environmental Response Team
Scientific Engineering Response and Analytical Services
EP-W-09-031
W.A. # 0-146

Figure 1
Investigation Area: Final Design
Iron King Mine Site Hydrologic Restoration
Dewey-Humboldt, Arizona

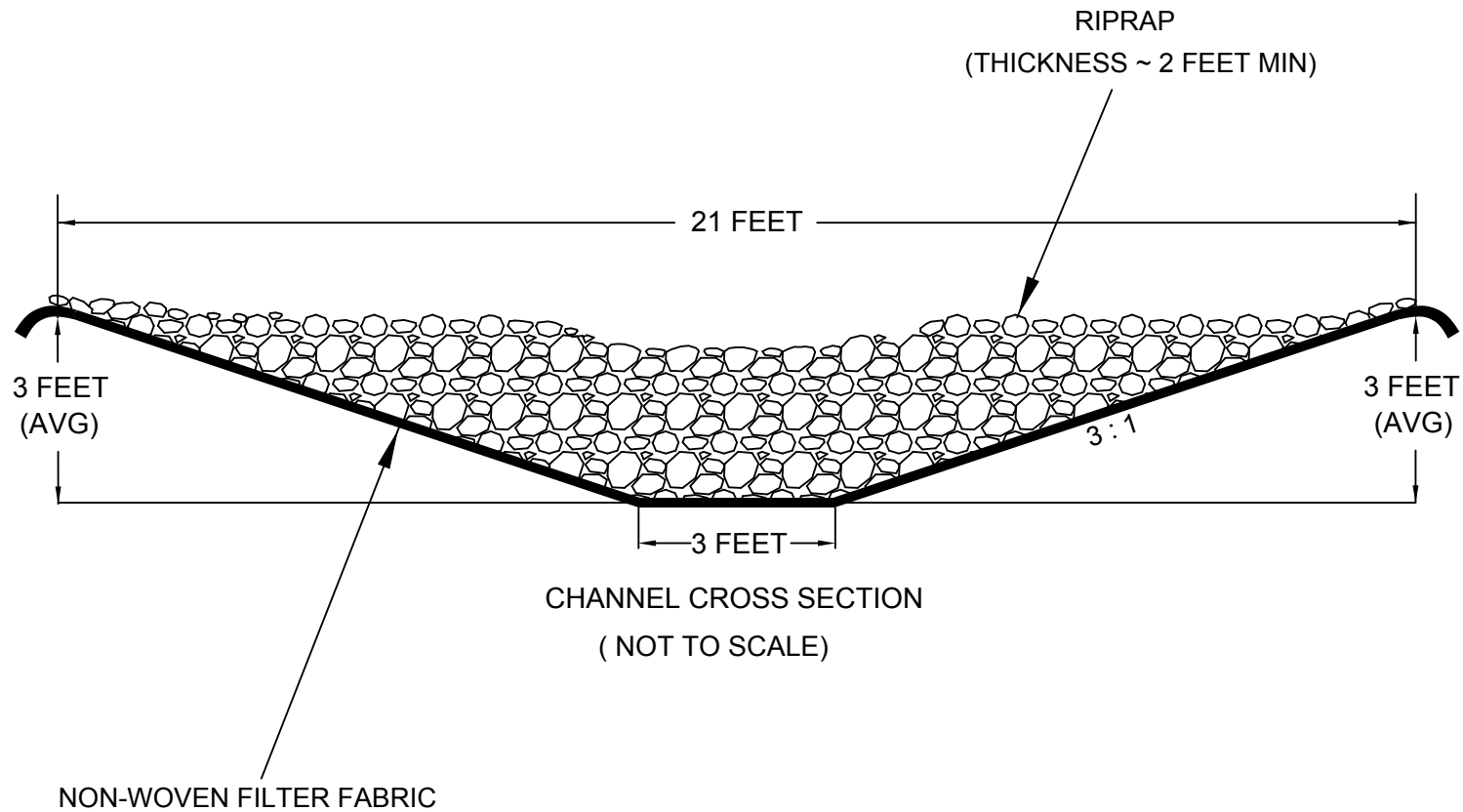

U.S. EPA Environmental Response Team
 Scientific Engineering Response and Analytical Services
 EP-W-09-031
 W.A.# 0 - 146

Figure 2
 Diversion Channel Design
 Iron King Mine Site Hydrologic Restoration
 Dewey-Humboldt, Arizona

APPENDIX A

Photo Documentation
Iron King Mine Site Hydrologic Restoration
Dewey-Humboldt, Arizona
Technical Memorandum
March 2012



Nickpoint (NP) area prior to final slope adjustment and grading



NP area prior to final slope adjustment and grading



South gully prior to final grading



NP area – beginning of riprap treatment



Completed NP area, looking upstream



Diversion channel construction, downstream of NP area



Excavated centerline of diversion channel, downstream of NP area



Diversion channel excavation and shaping



Installation of straw wattles along slopes



Completed channel section, looking upstream



Construction of downstream stilling basin



South gully – after grading and riprap treatment



Vertical embankment with final riprap buttress



Final graded slopes with straw wattles



Rock check dam along downstream section of the south gully



Final riprap-lined outfall leading into the south gully



Completed diversion channel, looking downstream from NP area



Temporary storage pile (tailings repository)